



PVC-U 塑膠管·接頭

Pipes | Fittings



南亞塑膠工業股份有限公司
NAN YA PLASTICS CORPORATION



特性 用途

1. PVC-U管 · 接頭特性與用途 3

2. PVC-U管 · 接頭之物理及 化學性質 5

管材 規格

3. PVC-U管規格

- 15 (一) 一般用PVC-U管
 - VU(A管) 一般薄管
 - VP(B管) 一般厚管
 - 活套VP(B管) 一般用管
- 18 (二) 自來水用管
 - W管
 - 活套管(自來水用)
- 20 (三) PVC-U電線導管
 - E管
 - ES-1管
- 21 (四) 耐衝擊PVC-U管
- 22 (五) 長型活套管(A型)
- 23 (六) 可撓性活套管(B型)
- 23 (七) 管筏用PVC-U管
- 24 (八) 鑿井用管
- 25 (九) TS放口管(單放)

施工 方法

4. PVC-U管之施工法

- 26 (一) PVC-U管施工方法
- 30 (二) PVC-U管施工應注意事項

接頭 規格

5. 自來水用接頭規格

- 36 · 45° WL型接頭
- 36 · 90° WL型接頭
- 37 · WT型同徑接頭
- 37 · WT型異徑接頭
- 38 · WS型同徑接頭
- 38 · WS型異徑接頭

接頭 規格

5. 自來水用接頭規格

- 39 · 龍L入銅接頭
- 39 · 龍T入銅接頭
- 40 · 龍S入銅接頭
- 40 · 止閘接頭(塑膠牙)
- 41 · 由令
- 41 · 塞頭
- 42 · 伸縮接頭

6. 灰色一般用接頭規格(厚、薄)

- 43 · 45° L型接頭
- 43 · 90° L型接頭
- 44 · 45° L型單放口接頭
- 44 · 90° L型單放口接頭
- 44 · 90° L型異徑接頭
- 44 · T型同徑接頭
- 45 · T型異徑接頭
- 46 · 排氣T型排水接頭
- 46 · S型同徑接頭
- 47 · S型異徑接頭
- 48 · 順T型同徑接頭
- 48 · 順T型異徑接頭
- 49 · Y型同徑接頭
- 49 · Y型異徑接頭
- 49 · Y型接頭單插口
- 50 · 組合式穿樑接頭
- 50 · 樓板接頭
- 50 · 外壁偏心接頭
- 51 · 龍L接頭(塑膠牙)
- 51 · 龍T接頭(塑膠牙)
- 51 · 龍S接頭(塑膠牙)
- 52 · 止閘接頭(塑膠牙)
- 52 · 塞頭
- 52 · 清除孔接頭
- 53 · 法蘭接頭
- 53 · 漏斗
- 53 · 止水板接頭
- 53 · 雙層止水板接頭
- 53 · 通氣口接頭

接頭 規格

7. HI耐衝擊PVC-U管接頭規格

- 54 · 45° L型接頭
- 54 · 90° L型接頭
- 55 · T型同徑接頭
- 55 · T型異徑接頭
- 56 · S型同徑接頭
- 56 · S型異徑接頭
- 57 · 塞頭
- 57 · 法蘭接頭
- 57 · 由令
- 58 · 止閥接頭(塑膠牙)
- 58 · 龍L入銅接頭
- 58 · 龍L接頭(塑膠牙)
- 59 · 龍T入銅接頭
- 59 · 龍T接頭(塑膠牙)
- 60 · 龍S入銅接頭
- 60 · 龍S接頭(塑膠牙)
- 61 · 伸縮接頭
- 62 · 順T接頭
- 62 · 同徑Y型接頭
- 62 · 異徑Y型接頭
- 63 · 清除孔接頭
- 63 · P型存水接頭

8. 下水道及排水用接頭規格

- 64 · 45° L型接頭
- 64 · 90° L型接頭
- 64 · 45° 型單放口(厚)接頭
- 65 · T型接頭
- 65 · 同徑普通接頭
- 66 · 異徑普通接頭
- 66 · 塞頭
- 67 · 順T接頭
- 67 · 45° Y型接頭
- 68 · 清除孔接頭
- 68 · P型存水接頭
- 69 · V型存水接頭
- 69 · 污水防臭接頭
- 70 · 衛生下水道用PVC-U匯流井規格

膠合劑

9. 膠合劑

- 72 | 南亞硬質膠合劑
- 73 | 南亞耐衝擊PVC-U膠合劑

品質 認證

10. 管理標準化 74

11. 生產自動化 75

12. 品管制度化 76

13. 品質認證證書

- 78 | ISO 9001, 14001
品質認證合格證書
- 79 | 各項CNS產品通過
正字標記認證證書



Characteristics and application

1. Characteristics and application of PVC-U Pipe and Fitting 3

2. Chemical and Physical Properties of PVC-U Pipe and Fitting 5

Specification

3. Specification of PVC-U Pipe

- 15 **(1) PVC-U Pipe for General Purpose**
 - 15 · Type VU(A Pipe) Thin Pipe
 - 16 · Type VP(B Pipe) Thick Pipe
 - 17 · Ring-Seal Type VP(B Pipe) for General Use
- 18 **(2) PVC-U Pipe for Water Supply**
 - 18 · Type W
 - 19 · Ring-Seal Type for Water Supply
- 20 **(3) PVC-U Pipe for Electric Conduit Use**
 - 20 · Type E
 - 20 · Type ES-1
- 21 **(4) PVC-U Pipe for High-Impact Use**
- 22 **(5) Ring-Seal Type A for Water Supply**
- 23 **(6) Ring-Seal Type B for Water Supply**
- 23 **(7) PVC-U Pipe for Raft Use (CNS 12698)**
- 24 **(8) Well Drilling Engineering**
- 25 **(9) Pipe With Solvent Cement Socket (Single Socket)**

Installation

4. Installation of PVC-U Pipe

- 26 **(1) Installation of PVC-U Pipe**
- 32 **(2) Notice Items of PVC-U Pipe Instructions**

Fitting Specification

5. Specification of PVC-U Fittings for Water Supply

- 36 · 45° Elbow
- 36 · 90° Elbow
- 37 · Tee
- 37 · Reducer coupling

Fitting Specification

5. Specification of PVC-U Fittings for Water Supply

- 38 · Coupling
- 38 · Reducer coupling
- 39 · Faucet fitting-90° Elbow
- 39 · Faucet fitting -Fixture Tee
- 40 · Faucet fitting-Female Adapter
- 40 · Male adapter(Plastic Thread)
- 41 · Union
- 41 · Cap
- 42 · Compression Fitting

6. Specification of gray fitting (thick and thin)

- 43 · 45° Elbow
- 43 · 90° Elbow
- 44 · 45° Elbow with spigot end
- 44 · 90° Elbow with spigot end
- 44 · 90° Reducer Elbow
- 44 · Tee
- 45 · Reducer Tee
- 46 · Vent Tee
- 46 · Coupling
- 47 · Reducer Coupling
- 48 · Sanitary Tee
- 48 · Reducer Sanitary Tee
- 49 · 45° Wye
- 49 · Reducer Wye
- 49 · Wye With Spigot End
- 50 · Assembly Type Beam Fittings
- 50 · Slab Joint
- 50 · Eccentric Fitting
- 51 · Faucet Fitting-90° Elbow (Plastic Thread)
- 51 · Faucet Fitting-Fixture Tee (Plastic Thread)
- 51 · Faucet Fitting-Female Adapter (Plastic Thread)
- 52 · Male Adapter (Plastic Thread)
- 52 · Cap
- 52 · Cleanout Bushing
- 53 · Flange
- 53 · Hopper
- 53 · Coupling with Waterstop Board
- 53 · Coupling with double Waterstop Board
- 53 · AIR Vent



Fitting Specification

7. Specification for HI high impact PVC-U fittings drainage

- 54 · 45° Elbow
- 54 · 90° Elbow
- 55 · Tee
- 55 · Reducer Tee
- 56 · Coupling
- 56 · Reducer Coupling
- 57 · Cap
- 57 · Flange
- 57 · Union
- 58 · Male Adapter (Plastic Thread)
- 58 · Faucet Fitting (Insert Bronze Nut) -90° Elbow
- 58 · Faucet Fitting (Plastic Thread) -90° Elbow
- 59 · Faucet Fitting (Insert Bronze Nut) -Fixture Tee
- 59 · Faucet Fitting (Plastic Thread) -Fixture Tee
- 60 · Faucet Fitting (Insert Bronze Nut) - Female Adapter
- 60 · Faucet Fitting (Plastic Thread) -Female Adapter
- 61 · Compression Fitting
- 62 · Sanitary Tee
- 62 · Wye
- 62 · Reducer Wye
- 63 · Cleanout Bushing
- 63 · "P" Trap with Solvent Weldjoint And Cleanout Plug

8. Specification of PVC-U Fittings for Sewerage & Drainage

- 64 · 45° Elbow
- 64 · 90° Elbow
- 64 · 45° Elbow With Spigot End
- 65 · Tee
- 65 · Coupling
- 66 · Reducer coupling
- 66 · Cap
- 67 · Sanitary Tee
- 67 · 45° Wye
- 68 · Cleanout Bushing
- 68 · "P" Trap with Solvent Welding Joint and Cleanout Plug
- 69 · "V" Type Water Connection
- 70 · Junction with odor trap
- Specification of PVC-U Inspection Chambers for Sewerage & Drainage

Vinyl Adhesive

9. Vinyl Adhesive

- 72 | [Nan Ya Vinyl Adhesive](#)
- 73 | [Nan Ya High Impact Vinyl Adhesive](#)

Certification

10. Standardization of Management 74

11. Automated Production 75

12. Institutionalized Quality Control 76

13. Certification

- 78 | [ISO 9001, 14001 Quality Certification](#)
- 79 | [CNS Marks of all Products](#)



PVC-U管及接頭除具有優異之耐藥品性、耐腐蝕、電氣絕緣性、耐燃性外，由於强度高，質輕易於搬運，流體阻力小，不影響水質，價廉又施工簡便，故廣泛應用於給水、電氣、天然氣、化工、農業、漁業、建築、下水道等工程，為目前最普遍、最受歡迎之一種配管良材。

本公司出品之「南亞牌」各型PVC-U塑膠管及接頭，品質最優良，規格最齊全，符合國際水準，並曾獲得經濟部標準檢驗局最早頒發正字標記的榮譽。

目前本公司擁有全國規模最龐大，最新式的塑膠管及接頭生產設備，其產能高居全國之冠，銷售市場亦遍佈全球。今後將持續配合市場之拓展，優化及擴充設備、增加產量，使浩大之產能、準確之交期，優異之品質、良好的服務與信譽更能發揮光大。

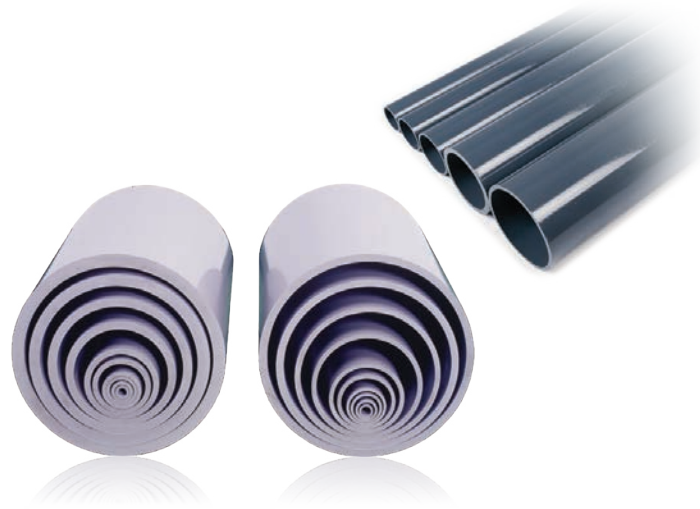

With superb electrical insulation, chemical, corrosion, and fire resistance, PVC-U pipe and fitting are easy for installation and delivery due to these characteristics including high strength, light weight, low fluid resistance, and contaminated-free water quality. As a result, PVC-U pipe and fitting, widely used for various engineering projects such as water supply, electricity, natural gas, chemicals, agriculture, fishery, architecture, and sewage, are one of the most popular and supreme plastic piping materials in the world.

Versatile types of PVC-U pipes and fittings marked with "NAN YA" symbolize the highest quality and fullest specification. Moreover, Nan

Ya Plastics Corp., which has been manufacturing PVC-U pipe and fitting complying with international standards, is the first corporation that acquires "CNS mark" granted by Bureau of Standards, metrology & inspection, M.O.E.A., R.O.C.

At present, Nan Ya Plastics Corp., which owns the most enormous, advanced, and productive production equipment of PVC-U pipe and fitting in Taiwan, has been striving to promote its products to the global market. Furthermore, with the reinforcement of market expansion, Nan Ya Plastics Corp. has been dedicated to introducing equipment and increasing capacity in order to provide tremendous capacity, punctual delivery, excellent quality, and customer-oriented service to you.





PVC-U管 · 接頭特性與用途

Characteristics and applications of PVC-U Pipe and Fitting

1. 質輕，搬運裝卸便利：
PVC-U管材質輕，搬運、裝卸，施工便利，可節省人工。
2. 耐化學藥品性優良：
PVC-U具有優異的耐酸、耐鹼、耐腐蝕性，對於化學工業之用途甚為適合。
3. 流體阻力小：
PVC-U之壁面光滑，對流體之阻力小，其粗糙係數僅0.009較其他管材為低，在相同之流量下，管徑可予以縮小。
4. 機械強度大：
PVC-U之耐水壓強度，耐外壓強度，耐衝擊強度等均甚良好，適用於各種條件之配管工程。
5. 電氣絕緣性佳：
PVC-U富有優越的電氣絕緣性，適用於電線、電纜之導管，與建築上之電線配管。
6. 不影響水質：
PVC-U管由溶解試驗證實不影響水質，為目前自來水配管之最佳管材。
7. 施工簡易：
PVC-U管之接合施工迅速容易，故施工工程費用低廉。

1. Light Weight, easy to load and unload :
PVC-U pipe is very light, convenient to handle loading unloading, and installing. May save much labor.
2. Good chemicals and drugs resistance :
PVC-U pipe has its excellent resistance to the erosion caused by acids and alkalines, a great help to the chemical industries.
3. Small resistance to fluidity :
The smooth surface of PVC-U pipe reduces resistance to the fluids. Its roughness coefficient is only 0.009, much less than other pipes. Under same discharge, smaller calibre of the pipe can be used.
4. Strong mechanical strength :
Good resistance to water pressure, outside impact and pressure, is satisfied under any conditions.
5. Good electrical insulation :
PVC-U pipe has excellent insulation nature against electricity. It can be served as conduits and pipes in construction cable and wire.
6. Water quality unaffected :
The solution tests on the PVC-U pipe show no affect on water quality when the water flows through it. It is considered the best piping material for running water works.
7. Simple installation :
Very easy to connect, thus much time and labor cost may be saved.

PVC-U管 · 接頭適用場所

Applications of PVC-U Pipe and Fitting

1. 自來水工程 Drinking water engineering
2. 電氣工程 Electrical engineering
3. 建築工程 Architectural engineering
4. 下水道工程 Sewer engineering
5. 電信工程 Telecommunications engineering
6. 鑿井工程 Well drilling engineering
7. 鹽水工程 Salt water engineering
8. 天然氣工程 Natural Gas engineering
9. 化學工程 Chemical engineering



建築工程 Architectural engineering



電導管工程 Electrical engineering



養殖輸水工程 Water Supply engineering

1

PVC-U管 · 接頭特性與用途

Characteristics and applications of PVC-U Pipe and Fitting

10. 製紙工程 Paper mill
11. 釀造醱酵工程 Acidifying & Fermenting plant
12. 電鍍工程 Electroplating factory
13. 農業園地 Agricultural Ground
14. 礦場 Mining Plant
15. 養殖業 Aquaculture
16. 高速公路工程 Freeway engineering
17. 高爾夫球場工程 Golf course engineering
18. 漁業用塑膠筏 Plastic fish raft



鑿井工程 Well drilling engineering



漁業用塑膠筏工程 Plastic fish raft



化學工程 Chemical engineering



冷凍空調工程 Air Conditioning project



下水道工程 Sewer Engineering



農田灌溉工程 Irrigation engineering

2 PVC-U管 · 接頭之物理及化學性質 Chemical and Physical Properties of PVC-U Pipe and Fitting

(一) 物理性質 Physical Properties

1. 一般用PVC-U管 PVC-U Pipe for General Purpose

試驗項目 Test Items		試驗值 Test Value	試驗標準 Test standard
抗拉降伏強度試驗 Tensile Strength Test		45MPa ↑ (23°C)	CNS 1298 K3004
直管耐水壓性 Water pressure resistance of PVC-U pipe		無漏水，破裂及變形現象 Non-broken	
接合部耐水壓性 ^(a) Water pressure resistance of joints		無洩漏現象 No Leakage	
耐壓扁性 Flattening Test		無破裂或龜裂現象 Non-broken	
比重 Specific Gravity		1.40~1.44	
衛氏軟化溫度 Vicat softening Temperature		76°C ↑	
浸漬性試驗 Immersion Test	蒸餾水 Distilled Water	±0.2mg/cm ²	
	10% 氯化鈉溶液 10% Sodium Chloride Solution		
	30% 硫酸溶液 30% Sulfuric Acid Solution		
	40% 氫氧化鈉溶液 40% Sodium Hydroxide Solution		
	40% 硝酸溶液 40% Nitric Acid Solution		

註：(a)接合部耐水壓性適用於活套頭承口(VP)及接著型承口(VP及VU)之管，此等管應以接合部耐水壓試驗替代該管耐水壓試驗。

Note: (a) The water pressure resistance of the joint is applicable to the tubes with loose bushes (VP) and adhesive sockets (VP and VU). This type of pipe should proceed the hydrostatic test of the joint.

PVC-U管水壓試驗 (CNS 1298 K3004) Hydrostatic Test for PVC-U Pipe

種類 Categories	VP(B)管(厚管) Type VP(B)(Thick Wall)	VU(A)管(薄管) Type VU(A)(Thin Wall)
標稱管徑(mm) Nominal Pipe Size	13~600	40~700
試驗壓力(kgf/cm ²) Test Pressure	25.5	15.3
20°C使用壓力(Kgf/cm ²) Allowable working pressure at 20°C	7.65	2.55

活套接頭水壓試驗

Hydrostatic Test for PVC-U Fitting

單位Unit : mm

用途別 Application	標稱管徑 Nominal Pipe Size														
	40	50	65	80	100	125	150	200	250	300	350	400	450	500	600
自來水用W管(kgf/cm ²)	35.7														
一般用(kgf/cm ²)	25.5														

2 PVC-U管 · 接頭之物理及化學性質 Chemical and Physical Properties of PVC-U Pipe and Fitting

2. 自來水用PVC-U管 PVC-U Pipe for Water Supply

試驗項目 Test Item	試驗值 Test Value	試驗標準 Test standard	
抗拉降伏強度試驗 Tensile Strength Test	45MPa ↑ (23°C)	CNS 4053-1 K3033-1	
直管耐水壓性 Water pressure resistance of PVC-U pipe	無破裂或龜裂現象 Non-broken		
接合部耐水壓性 ^(a) Water pressure resistance of joints	無洩漏現象 No Leakage		
耐壓扁性 Flattening Test	無破裂或龜裂現象 Non-broken		
比重 Specific Gravity	1.40~1.44		
衛氏軟化溫度 Vicat Softening Temperature Test	76°C ↑		
不透明性 Opaque	可見光透光率為0.2% ↓ Transmittance 0.2% ↓		
管材VCM含量 Material's VCM Content	1.0ppm ↓		
溶出性 Extraction Test	濁度 ^(b) Turbidity		0.2NTU ↓
	色度 Colourness		0.5度/degree ↓
	總有機碳(TOC)		1.0ppm ↓
	鉛及其化合物 Pb Extraction		0.005ppm ↓
	鋅及其化合物 Zn Extraction		0.5ppm ↓
	餘氯減量 Loss of Residual Chlorine		0.7ppm ↓
	臭氣及異味 Odor and Taste	無不良氣味 Not Detectable	
	VCM溶出量 VCM Extraction	0.0015ppm ↓	

註： (a)接合部耐水壓性適用於活套頭承口及接著型承口之管，此等管應以接合部耐水壓試驗替代該管耐水壓試驗。
(b)依濁度計法，單位為NTU。

Note: (a) The water pressure resistance of the joint is applicable to the tubes with loose bushes (VP) and adhesive sockets (VP and VU). This type of pipe should proceed the hydrostatic test of the joint.
(b) In Accordance with the turbidity method. (Unit: NTU)

自來水用PVC-U管水壓試驗 (CNS 4053-1 K3033-1) Hydrostatic Test for PVC-U Pipe for Water Supply

標稱管徑(mm) Nominal Pipe Size	13	16	20	25	30	40	50	65	80	100	125	150	200	250	300	350	400	450	500	600	
試驗壓力 (kgf/cm ²) Test Pressure	40.8																				
20°C使用壓力 (Kgf/cm ²) Allowable working pressure at 20°C	7.65 ↓																				

註： 接合部(包括活套管及接著型管) 35.7kgf/cm²

Note: Hydraulic internal pressure test of ring-seal joint : 35.7kgf/cm²

2

PVC-U管 · 接頭之物理及化學性質

Chemical and Physical Properties of PVC-U Pipe and Fitting

3. 耐衝擊PVC-U管 High-Impact PVC-U Pipe

試驗項目 Test Items		試驗值 Test Value	試驗標準 Test Standard
抗拉降伏強度試驗 Tensile Strength Test		40 MPa _p [408kgf/cm ²] ↑ (23°C)	CNS 14345 K3114
直管耐水壓性 Water pressure resistance of PVC-U pipe		無漏水、破裂及變形現象 Non-broken	
接合部耐水壓性 ^(a) Water pressure resistance of joints		無洩漏現象 No Leakage	
耐壓扁性 Flattening Test		無破裂或龜裂現象 Non-broken	
耐衝擊性 Impact Test		沙丕(Charpy) 10kJ/m ² ↑ (0°C)	
耐落錘衝擊性 Impact Test		無異常現象 Normal	
耐候性 Weather Resistance		14kJ/m ² ↑ (23°C)	
衛氏(Vicat)軟化溫度 Vicat Softening Temperature Test		76°C ↑	
管材VCM含量 Material's VCM Content		1.0ppm ↓	
溶出性 Extraction Test	濁度 ^(b) Turbidity	0.2 NTU ↓	
	色度 Colourness	0.5度/degree ↓	
	總有機碳(TOC)	1.0ppm ↓	
	鉛及其化合物 Pb	0.005ppm ↓	
	鋅及其化合物 Zn	0.5ppm ↓	
	餘氯減量 Loss of Residual Chlorine	0.7ppm ↓	
	臭氣及異味 Odor and Taste	無不良氣味 Not Detectable	
浸漬性 Immersion Test	氯乙烯單體 VCM	0.0015ppm ↓	
	蒸餾水 Distilled Water	±0.2mg/cm ²	
	10% 氯化鈉溶液 10% Sodium Chloride Solution		
	30% 硫酸溶液 30% Sulfuric Acid Solution		
	40% 氫氧化鈉溶液 40% Sodium Hydroxide Solution		
	40% 硝酸溶液 40% Nitric Acid Solution		
比重(23°C) Specific Gravity	1.35~1.40		

註： (a)接合部耐水壓性適用於活套頭承口及接著型承口之管，此等管應以接合部耐水壓試驗替代該管耐水壓試驗。
(b)依濁度計法，單位為NTU。

Note: (a)The water pressure resistance of the joint is applicable to the tubes with loose bushes (VP) and adhesive sockets (VP and VU). This type of pipe should proceed the hydrostatic test of the joint.
(b) In Accordance with the turbidity method. (Unit: NTU)

耐衝擊PVC-U管水壓試驗 Hydrostatic Test of High-Impact PVC-U Pipe

標稱管徑(mm) Nominal Pipe Size		13	16	20	25	30	40	50	65	80	100	125	150	200	250	300	350	400	
試驗壓力(MPa) Test Pressure	自來水用管 Drinking Water	4.0[40.8kgf/cm ²]																	
	一般用管 General Use	2.5 [25.5kgf/cm ²]																	
20°C使用壓力 (MPa) Working pressure at 20°C	自來水用管 Drinking Water	0.75 [7.65kgf/cm ²] ↓																	
	一般用管 General Use	0.75 [7.65kgf/cm ²] ↓																	

註： 1. 接合部(包括活套管及接著型管)之試驗水壓為：
自來水用3.5MPa (35.7kgf/cm²)一般用2.5MPa (25.5kgf/cm²)
2. 壓力換算：1MPa = 10.2 kgf/cm²

Note: 1. After the hydrostatic test, water pressure of the joint (including loose pipe and adhesive pipe) is:
3.5MPa (35.7kgf/cm²) for tap water pipe and 2.5MPa (25.5kgf/cm²) for general pipe.
2. Pressure conversion: 1MPa = 10.2 kgf / cm²

2

PVC-U管 · 接頭之物理及化學性質

Chemical and Physical Properties of PVC-U Pipe and Fitting

耐衝擊試驗之試驗高度與重錘質量 Falling Height and Weight Impact Test.

標稱管徑(mm) Nominal Pipe Size	13	16	20	25	30	40	50	65	80	100	125	150	200	250	300	350	400	
落錘高度(cm) Fall height	100	125	150	200	100	150	200	75	100	150	175	200	225	275	325	-	-	
重錘形狀 Shape	圓柱狀平底形 Flat Cylinder							圓錐狀 Cone										
重錘質量(Kg) Falling weight	1±0.05				3±0.05				9±0.05									

註：標稱管徑350及400之重錘落下高度得依當事人間協議之。

Note: The drop height of the weight (Nominal pipe size: 350 & 400) shall be agreed by mutual parties.

耐衝擊試驗的重錘形狀與質量

The form and weight of falling weight in impact test.



4. PVC-U電線導管 PVC-U Pipe for Electrical Conduit Use

試驗項目 Test Items	試驗值 Test Value	試驗標準 Test standard
耐壓扁性 Flattening Test	載重1250 ⁺⁵⁰ N時，外徑的減少率在25%以下，除去載重後減少率應在10%以下，且試樣以目視檢查不得有裂紋或破裂現象 When the load is 1250 ⁺⁵⁰ N, the reduction rate of the outside diameter is 25% or less, remove the load reduction rate should be below 10% and visual inspection of the sample should not have cracks.	CNS 1302 K3006
耐衝擊性 Impact Test	12個試樣試驗後，9個以上之試樣無破壞，以目視檢查無裂紋或破裂現象，而且不能有妨礙正常使用之變形 After test 12 specimens, more than 9 specimens shall be examined for visual inspection without cracks, and shall not be deformed to prevent normal use.	
絕緣性 Insulation Test	試驗中不得有跳脫動作 There shall be no tripping action in the test.	
絕緣電阻 Insulation Resistance	100 MΩ以上 Above 100MΩ	
耐燃性 Flammability	3個試樣應全部符合。移開火源後，火燄須在30秒內自然熄滅 All 3 specimens shall meets requirements. Remove the fire source, the flame must be naturally extinguished within 30 seconds.	
耐熱性 Heat Resistance	塞規僅以本身質量通過管內 The plug is only passed through the pipe with its own mass.	

2

PVC-U管·接頭之物理及化學性質

Chemical and Physical Properties of PVC-U Pipe and Fitting

5. 管筏用PVC-U管 PVC-U Pipe for Raft Use

試驗項目 Test Items		試驗值 Test Value	試驗標準 Test standard
抗拉強度試驗 Tensile Strength Test		500kgf/cm ² ↑	CNS 12698 K3094
壓扁試驗 Flattening Test		不破裂 Non-broken	
比重 Specific Gravity		1.42±0.03	
灰分試驗 Ash Content Test		4% ↓	
落錘衝擊試驗 Drop Weight Impact Test		不破裂 Non-broken	
沙丕耐衝擊強度 Charpy Impact Strength		5.0kgf-cm/cm ² ↑	
耐藥品性 Chemical Resistance	10%氯化鈉溶液 10% Sodium Chloride Solution	±0.2mg/cm ²	
	40%氫氧化鈉溶液 40% Sodium Hydroxide Solution		
	柴油 Diesel fuels		
耐候性 Weather Resistance	沙丕耐衝擊試驗變化率 Charpy Impact Change Ratio	80% ↑	

6. PVC-U接頭配件（給水用） PVC-U Fitting (Water Supply)

性能項目 Test Items		品質要求 Quality Requirement	試驗標準 Test standard
抗拉降伏強度 ^(a) Tensile Strength Test		45MPa ↑ (23°C)	CNS 2334 K3011
耐水壓性 Hydraulic internal pressure		無漏水，破裂及變形現象 Non-broken	
耐壓扁性 ^(b) Flattening Test		無破裂或龜裂現象 Non-broken	
衛氏(Vicat)軟化溫度 Vicat Softening temperature		72°C ↑	
管材氯乙烯單體(VCM)含量 Material's VCM Content		1.0 mg/L以下 below 1.0 mg/L	
溶出性 Extraction Test	鉛及其化合物 (Pb)	0.005mg/L (Pb) ↓	
	鋅及其化合物 (Zn)	0.5mg/L (Zn) ↓	
	總有機碳 (TOC)	1.0 mg/L ↓	
	臭氣及異味 Odor and Taste	無不良氣味 Not Detectable	
	濁度 ^(c) Turbidity	0.2 NTU ↓	
	色度 Colourness	0.5度/degree ↓	
	餘氯減量 Oss of residual Chlorine	0.7 mg/L ↓	
	氯乙烯單體(VCM) VCM Extraction	0.0015 mg/L ↓	
非PVC組件之溶出性 Non-PVC products		符合表2之規定 In compliance with rules Table 2	
比重 Specific Gravity		1.35~ 1.40	

註: (a)若無法採取抗拉降伏強度試驗之試片(承口長度小於100mm)時,則免予試驗。

(b)僅適用於手工管件。

(c)依濁度計法,單位為NTU。

(d)壓力換算:1MPa = 10.2 kgf/cm²

Note:(a) If the tensile strength test for sample (Socket length less than 100 mm) is not available, the test can be exempted.

(b) Only applicable to manual pipe accessories.

(c) According to turbidimetry, the unit is NTU.

(d) Pressure conversion: 1MPa = 10.2 kgf / cm²

2 PVC-U管 · 接頭之物理及化學性質 Chemical and Physical Properties of PVC-U Pipe and Fitting

7. PVC-U耐衝擊接頭配件（給水用） High-Impact PVC-U Fitting (Water Supply)

試驗項目 Test Items		試驗值 Test Value	試驗標準 Test standard
抗拉強度 Tensile Strength Test		40MPa [408kgf/cm ²] ↑ (23°C)	CNS 15010 K3126
耐水壓 Hydraulic pressure		4.0MPa[40.8kgf/cm ²]x1min	
沙丕耐衝擊 Charpy Impact Test	耐候前 Before Weathering	10kJ/m ² ↑ (0°C)	
	耐候後 After Weathering	14kJ/m ² ↑ (23°C)	
耐落錘衝擊 Drop Weight Impact Test		無異常現象 Normal	
衛氏(Vicat)軟化溫度 Vicat Softening temperature		72°C ↑	
接頭材料VCM含量 Material's VCM content		1.0 mg/L ↓	
溶出性 Extraction Test (給水用) (Water Supply)	濁度 Turbidity	0.2度/degree ↓	
	色度 Colourness	0.5度/degree ↓	
	鉛 Pb	0.005mg/L ↓	
	鋅 Zn	0.5 mg/L ↓	
	餘氯減量 Loss of Residual Solution	0.7 mg/L ↓	
	臭氣及異味 Odor and Taste	無不良氣味 Not Detectable	
浸漬性 Immersion Test (一般用) (General Use)	蒸餾水 Distilled Water	±0.20mg/cm ²	
	10%氯化鈉溶液 10% Sodium Chloride Solution		
	30%硫酸 30% Sulfuric Acid Solution		
	40%氫氧化鈉溶液 40% Sodium Hydroxide Solution		
	40%硝酸 40% Nitric Acid Solution		



(二) 化學性質 Chemical Properties

下列為化學抗性術語中所用之代表字。

- ：有良好的抗性，不起作用可使用。
- ：略加注意可使用。
- ×：不能使用。

Followings are terms of chemical resistance:

- ：Superb resistance; usable without chemical reaction
- ：Usable with care.
- ×：Unusable.

化學品 CHEMICAL	23°C 60°C	化學品 CHEMICAL	23°C 60°C
乙醛 Acetaldehyde	× ×	鋇鹽 Barium salts	○ ○
乙醛 40°C水溶液 Acetaldehyde, aq 40%	○ ×	啤酒 Beer	○ ○
乙醯胺 Acetamide	— —	甜菜糖溶液 Beet sugar liquor	○ ○
醋酸蒸氣 Acetic acid, vapor	○ ○	苯甲醛10%溶液 Benzaldehyde, 10%	○ ×
冰醋酸 Acetic acid, glacial	○ ×	苯甲醛10%以上 Benzaldehyde, above 10%	× ×
20%醋酸 Acetic acid, 20%	○ ○	苯 Benzene(benzol)	× ×
80%醋酸 Acetic acid, 80%	○ ○	苯磺酸10% Benzene sulfonic acid, 10%	○ ○
醋酸酐 Acetic anhydride	× ×	苯磺酸 Benzene sulfonic acid	× ×
丙酮 Acetone	× ×	苯甲酸(安息香酸) Benzoic acid	○ ○
乙炔(電石氣) Acetylene	○ ○	黑液(紙廠) Black liquor-paper	○ ○
己二酸 Adipic acid	○ ○	漂液12.5%有效氯 Bleach, 12.5% active chlorine	○ ○
丙烯醇 Alcoo, allyl	○ ○	漂液5.5%有效氯 Bleach, 5.5% active chloride	○ ○
丁基苯甲醇 Alcohol, butyl benzyl	× ×	硼砂 Borax	○ ○
丁醇(正丁醇) Alcohol, butyl (n-butanol)	○ ○	硼酸 Boric acid	○ ○
丁醇(丁醇-2) Alcohol, butyl (2-butanol)	○ ×	三氟化硼 Boron trifluoride	○ ○
乙醇 Alcohol, ethyl	○ ○	溴酸 Bromic acid	○ ○
六烷醇 Alcohol, hexyl	○ ○	液溴 Bromine, liquid	× ×
異丙醇(丙醇-2) Alcohol, isopropyl (2-propanol)	○ ○	25%溴氣 Bromine, gas, 25%	○ ○
甲醇 Alcohol, methyl	○ ○	溴水 Bromine, aq	○ ○
丙醇 Alcohol, propyl (1-propanol)	○ ○	丁二烯 Butadiene	○ ○
氯丙烯 Allyl chloride	× ×	丁烷 Butane	○ ○
明礬 Alums	○ ○	丁四醇 Butantetrol(erythritol)	○ ×
氣氨 Ammonia, gas	○ ○	丁二醇 Butanediol	○ ○
液氨 Ammonia, liquid	× ×	醋酸丁酯 Butyl acetate	× ×
氨水 Ammonia, aq	○ ○	丁基酚 Butyl phenol	○ ×
銨鹽(除氟化物) Ammonium salts, except fluoride	○ ○	丁烯 Butylene	○ ○
氟化銨25% Ammonium fluoride, 25%	○ ○	丁酸 Butyric acid	○ ×
醋酸戊酯 Amylacetate	× ×	鈣鹽水溶液 Calcium Salts aq	○ ○
苯胺 Aniline	× ×	次氯酸鈣 Calcium hypochlorite	○ ○
氯化苯胺 Aniline chlorohydrate	× ×	氫氧化鈣 Calcium hydroxide	○ ○
苯胺鹽酸鹽 Aniline hydrochloride	× ×	蔗糖液 Cane sugar liquors	○ ○
苯胺染(素)料 Aniline dyes	× ×	二硫化碳 Carbon bisulfide	× ×
蒽醌料 Anthraquinone	○ ○	二氧化碳 Carbon dioxide	○ ○
蒽醌磺酸 Anthraquinone sulfonic acid	○ ○	二氧化碳水溶液 Carbon dioxide, aq	○ ○
三氯化銻 Antimony trichloride	○ ○	一氧化碳 Carbon monoxide	○ ○
王水 Aqua regia	○ ×	四氯化碳 Carbon tetrachloride	○ ×
砷酸80% Arsenic acid, 80%	○ ○	酪蛋白 Casein	○ ○
苯基化磺酸 Aryl-sulfonic acid	○ ○	蓖麻油 Castor oil	○ ○

2

PVC-U管 · 接頭之物理及化學性質

Chemical and Physical Properties of PVC-U Pipe and Fitting

化學品 CHEMICAL	23°C 60°C	化學品 CHEMICAL	23°C 60°C
苛性鉀 (氫氧化鉀) Caustic potash (potassium hydroxide)	○ ○	鄰、苯二甲酸二丁酯 Dibutyl phthalate	× ×
苛性鈉 (氫氧化鈉) Caustic Soda (sodium hydroxide)	○ ○	癸二酸二丁酯 Dibutyl sebacate	○ ×
賽璐蘇 Cellosolve	○ ○	二氯化苯 Dichlorobenzene	× ×
醋酸纖維素賽璐蘇溶液 Cellosolve acetate	○ —	二氯乙烯 Dichloroethylene	× ×
三氯乙醛水化物 Chloral hydrate	○ ○	醚類 Ethers	× ×
氯胺 Chloramine	○ —	乙酯類 Ethyl esters	× ×
20%氯酸 Chloric acid, 20%	○ ○	鹵化乙烷類 Ethyl esters	× ×
氯氣 (乾) Chlorine, gas ,dry	○ ×	鹵化乙烯類 Ethylene halides	× ×
氯氣 (濕) Chlorine, gas ,wet	× ×	乙二醇 Ethylene glycol	○ ○
液氯 Chlorine, liquid	× ×	環氧乙烷 Ethylene oxide	× ×
氯水 Chlorine water	○ ○	脂肪酸 Fatty acids	○ ○
氯化醋酸 Chloracetic acid	○ ○	鐵鹽 Ferric salts	○ ○
氯苯 Chlorobenzene	× ×	氟氣 (乾) Fluorine, dry gas	○ ×
氯化氯甲苯 Chlorobenzyl chloride	× ×	氟氣 (濕) Fluorine, wet gas	○ ×
氯仿 (三氯甲烷) Chloroform	× ×	氟硼酸25% Fluoboric acid, 25%	○ ○
氯磺酸 Chlorosulfonic acid	○ ×	氟矽酸 Fluosilicic acid	○ ○
鉻酸10% Chromic acid, 10%	○ ○	甲醛 Formaldehyde	○ ○
鉻酸30% Chromic acid, 30%	○ ○	蟻酸 Formic acid	○ ×
鉻酸40% Chromic acid, 40%	○ ○	冷媒—F11, F12, F113, F114 Freon-F11, F12, F113, F114	○ ○
鉻酸50% Chromic acid, 50%	○ ○	冷媒—F21, F22 Freon-F21, F22	× ×
檸檬酸 Citric acid, 20%	○ ○	小果汁及果肉 Fruit juices and pulps	○ ○
椰子油 Coconut oil	○ ○	燃料油 Fuel oil	○ ×
煉碳爐氣 Coke oven gas	○ ○	呋喃醛 Furfural	× ×
銅鹽水溶液 Copper salts,aq	○ ○	煤氣 Gas, coal, manufactured	× ×
玉米油 Corn oil	○ ○	天然瓦斯、甲烷 Gas, natural, methane	○ ○
玉米甜漿 Corn syrup	○ ○	汽油 Gasolines	○ ○
棉花子油 Cottonseed oil	○ ○	明膠 (動物膠) Gelatin	○ ○
甲酚 Cresol	× ×	甘油 (丙三醇) Glycerine (Glycerol)	○ ○
甲基苯甲酸 Cresylic acid, 50%	○ ○	二醇類 Gglycols	○ ○
乙醛巴豆 Croton aldehyde	× ×	動物膠 Glue, animal	○ ○
天然油 (原油) Crude oil	○ ○	羥化醋酸 HOCH2COOH Glycolic acid	○ ○
環己烷 Cyclohexane	× ×	綠液二紙廠 Green liquor, paper	○ ○
環己醇 Cyclohexanol	× ×	沒食子酸 Gallic acid	○ ○
環己酮 Cycohexanone	× ×	庚烷 Heptane	○ ○
重氮鹽 Diazo salts	○ ○	己烷 Hexane	○ ○
柴油 Diesel fuels	○ ○	20%氫溴酸 Hydrobromic acid, 20%	○ ○
二乙基胺 Diethyl amine	× ×	鹽酸 Hydrochloric acid	○ ○
鄰、苯二甲酸、二辛酯 Dioctyl phthalate	× ×	10%氫溴酸 Hydrobromic acid, 10%	○ ○
磷酸二鈉 Disodium phosphate	○ ○	60%氫溴酸 Hydrobromic acid, 60%	○ ○
乙二胺酸鹽 Diglycolic acid	○ ○	100%氫溴酸 Hydrobromic acid, 100%	○ ○
1.4—二噁烷 dioxane-1.4	× ×	氫氰酸 Hydrocyanic acid	○ ○
二甲基胺 Dimethylamine	○ ○	氫 Hydrogen	○ ○
二甲基甲醯胺 Dimethyl formamide	× ×	50%過氧化氫 Hydrogen peroxide, 50%	○ ○
清潔劑水溶液 Detergents, aq	○ ○	90%過氧化氫 Hydrogen peroxide, 90%	○ ○
		硫化氫水溶液 Hydrogen sulfide, aq	○ ○

2

PVC-U管 · 接頭之物理及化學性質

Chemical and Physical Properties of PVC-U Pipe and Fitting

化學品 CHEMICAL	23°C 60°C	化學品 CHEMICAL	23°C 60°C
硫化氫、乾 Hydrogen sulfide, dry	○ ○	甲基磺酸 Methyl sulfonic acid	○ ○
對苯二酚 Hydroquinone	○ ○	二溴甲烷 Methylene bromide	× ×
羥胺鹽 Hydroxylamine sulfate	○ ○	二氯甲烷 Methylene chloride	× ×
聯胺 Hydrazine	× ×	二碘甲烷 Methylene iodine	× ×
二次氯酸 Hypochlorous acid	○ ○	牛奶 Milk	○ ○
3%碘—碘化鉀水溶液 Iodine, in KI, 3%,aq	○ ×	礦物油 Mineral oil	○ ○
碘酒精溶液 Iodine, alc	× ×	混合酸 (硫酸及硝酸) Mixed acids (sulfuric & nitric)	○ ×
10%碘水溶液 Iodine, aq, 10%	× ×	混合酸 (硫酸及磷酸) Mixed acids (sulfuric & phosphoric)	○ ○
噴射燃料JP-4和JP-5 Jet fuels, JP-4 and JP-5	○ ○	糖蜜 Malasses	× ×
煤油 Kerosene	○ ○	一氯化苯 Monochlorobenzene	× ×
酮類 Ketones	× ×	乙醇—胺 Monoethanolamine	× ×
牛皮紙溶液 Kraft paper liquor	○ ○	機車油 Motor oil	○ ○
漆溶劑類 Lacquer thinners	○ ×	石油精 Nophta	○ ○
乳酸25% Lactic acid, 25%	○ ○	奈 Naphthalene	× ×
豬油 Lard oil	○ ○	鎳鹽 Nickel salts	○ ○
十二酸 Lauric acid	○ ○	尼古丁 Nicotine	○ ○
氯化十二烷 Lauryl chloride	○ ○	尼古丁酸 Nicotinic acid	○ ○
硫酸化十二烷 Lauryl sulfate	○ ○	硝酸0至50% Nitric acid, 0 tp 50%	○ ○
鉛鹽 Lead salts	○ ○	硝酸60% Nitric acid,60%	○ ○
石灰硫磺 Lime sulfur	○ ○	硝酸70% Nitric acid,70%	○ ○
亞麻仁油酸 Linoleic acid	○ ○	硝酸80% Nitric acid,80%	○ ○
亞麻仁油 Linseed oil	○ ○	硝酸90% Nitric acid,90%	○ ×
甜酒 Liqueurs	○ ○	硝酸100% Nitric acid,100%	× ×
酒 Liqueurs	○ ○	發煙硝酸 Nitric acid , fuming	× ×
鋰鹽 Lithium salts	○ ○	硝化苯 Nitrobenzene	× ×
潤滑油 Lubricating oils	○ ○	硝化甘油 Nitroglycerine	× ×
機油 Machine Oil	○ ○	亞硝酸 Nitrous acid	○ ○
鎂鹽 Magnesium salts	○ ○	一氧化二氮、氣 Nitrous oxide, gas	○ ○
馬來酸 Maleic acid	○ ○	硝化二醇 Nitroglycol	× ×
蘋果酸 Malic acid	○ ○	硝化丙烷 Nitropropane	○ ○
硫酸錳 Manganese sulfate	○ ○	蔬菜油 Oils, vegetable	○ ○
汞鹽 Mercuric salts	○ ○	油及脂肪 Oils abd fats	○ ○
水銀 (汞) Mercury	○ ○	油酸 Oleic acid	○ ○
異丙二烯丙酮 Mesityl oxide	× ×	發煙硫酸 Oleum	× ×
金屬皂水溶液 Metallic soaps, aq	○ ○	橄欖油 Olive oil	○ —
甲烷 Methane	○ ○	草酸 Oxalic acid	○ ○
醋酸甲酯 Methyl acetate	× ×	氧氣 Oxygen, gas	○ ○
溴化甲烷 Methyl bromide	× ×	臭氧氣 Ozone, gas	○ ○
甲基溶劑 Methyl cellosolve	× ×	棕櫚酸10% Palmitic acid, 10%	○ ○
氯化甲烷 Methyl chloride	× ×	棕櫚酸70% Palmitic acid, 70%	○ ×
甲基甲仿 Methyl chloroform	× ×	石蠟 Paraffin	○ ○
甲基環己酮 Methyl cyclohexanone	× ×	戊烷 Pentane	○ ○
甲基丙烯酸甲酯 Methyl methacrylate	○ —	40%過氯酸 Peracetic acid, 40%	○ ×
水楊酸甲酯 Methyl salicylate	○ ○	10%過氯酸 Peracetic acid, 10%	○ ○
硫酸甲酯 Methyl sulfate	○ ○	70%過氯酸 Peracetic acid, 70%	○ ×

2

PVC-U管 · 接頭之物理及化學性質

Chemical and Physical Properties of PVC-U Pipe and Fitting

化學品 CHEMICAL	23°C 60°C	化學品 CHEMICAL	23°C 60°C
四氯乙烯 Perchloroethylene	○ ○	亞硫酸鹽溶液 Sulfite liquor	○ ○
石油、粗品 Petroleum, sour	○ ○	硫磺 Sulfur	○ ○
酚 Phenol	○ ×	糖溶液 Sugars, aq	○ ○
苯胼碳 Phenylcarbinol	× ×	二氧化硫、乾 Sulfur dioxide, aq	○ ○
苯胼 Phenylhydrazine	× ×	二氧化硫、濕 Sulfur dioxide, wet	○ ○
苯胼 HCl Phenylhydrazine HCl	○ ×	三氧化硫、乾 Sulfur dioxide, aq	○ ○
光氣液態氣態 Phosgene, liquid, gas	○ ○	三氧化硫、濕 Sulfur dioxide, wet	○ ○
液化光氣 Phosgene, liquid	× ×	硫酸至70% Sulfuric acid, up to 70%	○ ○
磷酸 Phosphorus, acid	○ ○	硫酸70%~90% Sulfuric acid, 70 to 90%	○ ○
黃磷 Phosphorus, yellow	○ ○	硫酸90%~100% Sulfuric acid, 90 to 100%	○ ×
紅磷 Phosphorus, red	○ ○	亞硫酸 Sulfurous acid	○ ×
五氧化二磷 Phosphorus pentoxide	○ ○	妥爾油 Tall oil	○ ○
三氯化磷 Phosphorus trichloride	× ×	丹寧酸 Tannic acid	○ ○
照片化學藥品水溶液 Photographic chemicals, aq	○ ○	丹寧酒 Tanning liquors	○ ○
鄰一苯二甲酸 Phthalic acid	○ ○	酒石酸 Tartaric acid	○ ○
苦味酸 Picric acid	× ×	四氯乙烷 Tetrachloroethane	○ ○
金屬溶劑 Plating solutions, metal	○ ○	四乙鉛 Tetraethyl lead	○ ○
鉀鹽水溶液 Potassium salts, aq	○ ○	四氫呋喃 Tetrahydrofuran	× ×
過錳酸鉀25% Potassium permanganate, 25%	○ ○	二氯化硫(SOCl ₂) Thionyl chloride	× ×
烷磺酸鉀 Potassium alkyl xanthates	○ ×	線切油 Thread cutting oils	○ —
丙烷 Propane	○ ○	一烯帖醇(香油腦) Terpeneol	○ ○
二氯丙烷 Propylene dichloride	× ×	四氯化鈦 Titanium tetrachloride	○ ×
丙二醇 Propylene glycol	○ ○	甲苯 Toluene	× ×
環氧丙烯 Propylene oxide	× ×	磷酸三丁酯 Tributyl phosphate	× ×
吡啶 Pyridine	× ×	檸檬酸三丁酯 Tributyl citrate	○ —
焦性沒食子酸 Pyrogallic acid	○ ○	磷酸三甲酚酯 Tricresyl phosphate	× ×
螺紫凝結浴液 Rayon coagulation bath	○ ○	三氯化醋酸 Trichloroacetic acid	○ ○
海水 Sea water	○ ○	三氯乙烯 Trichloroethylene	× ×
水楊酸 Salicylic acid	○ ○	三乙醇胺 Triethanolamine	○ ○
水楊醛 Salicylaldehyde	○ ○	三乙基胺 Triethylamine	○ ○
石西酸 Selenic acid	○ ○	松節油 Turpentine	○ ○
下水道之污物住宅區 Sewage, residential	○ ○	尿素 Urea	○ ○
矽酸 Silicic acid	○ ○	尿 Urine	○ ○
矽油 Silicone oil	○ ×	凡士林 Vaseline	× ×
銀鹽 silver salts	○ ○	蔬菜油 Vegetable oils	○ ○
肥皂 Soaps	○ ○	醋 Vinegar	○ ○
鈉鹽、溶液 Sodium salts, aq, except	○ ○	醋酸乙烯 Vinyl acetate	× ×
氯化鈉(食鹽) sodium chlorite	○ ○	蒸餾水 Water, distilled	○ ○
氯酸鈉 Sodium chlorate	○ ○	活水 Water, fresh	○ ○
重鉻酸鈉、酸 Sodium dichromate, acid	○ ○	地下水 Water, mine	○ ○
過硼酸鈉 Sodium perborate	○ ○	鹽水 Water, salt	○ ○
氯化錫 Stannic chloride	○ ○	龍頭水 Water, tap	○ ○
二氯化錫 Stannous chloride	○ ○	威士忌 Whiskey	○ ○
澱粉 Starch	○ ○	酒 Wines	○ ○
硬脂酸 Stearic acid	○ ○	二甲苯 Xylene	× ×
斯多德爾溶劑 Stoddard solvent	× ×	鋅鹽 Zinc salts	○ ○

※ 化學抗性資料僅提供參考用

Information about chemical resistance is for reference only

3 PVC-U管規格 Specification of PVC-U Pipe

(一) 一般用管 PVC-U Pipe for General Purpose (CNS 1298)

*VU (A管) 一般薄管

TYPE VU (A Pipe) Thin Pipe

單位 Unit : mm

標稱管徑 Nominal Pipe Size		外徑 Outside Diameter		厚度 Wall Thickness		近似內徑 (參考) Approx. Inside Diameter	質量 (參考) Approx. Weight (kg/m)	20°C 使用壓力 Working Pressure at 20°C (kgf/cm ²)	長度 Length (m)
		基準尺度 Reference Diameter	平均外徑之 許可差 ^(a) Tolerance of mean outside Diameter ^(a)	最小 Minimum	許可差 Tolerance				
40	1½"	48	± 0.2	1.8	+ 0.4	44	0.413	2.55	4m
50	2"	60				56	0.521		4m
65	2½"	76	± 0.3	2.2	+ 0.6	71	0.825		4m
80	3"	89				83	1.159		4m
90	3½"	100	± 0.4	3.1	+ 0.8	94	1.476		4m
100	4"	114				107	1.737		4m
125	5"	140	± 0.5	4.1	+ 0.8	131	2.739		5m
150	6"	165				154	3.941		5m
200	8"	216	± 0.7	6.5	+ 1.0	202	6.572		6m
250	10"	267	± 0.9	7.8	+ 1.2	250	9.758		6m
300	12"	318	± 1.0	9.2	+ 1.4	298	13.701		6m
350	14"	370	± 1.2	10.5		348	18.051		6m
400	16"	420	± 1.3	11.8	+ 1.6	395	23.059		6m
450	18"	470	± 1.5	13.2	+ 1.8	442	28.875		6m
500	20"	520	± 1.6	14.6	+ 2.0	489	35.346		6m
600	24"	630	± 3.2	17.8	+ 2.8	592	52.678		6m

註/NOTE :

1. ^(a)平均外徑許可差係指在任意截面之圓周測定值除以圓周率3.142所得之值，或在圓周上等間隔之兩處外徑測定值之平均值(平均外徑)與基準尺度之差。

2. 管材長度可由買賣雙方協議。

1. ^(a)The tolerance of means outside diameter is the difference between the value obtained by dividing the circumference of randomly picked cross-section by the circular constant, 3.142, or the mean of measured value of outside diameter in two directions with mutually equal interval in a randomly picked cross-section (mean outside diameter) and the reference dimension.

2. Pipe length can be determined by the buyer and seller agreement.

3 PVC-U管規格 Specification of PVC-U Pipe

*VP (B管) 一般厚管 TYPE VP (B Pipe) Thick Pipe

單位 Unit : mm

標稱管徑 Nominal Pipe Size	外徑 Outside Diameter			厚度 Wall Thickness		近似內徑 (參考) Approx. Inside Diameter	質量 (參考) Approx. Weight (kg/m)	20°C 使用 壓力 Working Pressure at 20°C (kgf/cm ²)	長度 Length (m)
	基準尺度 Reference Diameter	最大、最 小外徑之 許可差 ^(a) Tolerance of max. and min outside diameter ^(a)	平均外徑 之 許可差 ^(b) Tolerance of mean outside diameter ^(b)	最小 Minimum	許可差 Tolerance				
13	3/8"	18	± 0.2	± 0.2	2.2	+ 0.6	13	7.65	4m
16	1/2"	22			2.7		4m		
20	3/4"	26			20		4m		
25	1"W	32	± 0.3	± 0.2	3.1	+ 0.8	25	7.65	4m
30	1 1/4"W	38			31		4m		
40	1 1/2"	48			40		4m		
50	2"	60	± 0.4	± 0.3	4.1	+ 1.0	51	7.65	4m
65	2 1/2"	76			67		4m		
80	3"	89			77		4m		
100	4"	114	± 0.5	± 0.4	6.6	+ 1.4	100	7.65	5m
125	5"	140			7.0		5m		
150	6"	165			8.9		6m		
200	8"	216	± 0.6	± 0.5	10.3	+ 1.8	194	7.65	6m
250	10"	267			12.7		6m		
300	12"	318			15.1		6m		
350	14"	370	± 0.7	± 0.9	18.0	+ 2.2	333	7.65	6m
400	16"	420			20.5		6m		
450	18"	470			22.9		6m		
500	20"	520	± 0.8	± 1.0	25.3	+ 3.0	468	7.65	6m
600	24"	630			30.7		6m		

註/NOTE :

- ^(a)最大、最小外徑之許可差係指在任意截面之外徑測定值最大值及最小值(最大、最小外徑)與基準尺度之差。
- 一般壓力用管為淺灰色。
- 下水道及建築物污水用管為橘紅色。
- 其它顏色可經由協議後，予以訂購。
- 管材長度可由買賣雙方協議。

- ^(a)The tolerance of maximum and minimum diameter means the difference between the measured maximum and minimum values of outside diameter in a randomly picked cross-section (maximum and minimum diameter) and the reference dimension.
- PVC pressure pipes for general purposes are light gray.
- PVC pipes for sewerage and sewer lines are reddish-orange.
- The other colors could be produced by deal with customers.
- Pipe length can be determined by the buyer and seller agreement.

*使用時注意事項 / Precautions :

- 在屋外儲存時，應避免直射日光，以不聚積熱氣的方式被蓋帆布等措施。
 - 管不得直接加螺紋。
 - 管不得噴射、塗布或接觸對其材質有不利影響之物質，例：丙酮、稀釋劑、雜酚油(cresol)、殺蟲劑、白蟻驅除劑等。再者，即使上述物質不直接與管件接觸時，例：須注意管淺埋時，若將上述物質灑在地面，則會滲透於地下而侵蝕管。
 - 為降低管路沉陷或溫度變化引起之伸縮等，依需要採取適當措施，例：在適當場所設置可撓性管件。
- When pipes are stored outside, please avoid direct sunlight and cover them with canvas without gathering heat.
 - Don't install threads in pipes.
 - Don't spray, coat or contact pipes with harmful substances, such as acetone, thinner, cresol, insecticide, termite repellent, etc. Furthermore, even if above substances do not directly contact pipes, please note that when the pipe is shallowly buried, if above substances are spilled on the ground, they will penetrate the ground and erode pipes.
 - In order to reduce the expansion and contraction caused by pipeline subsidence or temperature changes, take appropriate measures as needed, for example: install flexible pipes in appropriate places.

3

PVC-U管規格 Specification of PVC-U Pipe

*活套VP (B管) 一般用管 Ring-Seal Type VP (B Pipe) for General Use

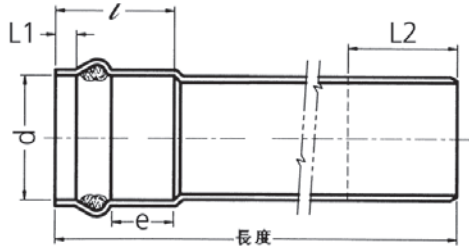

單位 Unit : mm

標稱管徑 Nominal Pipe Size	平均內徑 最小值(d) (min)	有效插入長度 最小值(e) (min)	唇長最小值 (L1) (min)	管承口長度 最小值(l) (min)	雄管插入長度 L2(約) Insert Length of Male Adapter	
40	1½"	48.3	57	12	110	50~55
50	2"	60.3	58	15	115	60~65
65	2½"	76.4	60	20	125	70~75
80	3"	89.5	61	20	130	80~85
100	4"	114.5	64	20	145	95~105
125	5"	140.6	67	25	150	105~115
150	6"	165.7	70	30	165	120~130
200	8"	216.9	76	30	190	170~180
250	10"	268.1	82	30	210	200~210
300	12"	319.3	88	35	235	245~260
350	14"	371.5	89	35	245	285~300
400	16"	421.7	91	35	265	315~330
450	18"	471.9	94	40	290	345~360
500	20"	522.1	96	40	305	385~400
600	24"	633.8	102	45	355	465~480

註： 1. 管材長度可由買賣雙方協議。

2. 標稱管徑200以上之活套頭承口，其承口部分之厚度不得小於直管之厚度。

NOTE: 1. Pipe length can be determined by the buyer and seller agreement.

2. Thickness of loose socket (Nominal pipe size: above 200 mm) must be thinner than that of PVC-U pipe.

*使用時注意事項 / Precautions:

1. 在屋外儲存時，應避免直射日光，以不聚積熱氣的方式被蓋帆布等措施。
 2. 管不得直接加螺紋。
 3. 管不得噴射、塗布或接觸對其材質有不利影響之物質，例：丙酮、稀釋劑、雜酚油(cresol)、殺蟲劑、白蟻驅除劑等。再者，即使上述物質不直接與管接觸時，例：須注意管淺埋時，若將上述物質灑在地面，則會滲透於地下而侵蝕管。
 4. 為降低管路沉陷或溫度變化引起之伸縮等，應依需要採取適當措施，例：在適當場所設置可撓性管件。
 5. 接著劑應薄薄地均勻塗布在已清潔之管與管配件各黏合面，迅速黏合並保持插入力至規定時間。黏合後擦掉所溢出之接著劑。施工時，採取換氣等措施，以驅出管內之接著劑蒸氣。接著既須使用適合於管配件種類者。
1. When pipes are stored outside, please avoid direct sunlight and cover them with canvas without gathering heat.
 2. Don't install threads in pipes.
 3. Don't spray, coat or contact pipes with harmful substances, such as acetone, thinner, cresol, insecticide, termite repellent, etc. Furthermore, even if above substances do not directly contact pipes, please note that when the pipe is shallowly buried, if above substances are spilled on the ground, they will penetrate the ground and erode pipes.
 4. In order to reduce the expansion and contraction caused by pipeline subsidence or temperature changes, take appropriate measures as needed, for example: install flexible pipes in appropriate places.
 5. Vinyl adhesive should be applied evenly and uniformly on the adhesive surfaces of cleaned pipes and their accessories; then, please adhere quickly and maintain the insertion force until the specified time; next, please wipe off vinyl adhesive out of pipes after bonding them. Last, please take measures such as ventilation to expel the vinyl adhesive vapor in pipes during the construction. Therefore, it is necessary to choose suitable pipes to match relative accessories.

3 PVC-U管規格 Specification of PVC-U Pipe

(二) 自來水用管 PVC-U Pipe for Water Supply (CNS 4053-1)

*W管 TYPE W

單位 Unit : mm

標稱管徑 Nominal Pipe Size	外徑 Outside Diameter			厚度 Wall Thickness		近似內徑 (參考) Approx. Inside Diameter	質量 (參考) Approx. Weight (kg/m)	20°C 使用 壓力 Allow working Pressure at 20°C (kgf/cm ²)	長度 Length (m)	
	基準尺度 Reference Diameter	最大、最 小外徑之 許可差 ^(a) Tolerance of max. and min outside diameter ^(a)	平均外徑之 許可差 ^(b) Tolerance of mean outside diameter ^(b)	最小 Minimum	許可差 Tolerance					
13	3/8"	18	± 0.2	± 0.2	2.3	+ 0.4	13	0.174	7.6以下	4m
16	1/2"	22			2.7		+ 0.6	16		0.256
20	3/4"	26			20	0.310		4m		
25	1"W	32			25	0.448		4m		
30	1 1/4"W	38	± 0.3		3.2	+ 0.8	31	0.542		4m
40	1 1/2"	48			3.7		40	0.791		4m
50	2"	60	± 0.4		4.1	+ 0.8	51	1.122		4m
65	2 1/2"	76	± 0.5		67		1.445	4m		
80	3"	89			78		2.202	4m		
100	4"	114	± 0.6		6.6	+ 1.0	100	3.409		5m
125	5"	140	± 0.8	7.0	124		4.464	5m		
150	6"	165	± 1.0	± 0.3	9.0	+ 1.2	146	6.701		6m
200	8"	216	± 1.3		10.8	+ 1.4	194	10.559		6m
250	10"	267	± 1.6	± 0.9	13.3	+ 1.8	239	16.119		6m
300	12"	318	± 1.9	± 1.0	15.9	+ 2.2	285	22.976		6m
350	14"	370	± 2.2	± 1.2	18.0	+ 2.6	332	30.407		6m
400	16"	420	± 2.6	± 1.3	20.5	+ 3.0	376	39.336		6m
450	18"	470	± 3.0	± 1.5	22.9	+ 3.4	421	48.170		6m
500	20"	520	± 3.5	± 1.6	25.3	+ 3.8	466	58.930		6m
600	24"	630	± 4.0	± 3.2	30.7	+ 4.0	565	85.860		6m

註/NOTE :

- ^(a)最大、最小外徑之許可差係指在任意截面之外徑測定值最大值及最小值(最大、最小外徑)與基準尺度之差。
- ^(b)平均外徑許可差係指在任意截面之圓周測定值除以圓周率3.142所得之值，或在圓周上等間隔之兩處外徑測定值之平均值(平均外徑)與基準尺度之差。
- 管材長度可由買賣雙方協議。
- ^(a)The tolerance of maximum and minimum diameter means the difference between the measured maximum and minimum values of outside diameter in a randomly picked cross-section (maximum and minimum diameter) and the reference dimension.
- ^(b)The tolerance of means outside diameter is the difference between the value obtained by dividing the circumference of randomly picked cross-section by the circular constant, 3.142, or the mean of measured value of outside diameter in two directions with mutually equal interval in a randomly picked cross-section (mean outside diameter) and the reference dimension.
- Pipe length can be determined by the buyer and seller agreement.

3 PVC-U管規格 Specification of PVC-U Pipe

* 活套管(自來水用) Ring-Seal Type for Water Supply

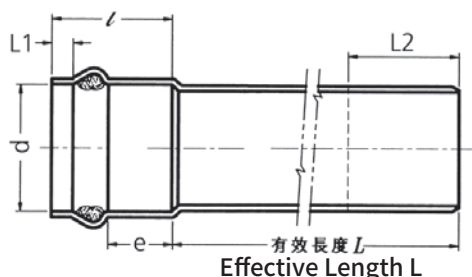

單位 Unit : mm

標稱管徑 Nominal Pipe Size		平均內徑 最小值(d) (min) Mean Inside Diameter	有效插入長度 最小值(e) (min) Insert Effective Length	管承口長度 最小值(ℓ) (min) Sooket Length	雄管插入長度 L 2(約) Insert Length of Male Adapter	有效長度 L
40	1½"	48.3	57	110	50~55	4m
50	2"	60.3	58	115	60~65	4m~7m
65	2½"	76.4	60	125	70~75	4m~7m
80	3"	89.5	61	130	80~85	4m~7m
100	4"	114.5	64	145	90~100	5m~7m
125	5"	140.6	67	150	105~115	5m~7m
150	6"	165.7	70	165	120~130	6m~7m
200	8"	216.9	76	190	170~180	6m~7m
250	10"	268.1	82	210	200~210	6m~7m
300	12"	319.3	88	235	245~260	6m~7m
350	14"	371.5	89	245	285~300	6m~7m
400	16"	421.7	91	265	315~330	6m~7m
450	18"	471.9	94	290	345~360	6m~7m
500	20"	522.1	96	305	385~400	6m~7m
600	24"	633.8	102	355	460~475	6m~7m

註/NOTE:

- 200mm(8")以上為活套增厚管,其承口部分之厚度不得小於直管之厚度。
- 管材長度可由買賣雙方協議。

- Above 200mm(8") is the ring-seal type for drinking water, and its thickness of socket must be thicker than thickness of PVC-U pipe.
- Pipe length can be determined by the buyer and seller agreement.

* 使用時注意事項 / Precautions :

- 在屋外儲存時,應避免直射日光,以不聚積熱氣的方式被蓋帆布等措施。
- 管不得直接加螺紋。
- 管不得噴射、塗布或接觸對其材質有不利影響之物質,例:丙酮、稀釋劑、雜酚油(Creosote)、殺蟲劑、白蟻驅除劑等。再者,即使上述物質不直接與管接觸時,例:須注意管淺埋時,若將上述物質灑在地面,則會滲透於地下而侵蝕管。
- 為降低管路沉陷或溫度變化引起之伸縮等,應依需要採取適當措施,例:在適當場所設置可撓性管件。
- 接著劑應薄薄地均勻塗布在已清潔之管與管配件各黏合面,迅速黏合並保持插入力至規定時間。黏合後擦掉所溢出之接著劑。施工時,採取換氣等措施,以驅出管內之接著劑蒸氣。接著既須使用適合於管配件種類者。

- When pipes are stored outside, please avoid direct sunlight and cover them with canvas without gathering heat.
- Don't install threads in pipes.
- Don't spray, coat or contact pipes with harmful substances, such as acetone, thinner, cresol, insecticide, termite repellent, etc. Furthermore, even if above substances do not directly contact pipes, please note that when the pipe is shallowly buried, if above substances are spilled on the ground, they will penetrate the ground and erode pipes.
- In order to reduce the expansion and contraction caused by pipeline subsidence or temperature changes, take appropriate measures as needed, for example: install flexible pipes in appropriate places.
- Vinyl adhesive should be applied evenly and uniformly on the adhesive surfaces of cleaned pipes and their accessories; then, please adhere quickly and maintain the insertion force until the specified time; next, please wipe off vinyl adhesive out of pipes after bonding them. Last, please take measures such as ventilation to expel the vinyl adhesive vapor in pipes during the construction. Therefore, it is necessary to choose suitable pipes to match relative accessories.

3 PVC-U管規格 Specification of PVC-U Pipe

(三) PVC-U電線導管 PVC-U Pipe for Electric Conduit Use (CNS 1302)

* E 管 TYPE E

單位 Unit : mm

標稱管徑 Nominal Pipe Size		外徑及 許可差 Outside Diameter and Tolerance	厚度 Wall Thickness		近似內徑 (參考) Approx. Inside Diameter	質量 (參考) Approx. Weight (kg/m)	長度 許可差 Length Toerance	長度 Length (m)
			最小 Minimum	許可差 Tolerance				
13	3/8"	18 ± 0.2	1.8	+ 0.4	14	0.144	標示值 +30 -10	4m
16	1/2"	22 ± 0.2	1.8	+ 0.4	18	0.180		4m
20	3/4"	26 ± 0.2	1.8	+ 0.4	22	0.216		4m
28	1"	34 ± 0.3	2.7	+ 0.6	28	0.420		4m
35	1 1/4"	42 ± 0.3	3.1	+ 0.8	35	0.608		4m
41	1 1/2"	48 ± 0.4	3.1	+ 0.8	41	0.702		4m
52	2"	60 ± 0.5	3.6	+ 0.8	52	1.010		4m
65	2 1/2"	76 ± 0.5	4.1	+ 0.8	67	1.450		4m
80	3"	89 ± 0.5	5.1	+ 0.8	78	2.070		4m
100	4"	114 ± 0.6	6.6	+ 1.0	100	3.420		5m
125	5"	140 ± 0.8	7.0	+ 1.0	125	4.490		5m
150	6"	165 ± 1.0	8.5	+ 1.4	148	6.460		6m
200	8"	216 ± 1.3	10.5	+ 1.4	194	10.340		6m

註/NOTE :

1. 外徑係指任意互相垂直兩外徑之算術平均值。
2. 管材長度可由買賣雙方協議。

1. Average O.D refers to the arithmetic arithmetic mean value of any two given O.D at the right angle to each other.
2. Pipe length can be determined by the buyer and seller agreement.

* ES-1管 TYPE ES-1

單位 Unit : mm

標稱管徑 Nominal Pipe Size		外徑及 許可差 Outside Diameter and Tolerance	厚度 Wall Thickness		近似內徑 (參考) Approx. Inside Diameter	質量 (參考) Approx. Weight (kg/m)	長度 許可差 Length Toerance	長度 Length (m)
			最小 Minimum	許可差 Tolerance				
80	3"	89 ± 0.5	2.7	+ 0.6	83	1.160	標示值 +30 -10	4m
100	4"	114 ± 0.6	3.6	+ 0.8	106	1.980		5m
125	5"	140 ± 0.8	4.1	+ 0.8	131	2.750		5m
150	6"	165 ± 1.0	5.1	+ 0.8	154	3.960		5m

註/NOTE :

1. 外徑係指任意互相垂直兩外徑之算術平均值。
2. 管材長度可由買賣雙方協議。

1. Average O.D refers to the arithmetic arithmetic mean value of any two given O.D at the right angle to each other.
2. Pipe length can be determined by the buyer and seller agreement.

* 使用時注意事項 / Precautions :

1. 管在屋外儲存時應避免日光直射，在熱氣可流通的方式下覆蓋帆布等措施。
 2. 不得對管直接切螺紋。
 3. 不得有對其材質有不良影響之物質，例如丙酮、稀釋劑、雜酚油、殺蟲劑、白蟻驅除劑等進行噴射、塗布。
1. The pipes should be stored outdoors to avoid direct sunlight, in the hot air circulation can be covered under the canvas and other measures.
 2. Do not thread the pipe directly on the pipe.
 3. The material that adversely affects the pipes, Such as acetone, diluents, creosote, insecticides, termite repellents etc., should not sprayed and applied on the pipes.

3 PVC-U管規格 Specification of PVC-U Pipe

(四) 耐衝擊PVC-U管 PVC-U Pipe for High-Impact Use (CNS 14345)

單位 Unit : mm

標稱管徑 Nominal Pipe Size		外徑 Outside Diameter			厚度 Wall Thickness		近似內徑 (參考) Approx. Inside Diameter	質量 (參考) Approx. Weight (kg/m)	
		基準尺度 Reference Diameter	最大、最小 外徑之許可差 ^(a) Tolerance of max. and min outside diameter ^(a)	平均外徑之 許可差 ^(b) Tolerance of mean outside diameter ^(b)	最小 Minimum	許可差 Tolerance			
16	½"	22	± 0.2	± 0.2	2.7	+ 0.6	16	0.251	
20	¾"	26					20	0.304	
25	1"W	32					25	0.439	
30	1¼"W	38	± 0.3		31	0.531			
40	1½"	48			40	0.774			
50	2"	60	± 0.4		± 0.5	4.1	+ 0.8	51	1.099
65	2½"	76	67			1.415			
80	3"	89	77			2.156			
100	4"	114	± 0.6		± 0.3	6.6	+ 1.0	100	3.338
125	5"	140	± 0.8			7.5		+ 1.2	124
150	6"	165	± 1.0	9.0		146			6.562
200	8"	216	± 1.3	± 0.7	10.5	+ 1.4	194	10.089	
250	10"	267	± 1.6	± 0.9	13.0	+ 1.8	239	15.473	
300	12"	318	± 1.9	± 1.0	15.5	+ 2.2	285	22.005	
350	14"	370	± 2.2	± 1.2	18.0	+ 2.6	332	29.770	
400	16"	420	± 2.6	± 1.3	20.5	+ 3.0	376	38.511	
450	18"	470	± 3.0	± 1.5	22.9	+ 3.4	421	48.170	
500	20"	520	± 3.5	± 1.6	25.3	+ 3.8	466	58.930	
600	24"	630	± 4.0	± 3.2	30.7	+ 4.0	565	85.860	

註/NOTE:

- (a)最大、最小外徑之許可差係指在任意截面之外徑測定值最大值及最小值(最大、最小外徑)與基準尺度之差。
 - 耐衝擊活套管之尺度規格與自來水用相同。
 - 耐衝擊管為藍黑系顏色。
 - 其他顏色可經由協議後予以訂購。
 - 管材長度可由買賣雙方協議。
 - 標稱管徑450、500、600其承口尺度需經當事人間協議。
- (a)The tolerance of maximum and minimum diameter means the difference between the measured maximum and minimum values of outside diameter in a randomly picked cross-section (maximum and minimum diameter) and the reference dimension.
 - The pipe sizes and specification of ring-seal type for High-Impact are same with the ring-seal type for Drinking water's.
 - PVC-U pipe for High-Impact is dark black-blue color.
 - The other colors could be produced by deal with customers.
 - Pipe length can be determined by the buyer and seller agreement.
 - Nominal Pipe Size 450、500、600 with solvent cement socket can be determined by the buyer and seller agreement.

3 PVC-U管規格 Specification of PVC-U Pipe

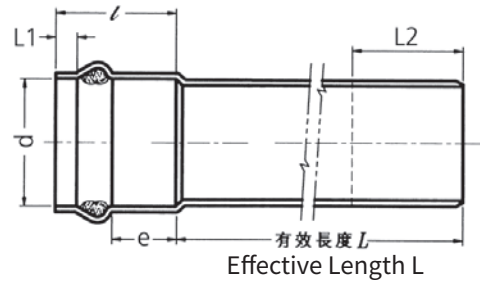

* 活套管(自來水用) Ring-Seal Type for Water Supply

單位 Unit : mm

標稱管徑 Nominal Pipe Size	平均內徑 最小值(d) (min) Mean Inside Diameter	有效插入長度 最小值(e) (min) Insert Effective Length	管承口長度 最小值(ℓ) (min) Socket Length	雄管插入長度 L2(約) Insert Length of Male Adapter	有效長度 L
40	1½"	48.3	57	110	4m
50	2"	60.3	58	115	4m~7m
65	2½"	76.4	60	125	4m~7m
80	3"	89.5	61	130	4m~7m
100	4"	114.5	64	145	5m~7m
125	5"	140.6	67	150	5m~7m
150	6"	165.7	70	165	6m~7m
200	8"	216.9	76	190	6m~7m
250	10"	268.1	82	210	6m~7m
300	12"	319.3	88	235	6m~7m
350	14"	371.5	89	245	6m~7m
400	16"	421.7	91	265	6m~7m
450	18"	471.9	94	290	6m~7m
500	20"	522.1	96	305	6m~7m
600	24"	633.8	102	355	6m~7m

註/Note:

- 200mm(8")以上為活套增厚管,其承口部分之厚度不得小於直管之厚度。
- 管材長度可由買賣雙方協議。
- Above 200mm(8") is the ring-seal type for drinking water, and its thickness of socket must be thicker than thickness of PVC-U pipe.
- Pipe length can be determined by the buyer and seller agreement.

* 長型活套管 (A型) Ring-Seal Type A for Drinking Water Supply

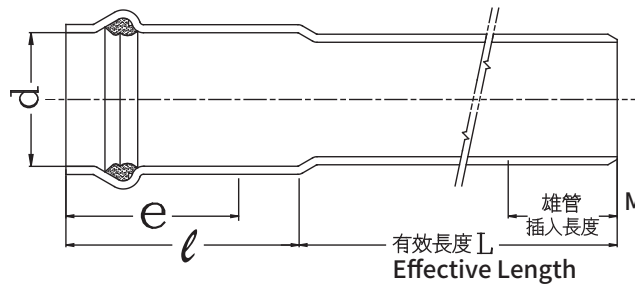

d : 內徑 Inside Diameter
e : 插入長度 Insert Length
 ℓ : 承口長度 Socket Length

單位 Unit : mm

標稱管徑 Nominal Pipe Size	平均內徑 最小值(d)(min) Mean Inside Diameter	有效插入長度 最小值(e)(min) Insert Effective Length	管承口長度 最小值(ℓ)(min) Socket Length	承口厚度 Wall Thickness of Socket		有效長度 L Effective Length
				最小 Minimum	許可差 Tolerance	
40	1½"	48.2	215	3.6		4m
50	2"	60.3	220	4.1	+0.8	4m~7m
65	2½"	76.5	220	5.5		4m~7m
80	3"	89.5	220	6.6	+1.0	4m~7m
100	4"	114.6	235	7.5		5m~7m
125	5"	140.6	245	9.0	+1.2	5m~7m
150	6"	165.8	250	10.5		6m~7m
200	8"	217.0	270	13.0	+1.4	6m~7m
250	10"	268.1	290	15.5	+1.8	6m~7m
300	12"	319.4	310	18.0	+2.2	6m~7m
350	14"	371.6	330	20.5	+2.6	6m~7m
400	16"	422.0	350		+3.0	6m~7m

註/NOTE :

- 管材長度可由買賣雙方協議。
Pipe length can be determined by the buyer and seller agreement.

3 PVC-U管規格 Specification of PVC-U Pipe

★ 可撓性活套管(B型) Ring-Seal Type B for Water Supply

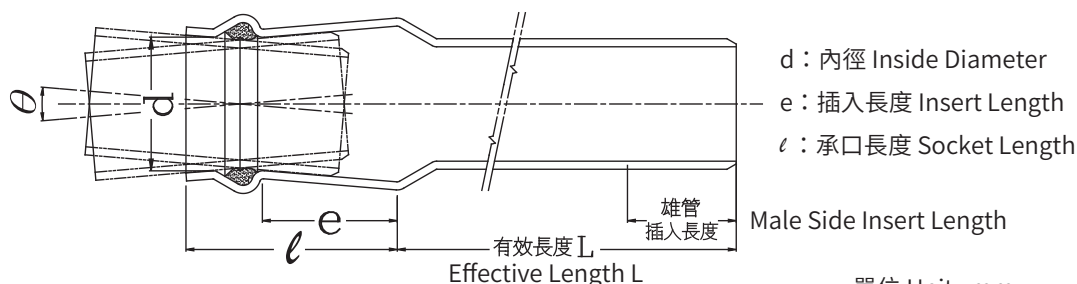

單位 Unit : mm

標稱管徑 Nominal Pipe Size	平均內徑 最小值(d) (min) Mean Inside Diameter	有效插入長度 最小值(e) (min) Insert Effective Length	管承口長度 最小值(ℓ) (min) Socket Length	承口厚度 Wall Thickness of Socket		有效長度 L Effective Length	
				最小 Minimum	許可差 Tolerance		
40	1½"	48.3	44	105	3.6	+0.8	4m
50	2"	60.3	50	125	4.1		4m~7m
65	2½"	76.4	55	135	5.5		4m~7m
80	3"	89.5	60	145	6.6	+1.0	4m~7m
100	4"	114.5	80	160	7.5	+1.2	5m~7m
125	5"	140.6	90	175	9.0		5m~7m
150	6"	165.7	100	200	10.5	+1.4	6m~7m
200	8"	216.9	115	235	13.0	+1.8	6m~7m
250	10"	268.1	145	280	15.5	+2.2	6m~7m
300	12"	319.3	170	320	18	+2.6	6m~7m
350	14"	371.5	200	355	20.5	+3.0	6m~7m
400	16"	421.7	230	380			6m~7m

註/NOTE :

1. 可撓性活套頭(B型)套接後雄管端之可撓度 θ : $\pm 5^\circ$ 以內。
2. 管材長度可由買賣雙方協議。
1. Ring-Seal Type B joint together, the deflection θ : Between $\pm 5^\circ$
2. Pipe length can be determined by the buyer and seller agreement.

(五) 管筏用PVC-U管 PVC-U Pipe for Raft Use (CNS 12698)

單位 Unit : mm

標稱管徑 Nominal Pipe Size		外徑及許可差 Outside Diameter and Tolerance	厚度及許可差 (mm) Wall Thickness and Tolerance	近似內徑 (參考) Approx. Inside Diameter	最大長度及 許可差 Greatest Length and Tolerance	質量(參考) Approx. Weight (kg/m)
125	5"	140 \pm 0.8	3.3 + 0.5	133	10,000	2.150
150	6"	165 \pm 1.0	3.7 + 0.7	157	11,000	2.900
200	8"	216 \pm 1.3	4.6 + 0.8	206	12,000	4.760
250	10"	267 \pm 1.6	6.6 + 1.0	253	13,000	8.210
300	12"	318 \pm 1.9	8.0 + 1.2	301	14,000	11.860
350	14"	370 \pm 2.2	9.3 + 1.5	350	15,000	16.230
400	16"	420 \pm 2.6	11.2 + 1.8	396	16,000	22.080
450	18"	470 \pm 3.0	13.1 + 2.0	442	17,000	28.790

註/NOTE :

1. 外徑係指任意互相垂直兩外徑之算術平均值。
2. 管材長度可由買賣雙方協議。
1. Average O.D refers to the arithmetic mean value of any two given O.D at the right angle to each other.
2. Pipe length can be determined by the buyer and seller agreement.

用途：適用於沿海及淡水之漁撈、養殖作業之管筏用管。

Application: Rafts for coastal fishing, freshwater fishing, and aquaculture

3 PVC-U管規格 Specification of PVC-U Pipe

(六) 鑿井用管 Well Drilling Engineering

單位 Unit : mm

標稱管徑 Nominal Pipe Size		外徑及 許可差 Outside Diameter and Tolerance	厚度及許可差 (mm) Wall Thick- ness and Tol- erance	近似內徑 (參考) Approx. Inside Diameter	重量參考 Approx. Weight (kg/m)	長度 Length (m)
150	6"	165± 0.5	9.0+1.2	146	6.701	6m
200	8"	216± 0.7	11.0+0.7	194	10.129	6m
250	10"	267± 0.9	13.0+1.5	240	15.481	6m
300	12"	318± 1.0	15.5+1.8	286	21.962	6m
350	14"	370± 1.2	18.0+2.6	333	30.407	6m
400	16"	420± 1.3	20.5+3.0	378	39.336	6m
450	18"	470± 1.5	22.9+3.4	423	49.223	6m
500	20"	520± 1.6	25.3+3.8	468	60.218	6m
600	24"	630± 3.2	30.7+4.0	567	87.746	6m

註/NOTE :

- 外徑係指任意互相垂直兩外徑之算術平均值。
- 管材長度可由買賣雙方協議。
- Average O.D refers to the arithmetic mean value of any two given O.D at the right angle to each other.
- Pipe length can be determined by the buyer and seller agreement.
- 依據經濟部水利署規劃試驗所編輯之「附冊三-地下水水井鑿井技術參考手冊」章節7.5鑿井工程因地面以下情況不能絕對控制，故工程工料之損耗或失敗無法完全避免。最常見者有下述現象：
 - (1)鑽孔：井孔崩坍彎曲，或鑽鑿特別艱難等。
 - (2)放管：接頭脫節管體陷落，管體破裂彎曲，或無法安放至預定深度等。
 - (3)填石：投填時擦坍孔壁，或架橋效應產生填充不實等。
 - (4)擴水：地層組織過於細緻久洗不清，孔壁坍塌錯亂挽救困難，或水井效率不足須延長擴水時間等。
 - (5)其他：機械故障、工具陷落、備料不足、進度滯緩、工時延誤等。
- 影響鑿井工程發生損耗或失敗之因素頗為複雜，有：地層因素、設備因素、環境因素、氣候因素、技術因素、或其他不可抗因素等。謹提供予鑿井施工業者參考。
 1. According to Chapter 7.5 of the "Appendix III-Groundwater Well Drilling Technical Reference Manual" edited by the Planning and Testing Institute of the Ministry of Economic Affairs of the Ministry of Economic Affairs, the below-ground conditions cannot be absolutely controlled for the well drilling project, so the loss or failure of engineering materials cannot be completely avoided. The most common ones have the following phenomena:
 - (1) Drilling: the hole collapses and bends, or drilling is particularly difficult.
 - (2) Pipe release: The joint is disconnected, the tube body collapses, the tube body is broken and bent, or it cannot be placed to a predetermined depth, etc.
 - (3) Rock-filling: rub the wall of the collapsed hole during casting, or the filling effect caused by the bridging effect, etc.
 - (4) Water expansion: the stratum structure is too detailed to wash for a long time, the hole wall collapses and it is difficult to save, or the efficiency of the well is insufficient to extend the water expansion time.
 - (5) Others: mechanical failure, tool fall, insufficient material preparation, slow progress, delay in working hours, etc.
 2. The factors that affect the loss or failure of the well drilling project are quite complex, including: formation factors, equipment factors, environmental factors, climatic factors, technical factors, or other force majeure factors. Above information is for reference only.

3 PVC-U管規格 Specification of PVC-U Pipe

(七) T.S. 放口管(單放) Pipe With Solvent Cement Socket (Single Socket)

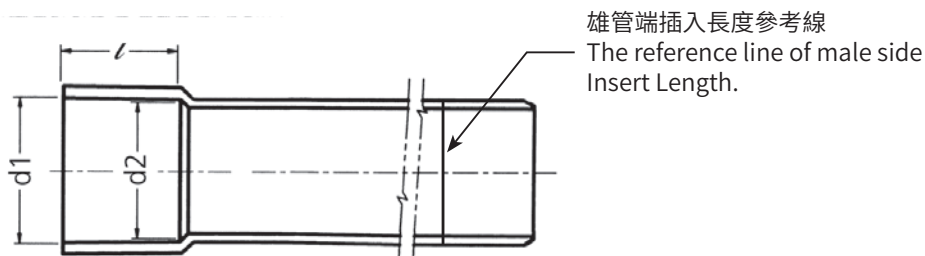

單位 Unit : mm

標稱管徑 Nominal Pipe Size		平均內徑		放口頭長度 (l) (min) 最小值
		d1(口部)	d2(根部)	
13	3/8"	18.40±0.20	17.53±0.20	26
16	1/2"	22.40±0.20	21.52±0.20	30
20	3/4"	26.45±0.20	25.42±0.20	35
25	1"W	32.55±0.25	31.37±0.25	40
30	1 1/4"W	38.60±0.25	37.31±0.25	44
40	1 1/2"	48.70±0.30	47.21±0.30	55
50	2"	60.80±0.30	59.10±0.30	63
65	2 1/2"	76.80±0.30	75.12±0.30	64
80	3"	89.60±0.30	88.30±0.30	64
100	4"	114.70±0.30	113.20±0.30	84
125	5"	140.90±0.40	139.10±0.40	104
150	6"	166.00±0.50	163.90±0.50	132
200	8"	217.90±0.80	213.90±0.80	200
250	10"	269.30±0.90	264.30±0.90	250
300	12"	320.70±1.00	314.70±1.00	300
350	14"	373.10±1.00	366.10±1.00	350
400	16"	423.60±1.20	415.60±1.20	400
450	18"	474.00±1.20	465.00±1.20	450
500	20"	524.50±1.30	514.50±1.30	500
600	24"	635.30±2.10	623.30±2.10	600

註 /NOTE :

1. VP(B 管) 適用標稱管徑 13 ~ 600, VU(A 管) 適用標稱管徑 40 ~ 700, W 管適用標稱管徑 13 ~ 600。
 2. 管材長度可由買賣雙方協議。
 3. 出廠時, 每支 TS 單放口管材之雄管端均有畫上插入長度參考線, 主要係提供管材與管材接合時參考用, 若用於管材與接頭接合時, 因接頭承口長度較短, 容易出現參考線超出接頭承口長度之情形。
1. Nominal diameter 13~600 apply for VP(B Pipe) pipes, and 40~700 apply for VU(A Pipe) pipes, and 13~600 apply for W pipes.
 2. Pipe length can be determined by the buyer and seller agreement.
 3. At the time of delivery, the male pipe end of each T.S. single-socket pipe has a drawing length reference line, which is mainly used for reference when the pipe and the pipe are joined. If the T.S. single-socket pipe is used for jointing with the fitting, the reference line will exceeding the length of the fitting's socket.

4 PVC-U管之施工法 Installation of PVC-U Pipe

(一) 施工方法 Installation of PVC-U Pipe

(1) 一次插入法 One-time Inserting Method :

適用於小口徑管之相接，其施工步驟如下：

This method is suited for connecting medium Diameter pipes. The installation process is as follows :

1. 將兩管管端，先用銼刀或尖尾小刀依30°方向削角(雌管削內角，雄管削外角)使管端尖厚剩1mm，(管厚3mm以上者，剩約1/3t)參照圖1。
2. 雌管管端加熱(120~130°C)使軟化(用噴燈或炭火直接加熱或以熱油，熱砂間接加熱均可)。
3. 雄管端外部均勻塗敷硬質膠合劑，然後插入雌管中，插入深度，小口徑者以管徑之1.2~1.5倍。
4. 兩管矯正成直線後，用濕布或冷水冷卻，並擦掉洩流於管外之膠合劑。

1. Whittle two edges of adapter with file or knife at 30 angle(whitting in-side angle of fema a adapter and outside angle of male adapter) untill edge thickness comes to about 1mm(or 1/3 thicknes if pipe thickness scover 3mm). Referring to illustration 1.
2. Heat one edge of female adapter at 120-130°C to make it soft (heat-ing with blow torch or burning charcoal direct or with out oil or hot sand indirect).
3. Smear outside edge of male acapter with adhesive averagelty andthen insert the edge into female adapter. the inserting depth is 1.2-1.5 times of pipe diameter for small diameter pipes.
4. After two adapters are connected and adjusted to alignment, coll them with cloth or cold water and wipe off the



圖1 Fig 1

(2) 二次緊密插入法 Two-time tight inserting method :

適用於中口徑之相接，其施工步驟如下：

This method is suited for connecting large diameter pipes. The installation process is as follows :

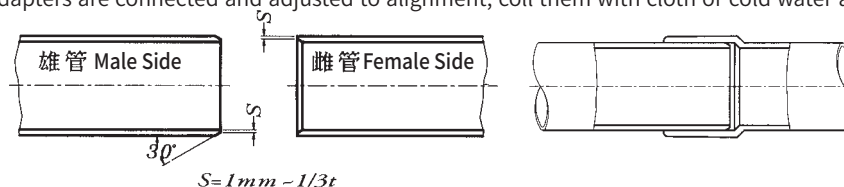
permeated adhsvie.

1. 將兩管管端依30°角度削角，雄管削外角，雌管削內角，方法與一次插入法相同，但較大口徑之削角，可先以噴燈加熱至半軟化後，用小刀切削，再用銼刀略作修整，可使施工速度加快。
2. 雌管端加熱(120~130°C)使軟化。
3. 雄管末端塗敷膠合劑前，先在管端塗以牛油等潤滑劑，插入已軟化之雌管，矯正成直線後用濕布或冷水冷卻使之定型。
4. 在連接處與管軸平行作記號，並在兩管端寫上號碼，以免配管時發生混亂。參照圖2。
5. 把雄管拔出然後將兩端之潤滑劑徹底擦拭乾淨，相接時雌雄兩端皆塗上膠合劑，順直線記號，插入定位即成。

1. Whittle edges of two adapters at 30 angle. outside angle of male adapter and inside angle of female adapter. same method as item 1 to whittle angle of large clameter pipes. first heat edges with blow torch to make it soft then whittle with knife and trim with file this can step up installation.
2. Heat female adapter edget at 120-130°C to make it soft.
3. Primor to smearing male adapter edge with adhesive. spread the edge with lubricant such as butter. and insert the lubricated edge into softened male adapter. then adjust. them to alignment. and finally coll them with wet cloth or cold water for formation.
4. Draw a line on connected edges paaraiell to pipe length direction and write figures on two edges to avoid confusion while connecting referring to illustration 2.
5. Pull out the male adapter and wipe off the lubricant semeared on two connected edges. Before connecting smear edges of both male and female adapters with adhesive. then insert and locate the adapters along the crawn line.



圖2 Fig 2

4 PVC-U管之施工法 Installation of PVC-U Pipe

(3) TS冷接法 TS unheating connection method :

本法係應用於工廠已事先加工成TS接頭之管件，或射出接頭之接合，施工簡便迅速，尤其嚴禁煙火地區之配管施工最為適宜，並可在極短時間內通水使用，(中大口徑尤為適用)，其施工步驟如下：

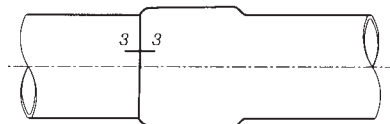
This method is applied to the connection of pre-processed TS or injection fittings it features its quick and easy installation and especially suitability in places where fire and smoking is strictly prohibited. It allows water to flow within a short time after installation. The installation process is as follows.

1. 雄管端削外角：以銼刀(粗目)削角為最常用的方法，但在大口徑之情況，因銼削速度較慢，故大口徑可先以噴燈將管端作局部加熱，使之呈半軟化狀態，再以小刀沿圓周逐次切削，至全圓周切削完妥為止，而斜面稍有不平之處，再以銼刀修整。另一方式係採用刀輪削角，但此方式乃廠內專業性之作業，工地較少採用。切削之角度須沿30~45°角，其預留之尖端厚度為1/3t (如圖3所示)。
2. 施工前，應測量TS單放口或接頭承口的承插深度，並在雄管端標示此承插深度。
3. 每支TS單放口管出廠前，雄管端均有畫上一條黑色參考線，供施工時承插之參考，此黑線並非承插長度，承插時應儘量往內插到緊為原則。
4. 管材在工地有裁切過，雄管端之承插長度參考線應事先以油性色筆作記號。
5. 大口徑管應使用高粘度硬質膠合劑，防止垂流。
6. 接頭承口內壁及管端外壁插入範圍，先以酒精或乾布擦拭乾淨，然後雌雄管內外側插入範圍各塗上適量的硬質膠合劑，尤其上緣處在承插前需再補足硬質膠合劑。若因氣溫高，膠合劑乾的速度快，應即補充膠合劑，待部份溶劑揮發而膠著性增強時，則一口氣用力插入，插到緊為原則，小管子可旋轉90°(大口徑管不必旋轉)，使膠合劑之分佈更為均勻。中、大口徑管子插入後，管端可墊以厚木板或木角材，用木槌擊入或以鐵棒撬入，使插接更為密著。
7. 管線完成TS冷接法施工後，膠合強固期間不能移動，待膠合劑完全乾涸後即可通水、試水。

1. The male side of PVC pipe, cutting 30° to 45° angle by the wide file or cutting wheel, and the thickness of pipe end face is about 1/3t.
2. The depth of insertion of the TS singled hole or fitting hole should be measured and marked in the male side of PVC-U pipe before construction.
3. Each PVC pipe with taper socket, the male side are painted a black line, the length of socket for reference.
4. IF PVC pipe have cut off, please painted a reference line of the length of socket.
5. To avoid leakage, it is suggested that large size of PVC-U pipe be glued with high viscosity of PVC adhesive.
6. First, please clean the inside of the fitting, socket, and the male side of PVC-U pipe with alcohol or dry cloth; then, please smear PVC adhesive on them; last, please insert the male side of PVC-U pipe into the fitting or socket tightly. If temperature is too high or PVC adhesive dries too fast, it is suggested that PVC adhesive be supplied quickly. Then, please insert PVC-U pipes tightly until PVC adhesive is volatile and its adhesion is reinforced. In addition, small size of PVC-U pipe can be rotated (90°) so that PVC adhesive can be distributed more uniformly. As for medium or large size of PVC-U pipe, both sides of PVC-U pipes can be padded with thick wooden plate or beam when being inserted, and please use wooden hammer or iron bar to make joints of PVC-U pipes tight and stable.
7. After completed the TS unheating connection, please don't move the piping line during the curing time, until the rigid PVC adhesive is completely dry. Then allow water to flow.



圖3 Fig 3

4 PVC-U管之施工法 Installation of PVC-U Pipe

(4) 斜度環平口接法 Taper ring connection method :

PVC-U管需要使用平口時可如圖4所示，使用金屬斜口法蘭(Taper Flange)與斜度環做成平口，以迫緊(Packing)及螺栓連結。其施工法如下：

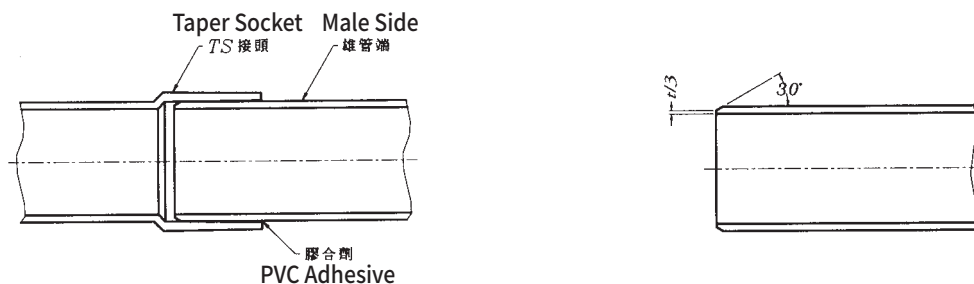
If PVC-U pipe requires to use solvent. belling refer to illustration 4 to take metal taper flange and taper ring to make and belling solvent then connect them with packing and screw. The installation process is as follows.

1. 將管端內壁及斜度環之斜面用工業酒精擦拭清潔。
 2. 管端加熱使之軟化，一面在斜度環之斜面塗以膠合劑。
 3. 先將斜口法蘭(Taper Flange)套入後再將斜度環套入已軟化之管端。此時應注意使斜度環略突出管口外，而斜度環之平面與管軸垂直，然後用水冷卻定型。
 4. PVC平口與PVC平口相接，或PVC平口與凡而(Valve)相接，平口接合凡而均須墊以迫緊(Packing)以螺絲連結之。
1. Wipe clear inside of pipe edge and tilt side of taper ring with alcohol.
 2. Heat pipe edge to make it soft. At the same time, smear adhesive on tilt side of taper ring.
 3. Put titling taper flange first and then titling ring into softened pipe edge. At this moment, have to make sure taper ring sticks out of pipe edge and surface of taper ring stays vertical to pipe axis. Then, cool them with cold water for formation.
 4. Connect PVC solvent belling together or PVC solvent belling and valve together. The latter connection method require to cushion a packing and screw.



圖4 Fig 4

(5) 法蘭平口接法 Installation of Flange :

1. PVC管外緣沿30~45度角削角，100mm(4")以下，可用銼刀、銼削。125mm(5")以上可先以噴燈略予加熱半軟後以小刀切削，再以銼刀整修。
2. PVC管插入部份之外緣及法蘭接頭承口內壁，擦拭乾淨後，分別塗佈硬質膠合劑後用力套入，125mm(5")以上之規格，套入後可墊以厚木板或木角材鎚擊之，加強密著效果。
3. 溢出之膠合劑，用布加以拭淨。
4. 法蘭接頭與PVC管接合後，其法蘭部再與凡而之法蘭螺孔對準中間墊以迫緊(Packing)，以螺絲連墊圈接合之。螺絲之鎖緊，應對角相互進行，以達均勻密接之效果。

1. The outside rim of PVC pipe should be whittled with a knife at a 30 angle. For pipes under 100mm (4") trim with a file: above 125mm (5") heat first with a blow torch, whittle and then finalize by trimming with a file.
2. Sweep and clean the inside wall of the flange socket and the outside rim of the PVC pipe to be inserted in. then smear rigid adhesive and insert toiciby. For specification above 125mm (5") a thick board or wodden angle material may be placed under.
3. Wipe the overflow adhesive with a piece of cloth.
4. After flange and PVC pipe are connected, aim the flange bolt holes of valve at the flange part with packing cushioned in between, and then bolt the holts to couple them. While operating, diagonally screwing is preferred so that even and close effect may be achieved.

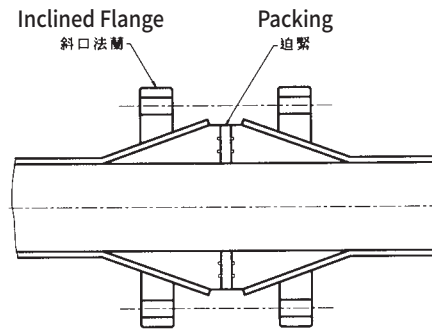

圖5 Fig 5

4 PVC-U管之施工法 Installation of PVC-U Pipe

(6) 活套管之施工法 Installation of ring-seal type pipe :

1. 雄管端削外角，外角係沿20角度削角，其預留之尖端厚度約1/4t~1/3t。（每支管之削角，出廠前已削妥，如再切斷，須在工地自行削20°外角）。
 2. 自活套頭內取出套環（橡膠Ring）擦拭乾淨，另活套溝槽內亦予擦拭乾淨。然後活套Ring再予套回（注意活套Ring方向不可裝反）。
 3. 雄管端上標註插入長度記號（一般出廠前已標示完成）。
 4. 套環內面與雄管管端插入部份塗敷潤滑劑，特別注意，不可在活套溝槽潤滑，易導致活套溝槽佈滿潤滑液，失去摩擦力，當雌雄管套接時，活套Ring移位而造成漏水，如圖示。
 5. 雌雄管套接（小口徑用人力插接，中口徑管端墊上厚木板或木角材，以木槌槌入，大口徑須用拉緊器插接），套接後所留之縫隙，標稱管徑50以下約10mm，65~100約15mm，125~150約20mm，200以上為25mm。
1. Cut the exterior angle of a male pipe by 20 degree and leave 1/4t~1/3t thickness at its tip. (Each pipe has the angle of chamfer before it goes to the market. If cutting is still needed, one has to pare the pipe by 20 degree at the construction site.)
 2. Take out the ring (rubber ring) from the pipe and clean it. Clean the inside of the pipe and mount the ring back (Notice : Ring shall be installed correctly)
 3. Mark the insertion length at the end of the male pipe (This step usually is done by manufacturer)
 4. Lubricate the inner ring and the insertion section of the male pipe. Notice: No lubricant on the ring trough; otherwise it may cause loss of friction of the ring trough when the trough gets lubricated. Also, when male and female pipes combine, the rubber ring may be displaced and causes leaking. See Figure 6.
 5. Combination of male and female pipes (In inserting the two, hands are for small sizes, a wooden mallet for middle sizes after the pipes are on a plank or a wooden block, and a puller for large sizes.) The gap after the insertion : about 10mm for smaller than 50; 15mm for 65~100; 20mm for 125~150; 25mm for larger than 200.

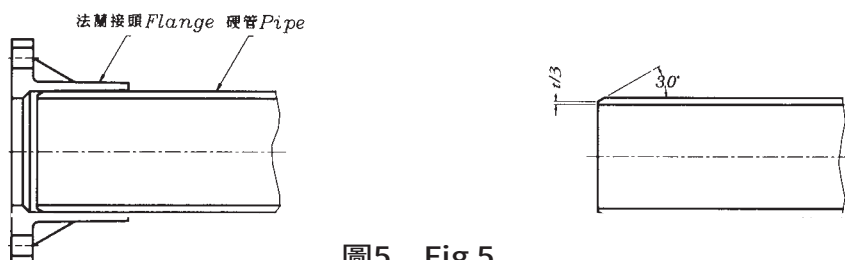

圖6 Fig 6



4 PVC-U管之施工法 Installation of PVC-U Pipe

(二) PVC-U管施工應注意事項

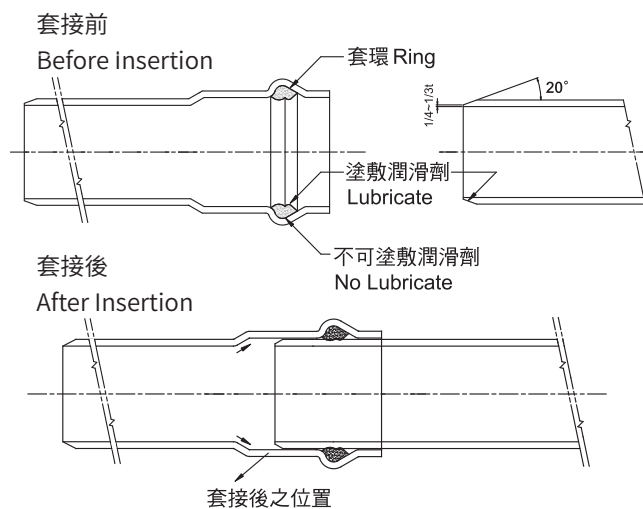
- 1.大樓建築物樓板打混凝土之前，自來水管線須依「建築技術規則」建築設備編第二章-給水排水系統及衛生設備第28條之規定做水壓試驗。試驗壓力不得低於10kgf/cm²或最高使用壓力之1.5倍，並應保持1小時如無漏水始可打混凝土，上述之水壓試驗，一般均每層分別進行。
- 2.活套管試水壓時，管線須予蓋土，如環境許可時，可僅留活套頭部份不蓋土，試水前須蓋土的目的，主要為防止活套頭試水壓時之脫開，如在市區因交通流量大，一般可全部蓋土後試水壓。
- 3.管線施工後須分段試水壓，每段長度約500~1000m，試靜水壓力為10kgf/cm²或使用壓力之1.5倍，並維持1小時並勘察是否有漏水現象。
- 4.管線較高之位置與管端，應裝設排氣閥。
- 5.管線埋設須先填砂，厚度最小10cm，管子配管後，再填砂10~30cm，使管子不致與石頭直接接觸。
- 6.大樓樓板的電氣配管以直線配管為原則，如需要彎曲時，一個彎曲角度應在90°以內，且一區間（兩接線盒間）的管線彎曲角度，合計不得超過270°，且其配線長度，不得超過30m。
- 7.電氣用管與接線盒，裝配後於打混凝土時應防止受到破壞或損傷，如有破損應即修復，以免混凝土之阻塞影響往後的拉線工作。
- 8.樓板內的埋設配管，一個交叉點的管子，應為2支以下，不得同一位置有3支管子相交叉。
- 9.樓板打混凝土作業中，水電工作人員應常駐於工地，以便處理配管上之突發事件。
- 10.PVC-U膠合劑塗敷要適量，禁止使用過量而造成PVC-U管、接頭軟化、膨脹或破裂之異常。
- 11.大樓樓板、樑柱之混凝土應注意其固化劑添加量，避免混凝土固化時大量放熱溫度過高使PVC-U管發生變形、凹陷等異常。
- 12.PVC-U管埋設於大樓樓板、樑柱時，須依「行政院公共工程委員會施工綱要規範」、「經濟部水利署施工規範」第03310章-結構用混凝土之規定正確施工。結構混凝土施工時，為防止PVC管發生過熱造成變形、凹陷等異常現象，施工應注意下列事項：
 - (1)炎熱天候為免產生混凝土澆置時與澆置後數天內較高之混凝土溫度，導致PVC-U管軟化凹陷，應採取下列操作：
 - A.周圍溫度超過32°C以上時，應於澆置混凝土前，將模板及鋼筋等以水或其他方式適當降溫。
 - B.為避免澆置後混凝土溫度高於32°C時，應採取下列措施保護已澆置之混凝土：
 - a.以適當方式遮蔽防止混凝土直接受到日曬。
 - b.採用冷水噴灑或以溼潤之粗麻布或粗棉墊覆蓋，使模板保持潮濕。
 - (2)預拌混凝土之品質應符合CNS 3090「預拌混凝土」國家標準之規定。例如：
 - A.預拌混凝土自水加入水泥與粒料中起至運送到工地並卸料完畢止，必須在1.5小時以內完成。在天氣炎熱，或有混凝土早凝之情況時，買方可指定此運送時間少於1.5小時。
 - B.當使用預熱粒料、熱水，或二者同時採用以產製混凝土時，在製造或運送途中最高溫度不得大於32°C。
 - (3)管道之孔洞應以易於取出之材料暫時填塞，以防止混凝土水泥漿滲入。
 - (4)澆置混凝土應注意PVC-U管有無移位或變形，倘有此現象，應暫停澆置，待校正加固後再繼續澆置。
 - (5)應避免搗實過度，引起埋設PVC-U管位移、凹陷、變形。
 - (6)混凝土澆置15分鐘內，以振動器振動時不可觸及模板及鋼筋，以避免PVC-U管發生位移。

4 PVC-U管之施工法 Installation of PVC-U Pipe

13. PVC伸縮接頭作為搶修接頭的施工方法如下：

- (1) 關閉上游的制水閥，加以斷水，並挖掘破損之範圍，挖掘之範圍要長些，以利管材抬高並套入伸縮接頭之零件。
- (2) 將破損之PVC-U管切除。
- (3) 實際PVC-U管材破損之搶修施工步驟如下圖示：

(A) 切除破損之PVC管材/ Excision of damaged PVC pipe:

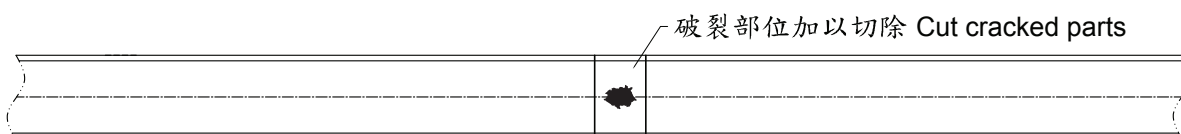

(B) 管端裁切方正、去毛刺並倒角/ Cut pipe square. Deburr and bevel:

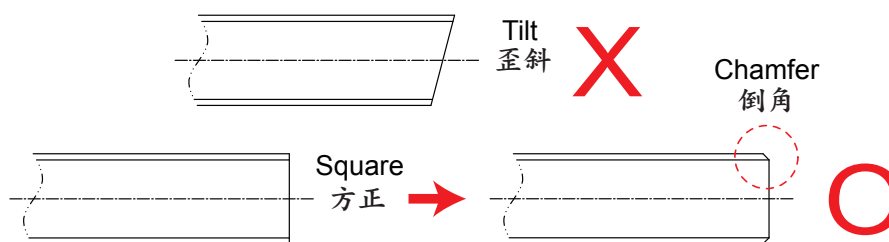

(C) 管材抬高並套入伸縮接頭的相關配件/

Accessories for pipe lifting and fitting into the PVC compression coupling:

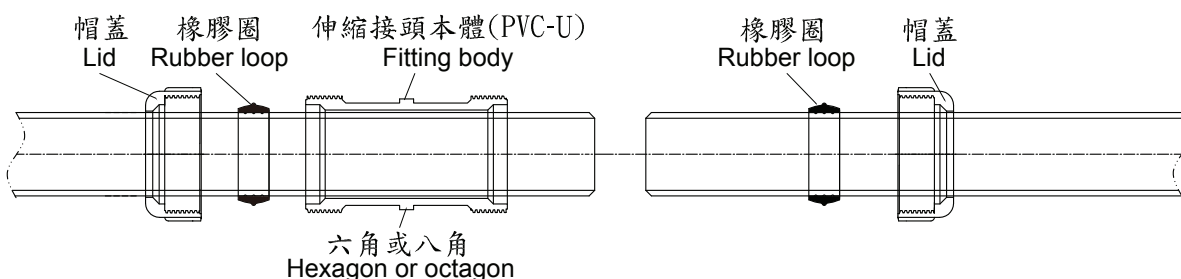

(D) 搶修後之情形/ After the repair is completed:

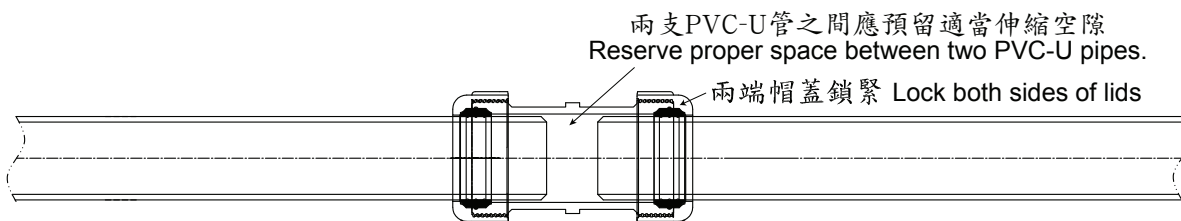

帽蓋與本體鎖緊至滿牙即可，不要過度旋緊
Lock the lid and body of the fitting tightly until there is no gap.

4 PVC-U管之施工法 Installation of PVC-U Pipe

(二) Notice Items of PVC-U Piping Instructions

1. Before concreting the floor, run water pressure test on the tape water pipe line according to Article 28, Chapter II, "Construction Technical Rules" with testing water pressure retained for one (1) hour at not lower than $10\text{kg}/\text{cm}^2$, nor higher than 1.5 times of the working pressure. Start concreting only when no leakage is observed. Usually, this test is separately run by floor.
2. Earth coverage over the pipe line is required on testing the water pressure of spigot pipe, which however may be left bare only the connecting parts if working environment permits. The purpose of earth coverage before the test is mainly to prevent the spigot from escaping during the test to be run in where heavy traffic flow occurs, such as in the downtown area.
3. Run the water pressure test by section for approximately every 500~1000m on pipe line completed. At the testing hydrostatic pressure retained for one (1) hour at not lower than $10\text{kg}/\text{cm}^2$, nor higher than 15 times of the working pressure. Observe for any leakage.
4. Provide vent valve to the pipe line at the pipe end or at where with higher elevation.
5. Sand filling with layer thickness not less than 10cm is required before the embedment of pipe line. Do not cause the pipe to contact directly with any stone.
6. Linear allocation governs the pipe for electric conduit on the building floor. If bending is required, the bend angle shall not be larger than 90° and not larger than 270° in total in one area (i.e. between two wiring cases). The wiring length shall not be larger than 30m.
7. Prevent the assembled pipe for electric conduit use and wiring cases from being destructed or damaged by concreting. Repair any damage immediately to avoid affecting the subsequent wire pulling by clog of concrete.
8. Number of pipe at intersection embedded in the floor shall not be larger than two as illustrated below. Three or more pipes at the same intersection is not allowed.
9. Civil utilities technician shall be always available on site during the operation of concreting in case of any incident to the piping work.
10. Don't apply the vinyl adhesive too much between PVC-U pipe and fitting, thus avoid the soften, expansion, cracked occurred by PVC-U pipe and fitting.
11. Put the required amount of cement hardener into the concrete, to avoid the curing heat softening, transforming the PVC-U pipe during concreting the floor, wall, column.
12. When PVC-U pipe is embedded in the floor slabs, columns and beams of a building, follow the proper concrete construction standards by following the requirements in The Practice of Construction Outline, Public Engineering Committee of Executive Yuan and Chapter 03310—Concrete for Structures in The Practice of Construction, Water Resources Department, Ministry of Economy. In construction with structural concrete, note the following items during the construction to avoid the deformation, sinking and other anomalies caused by overheating of PVC-U pipe:
 - (1) During hot weather, the following operations should be implemented in order to prevent sinking of PVC-U pipe due to softening when the temperature of concrete is too high in the few days after pouring:
 - A.** When the ambient temperature exceeds 32°C , implement proper cooling for the mold plate and rebar, etc. by water or other appropriate methods several days before pouring the concrete.
 - B.** To prevent the concrete pouring temperature exceeding 32°C , the following measures should be taken to protect the poured concrete.
 - a. Properly cover the concrete to prevent direct sun exposure.
 - b. Spray cold water or cover with moist burlap sacks or thick pads to keep the mold plate moist.

4 PVC-U管之施工法 Installation of PVC-U Pipe

(2)The quality of ready-mixed concrete should be in compliance with the requirements of CNS 3090 "Pre-blended Concrete". For example,

A.The process of adding water to the ready-mixed concrete and pellets and transporting to the construction site must be completed within 1.5 hours. In hot weather or in case of early setting of the concrete, the buyer can specify that the delivery time should be less than 1.5 hours.

B.While using the pre-heated pellets, hot water, or both at the same time for the fabrication of concrete, the maximum temperature for fabrication or transportation should not exceed 32°C.

(3)The pipe hole shall be temporarily filled with easily removable material to prevent the infiltration of concrete mortar.

(4)While pouring the concrete, it is necessary to pay attention to the PVC-U pipe in case of displacement or deformation. If this happens, the pouring should be suspended to correct the situation before continuing to pour.

(5)It is necessary to prevent excessive tamping caused by displacement, sinking and deformation of the PVC-U pipe.

(6)Within 15 minutes of pouring concrete, ensure not to touch the mold plate and rebar while the vibrator is in operation to prevent shifting of the PVC-U pipe.

13.Flexible PVC fitting is applicable to high-pressure pipeline (small or medium size) with following characteristics:

(1)Compression fitting, which is easy for construction and loading without weather impact, features superb compression and water pressure resistance.

(2)Compression fitting, not only used for underground pipeline but also suitable for above-ground pipeline, needs to be fixed tightly to avoid sliding.

(3)It is suggested that lid and body of compression fitting be locked properly.

(4)Compression fitting is not only able to absorb piping's expansion resulted from thermal expansion and contraction but able to be used for fixing cracked pipeline.

Followings are methods of construction for flexible PVC fitting used for fixing cracked pipeline:

A. Please shut off upstream valves to cut off water and dig damaged parts of pipeline. (Please use one compression fitting to fix slightly damaged parts of pipeline; moreover, please dig damaged parts of pipeline deeply and widely so that PVC-U pipes are feasible to be elevated and fitted into compression fittings).

B. Please cut damaged PVC-U pipes.

C. Followings are steps of construction for fixing damaged PVC-U pipes:



4 PVC-U管之施工法 Installation of PVC-U Pipe

14.大口徑PVC管於露出配管設計等應注意下列事項：

(1)PVC管支撐座，應由“線”接觸面，改為“面”接觸面，使PVC管重量分散，避免應力集中，確保長期使用。

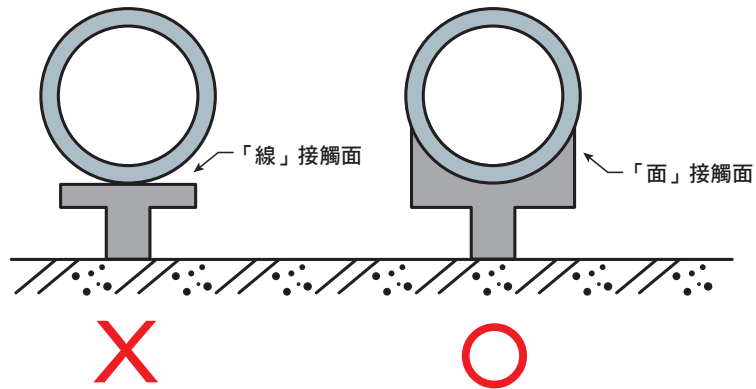

(2)活套管露出配管時，應固定住活套頭。

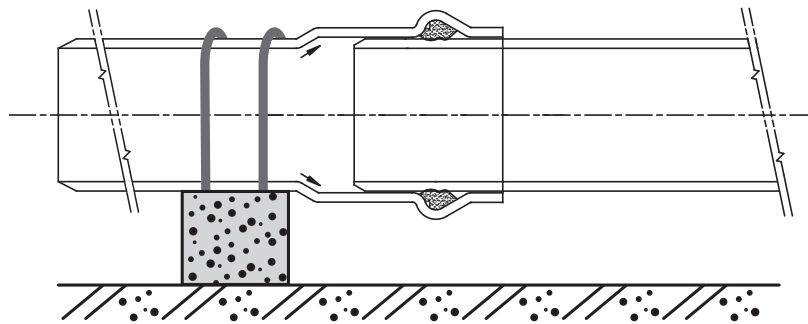

(3)管線轉向處、末端等，應增設水泥固定座(或其他方式)，避免輸水量大時產生管線偏移。

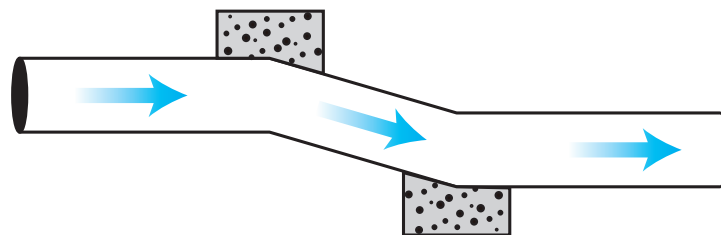

(4)管線應安裝自動排氣閥，防止管內積存空氣產生水錘。

4 PVC-U管之施工法 Installation of PVC-U Pipe

14. Cautions of PVC-U piping (large size)

- (1) To avoid concentrative strength and assure long-term life of the pipeline, the contact surface of the support base of PVC-U pipe should be changed from "line" into "plane"

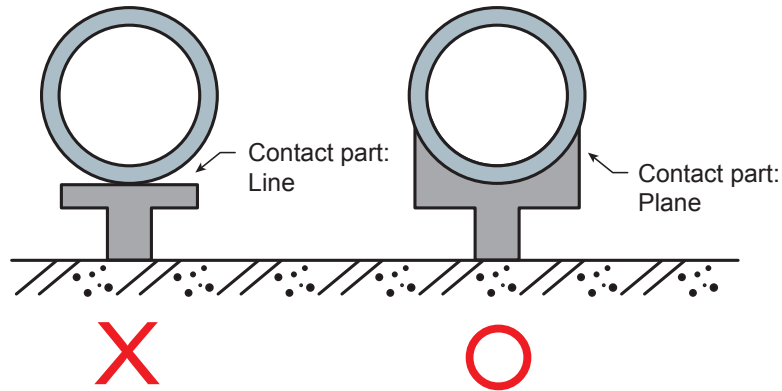

- (2) The head loop should be fixed tightly when the pipe loop is out of the pipeline.

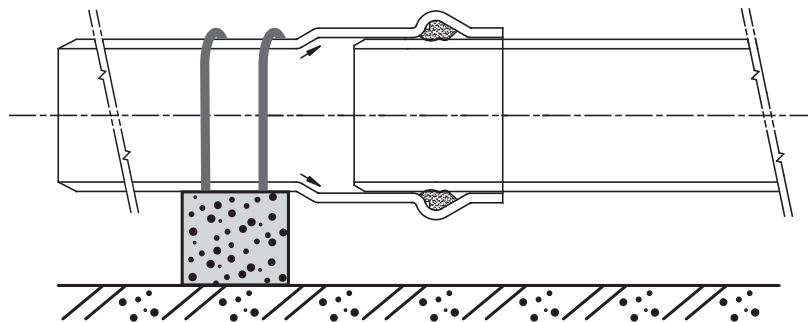

- (3) To prevent the pipeline from shifting when lots of water are transferred, it is suggested that fixation of cement be added in the turning point or the end of the pipeline.

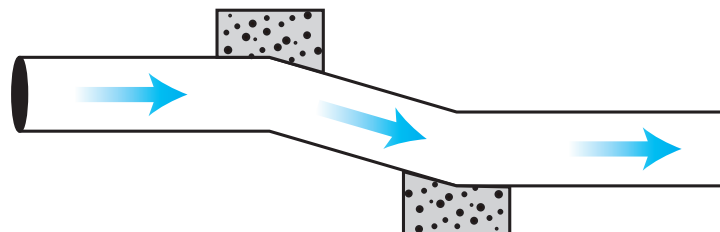

- (4) The exhaust valve should be installed in the pipeline to prevent the inside of the pipeline from water hammer.

5 自來水用接頭規格

Specification of PVC-U Fittings for Water Supply

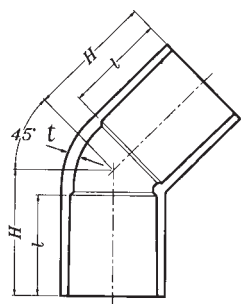

45° WL 型接頭 45° Elbow

單位：mm

規格 Size		<i>t</i>	<i>l</i>	<i>H</i>
16	½"	3.5	30	38
20	¾"	3.5	35	44
25	1"W	4.0	40	51
30	1¼"W	4.0	44	56
40	1½"	4.5	55	69
50	2"	5.0	63	80
65	2½"	6.6	61	83
80	3"	8.0	64	97
100	4"	10.0	84	122
125	5"	11.0	104	149
150	6"	13.0	132	184
200	8"	15.0	164	224

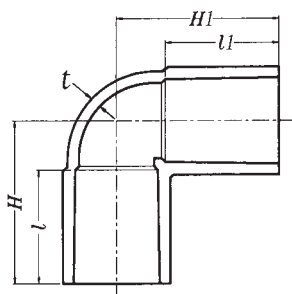

90° WL 型接頭 90° Elbow

單位：mm

規格 Size		<i>t</i>	<i>l</i>	<i>H</i>
13	⅜"	3.0	26	36
16	½"	3.5	30	43
20	¾"	3.5	35	50
25	1"W	4.0	40	58
30	1¼"W	4.0	44	65
40	1½"	4.5	55	82
50	2"	5.0	63	96
65	2½"	6.6	61	110
80	3"	8.0	64	120
100	4"	10.0	84	153
125	5"	11.0	104	188
150	6"	13.0	132	230
200	8"	15.0	164	288

5

自來水用接頭規格

Specification of PVC-U Fittings for Water Supply

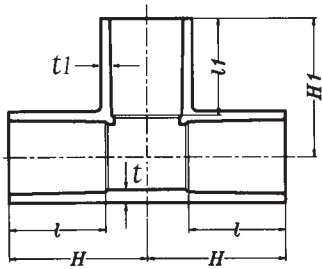

WT型同徑接頭 Tee

單位 : mm

規格	Size	t	l	H	H1
13	3/8"	3.0	26	26	36
16	1/2"	3.5	30	30	43
20	3/4"	3.5	35	35	50
25	1"W	4.0	40	40	58
30	1 1/4"W	4.0	44	44	65
40	1 1/2"	4.5	55	55	82
50	2"	5.0	63	63	96
65	2 1/2"	6.6	61	61	110
80	3"	8.0	64	64	120
100	4"	10.0	84	84	152
125	5"	11.0	104	104	187
150	6"	13.0	132	132	230
200	8"	15.0	164	164	287.5

WT型異徑接頭 Reducer Coupling

單位 : mm

規格	Size	t	t1	l	H	H1
16x13	1/2"x3/8"	3.5	3.0	30.0	26.0	41.0
20x13	3/4"x3/8"	3.5	3.0	35.0	26.0	46.0
20x16	3/4"x1/2"	3.5	3.5	35.0	30.0	48.0
25x13	1"Wx3/8"	4.0	3.0	40.0	26.0	51.0
25x16	1"Wx1/2"	4.0	3.5	40.0	30.0	53.0
25x20	1"Wx3/4"	4.0	3.5	40.0	35.0	55.0
30x13	1 1/4"Wx3/8"	4.0	3.0	44.0	26.0	55.0
30x16	1 1/4"Wx1/2"	4.0	3.5	44.0	30.0	57.0
30x20	1 1/4"Wx3/4"	4.0	3.5	44.0	35.0	59.0
30x25	1 1/4"Wx1"W	4.0	3.5	44.0	40.0	62.0
40x13	1 1/2"x3/8"	4.5	3.0	55.0	26.0	66.0
40x16	1 1/2"x1/2"	4.5	3.5	55.0	30.0	68.0
40x20	1 1/2"x3/4"	4.5	3.5	55.0	35.0	70.0
40x25	1 1/2"x1"W	4.5	3.5	55.0	40.0	73.0
40x30	1 1/2"x1 1/4"W	4.5	4.0	55.0	44.0	76.0
50x13	2"x3/8"	5.0	3.0	63.0	26.0	74.0
50x16	2"x1/2"	5.0	3.5	63.0	30.0	76.0
50x20	2"x3/4"	5.0	3.5	63.0	35.0	78.0
50x25	2"x1"W	5.0	4.0	63.0	40.0	81.0
50x30	2"x1 1/4"W	5.0	4.0	63.0	44.0	84.0
50x40	2"x1 1/2"	5.0	4.5	63.0	55.0	90.0
65x40	2 1/2"x1 1/2"	6.6	4.5	61.0	55.0	100.0
65x50	2 1/2"x2"	6.6	5.0	61.0	63.0	101.0
80x25	3"x1"W	8.0	4.0	64.0	40.0	93.0
80x40	3"x1 1/2"	8.0	4.5	64.0	55.0	100.0
80x50	3"x2"	8.0	5.0	64.0	63.0	105.0
80x65	3"x2 1/2"	8.0	6.6	64.0	61.0	113.0
100x50	4"x2"	10.0	5.0	84.0	63.0	125.0
100x80	4"x3"	10.0	8.0	84.0	64.0	140.0
125x80	5"x3"	11.0	8.0	104.0	64.0	160.0
125x100	5"x4"	11.0	10.0	104.0	84.0	173.0
150x80	6"x3"	13.0	8.0	132.0	64.0	195.0
150x100	6"x4"	13.0	10.0	132.0	84.0	208.0
150x125	6"x5"	13.0	11.0	132.0	104.0	217.0
200x100	8"x4"	15.0	10.0	164.0	84.0	236.5
200x150	8"x6"	15.0	13.0	164.0	132.0	264.0

5

自來水用接頭規格

Specification of PVC-U Fittings for Water Supply

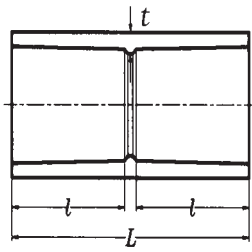

WS型同徑接頭 Coupling

單位：mm

規格	Size	t	l	L
13	3/8"	3.0	26	57
16	1/2"	3.5	30	67
20	3/4"	3.5	35	77
25	1"W	4.0	40	87
30	1 1/4"W	4.0	44	95
40	1 1/2"	4.5	55	117
50	2"	5.0	63	133
65	2 1/2"	6.6	61	145
80	3"	8.0	64	155
100	4"	10.0	84	200
125	5"	11.0	104	240
150	6"	13.0	132	300
200	8"	15.0	164	360

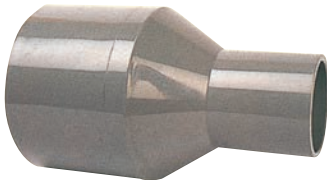
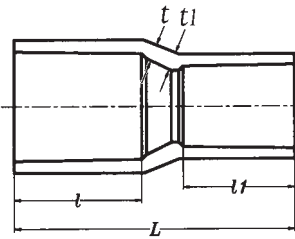

WS型異徑接頭 Reducer Coupling

單位：mm

規格	Size	t	tl	l	ll	L
16x13	1/2" x 3/8"	3.5	3.0	30	26	61
20x13	3/4" x 3/8"	3.5	3.0	35	26	68
20x16	3/4" x 1/2"	3.5	3.5	35	30	71
25x13	1"W x 3/8"	4.0	3.0	40	26	86
25x16	1"W x 1/2"	4.0	3.5	40	30	85
25x20	1"W x 3/4"	4.0	3.5	40	35	84
30x16	1 1/4"W x 1/2"	4.0	3.5	44	30	95
30x20	1 1/4"W x 3/4"	4.0	3.5	44	35	93
30x25	1 1/4"W x 1"W	4.0	4.0	44	40	93
40x20	1 1/2" x 3/4"	4.5	3.5	55	35	113
40x25	1 1/2" x 1"W	4.5	4.0	55	40	114
40x30	1 1/2" x 1 1/4"W	4.5	4.0	55	44	114
50x20	2" x 3/4"	5.0	3.5	63	35	116
50x25	2" x 1"W	5.0	4.0	63	40	140
50x30	2" x 1 1/4"W	5.0	4.0	63	44	136
50x40	2" x 1 1/2"	5.0	4.5	63	55	136
65x40	2 1/2" x 1 1/2"	6.6	4.5	61	55	145
65x50	2 1/2" x 2"	6.6	5.0	61	63	149
80x40	3" x 1 1/2"	8.0	4.5	64	55	153
80x50	3" x 2"	8.0	5.0	64	63	165
80x65	3" x 2 1/2"	8.0	6.6	64	61	159
100x80	4" x 3"	10.0	8.0	84	64	190
125x100	5" x 4"	11.0	10.0	104	84	229
150x100	6" x 4"	13.0	10.0	132	84	295
150x125	6" x 5"	13.0	11.0	132	104	272
200x100	8" x 4"	15.0	10.0	164	84	340
200x125	8" x 5"	15.0	11.0	164	104	345
200x150	8" x 6"	15.0	13.0	164	132	350

5 自來水用接頭規格 Specification of PVC-U Fittings for Water Supply

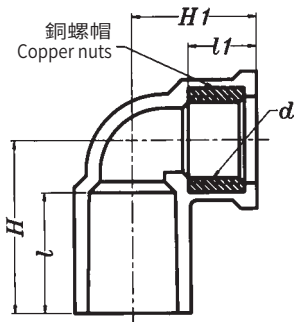

龍入銅接頭 Faucet Fitting—90° Elbow

單位：mm

規格 Size	l	H	螺牙THREAD		H1	
			d	l1		
16	1/2"	30	43	PF1/2"	17	32
20	3/4"	35	51	PF3/4"	19	36

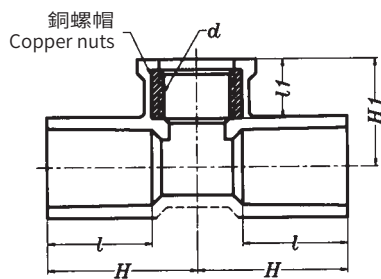

龍T入銅接頭 Faucet Fitting—Fixture TEE

單位：mm

規格 Size	l	H	螺牙THREAD		H1	
			d	l1		
16	1/2"	30	43	PF1/2"	17	32
20	3/4"	35	51	PF3/4"	19	36



註/Note：

五樓以上之建築物，其水龍頭接頭請全部使用入銅製品。

For buildings above fifth floor, please use insert bronze nut for all faucet fittings.

5 自來水用接頭規格 Specification of PVC-U Fittings for Water Supply

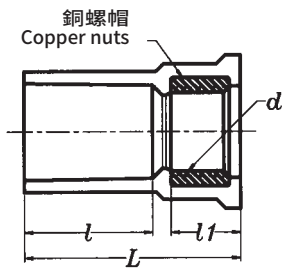

龍S入銅接頭 Faucet Fitting—Female Adapter

單位：mm

規格 Size		<i>l</i>	螺牙THREAD		<i>L</i>
			<i>d</i>	<i>H</i>	
16	1/2"	30	PF1/2"	17	52
20	3/4"	35	PF3/4"	19	59

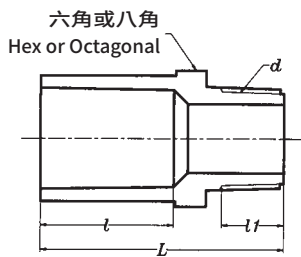

A. 不入銅產品



止閥接頭(塑膠牙)

Male Adapter (Plastic Thread)

單位：mm

規格 Size		<i>l</i>	螺牙THREAD		<i>L</i>
			<i>d</i>	<i>H</i>	
13	3/8"	26	PT1/2"	15	50
16	1/2"	30	PT1/2"	15	54
20	3/4"	35	PT3/4"	17	64
25	1"W	40	PT1"	19	71
30	1 1/4"W	44	PT1 1/4"	22	80
40	1 1/2"	55	PT1 1/2"	22	92
50	2"	63	PT2"	26	106

註/Note：

五樓以上之建築物，其水龍頭接頭請全部使用入銅製品。

For buildings above fifth floor, please use insert bronze nut for all faucet fittings.

5 自來水用接頭規格

Specification of PVC-U Fittings for Water Supply

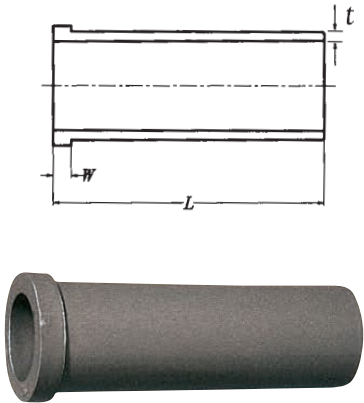

由令 Union

單位: mm

規格 Size		<i>t</i>	<i>W</i>	<i>L</i>
13	3/8"	2.5	5	80
16	1/2"	3.0	5	85
20	3/4"	3.0	6	90
25	1"W	3.5	7	100
30	1 1/4"W	3.5	8	110
40	1 1/2"	4.0	8	120
50	2"	4.5	9	130

圖1 FIG.1



圖2 FIG.2



塞頭 Cap

單位: mm

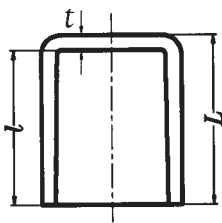
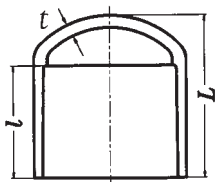
規格 Size		<i>t</i>	<i>l</i>	<i>L</i>	
圖1 FIG.1	13	3/8"	3.0	26	29
	16	1/2"	3.5	30	33.5
	20	3/4"	3.5	35	38.5
	25	1"W	4.0	40	44
	30	1 1/4"W	4.0	44	48
	40	1 1/2"	4.5	55	59.5
圖2 FIG.2	50	2"	5.0	63	68
	65	2 1/2"	6.6	61	96
	80	3"	8.0	64	105
	100	4"	10.0	84	138
	125	5"	11.0	104	160
	150	6"	13.0	132	205
200	8"	15.0	164	257	

5 自來水用接頭規格

Specification of PVC-U Fittings for Water Supply

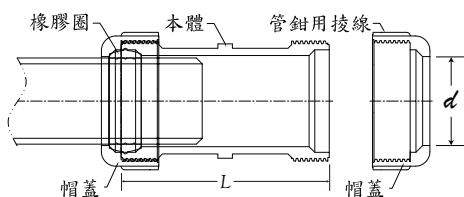

伸縮接頭 Compression Fitting

特性 Characteristics:

1. 施工簡便、容易裝卸、施工不受天候影響、施工後可立即通水、耐水壓强度高、具有伸縮效果。
 2. 適用於埋設地下管線，若用於地上配管時，伸縮接頭需予以固定住，防止滑動。
1. Compression fitting, which is easy for construction and loading without weather impact, features superb compression and water pressure resistance.
 2. Compression fitting, not only used for underground pipeline but also suitable for above-ground pipeline, needs to be fixed tightly to avoid sliding.

用途 Applications:

1. 適用於中小口徑壓力管線。
 2. 可吸收直線配管因熱脹冷縮所產生的伸縮量。
 3. 作為管線破裂後之緊急快速搶修接頭。
1. Applicable to high pressure pipeline (for small and medium size of compression fittings use).
 2. Able to absorb piping's expansion resulted from thermal expansion and contraction.
 3. Suitable for fixing damaged compression fittings of cracked pipeline.

單位：mm

規格 Size	內徑 d 及許可差 Inside Diameter and Tolerance	本體長度 L
16	1/2"	22.8 ± 0.3
20	3/4"	26.8 ± 0.3
* 25	1"W	33.0 ± 0.4
* 30	1 1/4"W	39.0 ± 0.4
* 40	1 1/2"	49.2 ± 0.4
50	2"	61.5 ± 0.5
65	2 1/2"	77.5 ± 0.5
80	3"	90.8 ± 0.5
100	4"	116.0 ± 0.6

註/Remark :

1. 橡膠圈材質依CNS 10774之I類A5之規定。
 2. * 表示模具開發中。
 3. 伸縮接頭施工方式請詳閱PVC-U管施工應注意事項第13項(Page 31)。
1. The rubber ring material is in accordance with the A5 of Class I in CNS 10774.
 2. * Means the mold is developing.
 3. Compression coupling construction method, please read the notice items for PVC-U piping instructions, item 13 (Page 31).

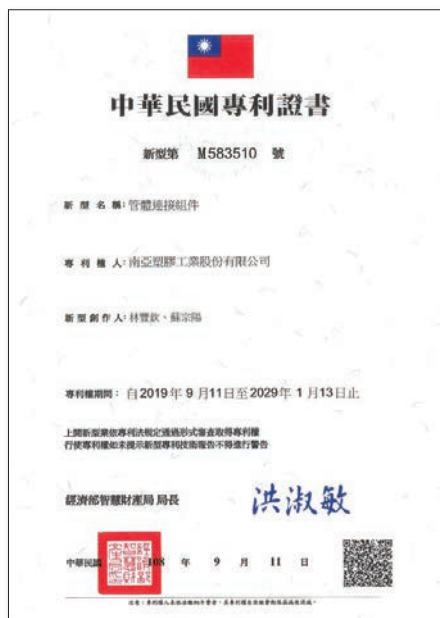
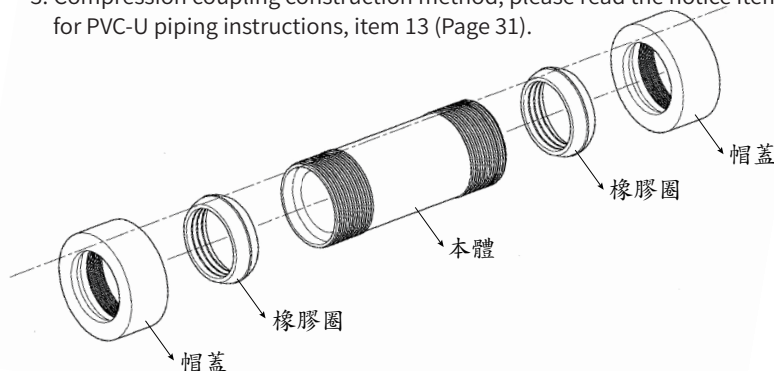

6 灰色一般用接頭規格(厚、薄) Specification of gray fitting (thick and thin)

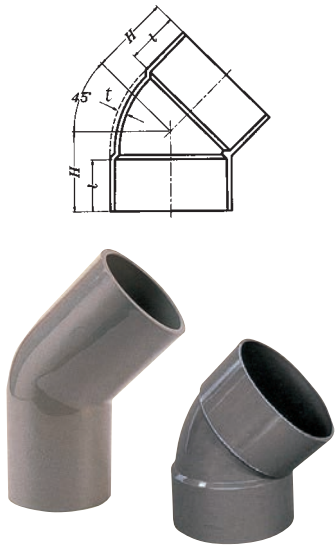

45° L 型接頭 45° Elbow

單位：mm

規格 Size	厚接頭(45° OL) Thick			薄接頭(45° 排L) Thin		
	<i>t</i>	<i>l</i>	<i>H</i>	<i>t</i>	<i>l</i>	<i>H</i>
16	1/2"	3.5	30	38		
20	3/4"	3.5	35	44		
25	1"W	4.0	40	51		
30	1 1/4"W	4.0	44	56		
40	1 1/2"	4.5	55	69	2.0	22
50	2"	5.0	63	80	2.0	25
65	2 1/2"	5.0	69	90	2.5	35
80	3"	6.0	72	95	3.0	40
90	3 1/2"	6.5	80	105	3.0	50
100	4"	7.5	92	121	3.5	50
125	5"	8.0	112	150	3.5	65
150	6"	9.0	140	186	4.0	80
200	8"	10.5	172	224	7.5	100
250	10"	13.0	185	248	8.5	130
300	12"				10.0	150

註：紅色字體為自來水用接頭規格，亦可用於灰色一般管路配管。
Note: The red font refers the specification of tap water fitting which can also be used for gray piping project.

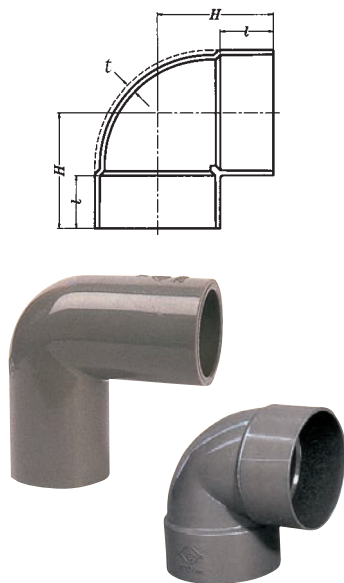

90° L 型接頭 90° Elbow

單位：mm

規格 Size	厚接頭(90° OL) Thick			薄接頭(90° 排L) Thin		
	<i>t</i>	<i>l</i>	<i>H</i>	<i>t</i>	<i>l</i>	<i>H</i>
13	3/8"	3.0	26	36		
16	1/2"	3.5	30	43		
20	3/4"	3.5	35	50		
25	1"W	4.0	40	58		
30	1 1/4"W	4.0	44	65		
40	1 1/2"	4.5	55	82	2.0	22
50	2"	5.0	63	96	2.0	25
65	2 1/2"	5.0	69	110	3.0	35
80	3"	6.0	72	120	3.0	40
90	3 1/2"	6.5	80	135	3.0	50
100	4"	7.5	92	152	3.5	50
125	5"	8.0	112	188	3.5	65
150	6"	9.0	140	228	4.0	80
200	8"	10.5	172	288	7.5	100
250	10"	13.0	185	326	8.5	130
					10.0	150

註：紅色字體為自來水用接頭規格，亦可用於灰色一般管路配管。
Note: The red font refers the specification of tap water fitting which can also be used for gray piping project.

註/Note：

厚規格製品亦可依上列圖示之虛線製造。

Thick product of fitting can also be manufactured according to the dotted line of above diagram.

6 灰色一般用接頭規格(厚、薄) Specification of gray fitting (thick and thin)

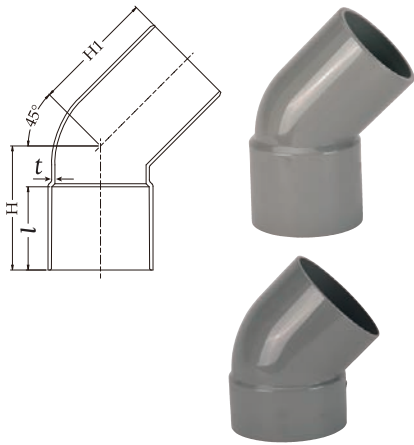

45° L型單放口接頭 45° Elbow with Spigot End 單位: mm

規格 Size	厚接頭(45° OL) Thick				薄接頭(45° 排L) Thin			
	t	l	H	H1	t	l	H	H1
40 1½"	4.5	55	69	69	2.0	22	47.5	34
50 2"	4.0	63	85	85	2.0	25	57	40
65 2½"					2.5	35	75	53
80 3"	5.5	72	95	95	2.5	40	86.5	61
90 3½"					2.5	50	102	73
100 4"	7.0	92	121	121	3.5	50	110	78
125 5"	7.5	112	148	148				
150 6"	8.5	140	180	180				

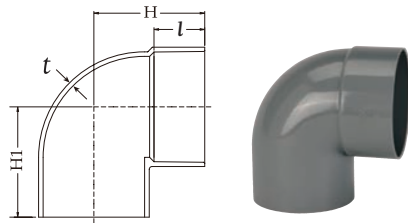

90° L型單放口接頭 90° Elbow with Spigot End 單位: mm

規格 Size	厚接頭(90° OL) Thick				薄接頭(90° 排L) Thin			
	t	l	H	H1	t	l	H	H1
40 1½"	4.5	55	82	85	2.0	22	47.5	49
50 2"	4.0	63	96	101	2.0	25	57	58.5
65 2½"					2.5	35	75	76.5
80 3"					2.5	40	86.5	88
90 3½"					2.5	50	102	103.5
100 4"	7.0	92	152	159.5	3.5	50	110	114

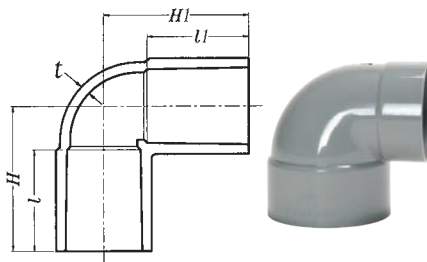

90° L型異徑接頭 90° Reducer Elbow 單位: mm

規格 Size	厚接頭(90° OL) Thick					薄接頭(90° 排L) Thin				
	t	l	ll	H	H1	t	l	ll	H	H1
20x16 ¾"x½"	3.5	35	30	48	44.5					
25x16 1"Wx½"	4	40	30	53	48.5					
25x20 1"Wx¾"	4	40	35	55	53.5					
65x50 2½"x2"						3.0	35	25	69	66

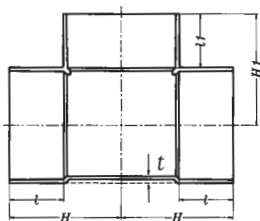

T型同徑接頭 Tee 單位: mm

規格 Size	厚接頭(OT) Thick					薄接頭(排T) Thin				
	t	l	ll	H	H1	t	l	ll	H	H1
13 ⅜"	3.0	26	26	36	36					
16 ½"	3.5	30	30	43	43					
20 ¾"	3.5	35	35	50	50					
25 1"W	4.0	40	40	58	58					
30 1¼"W	4.0	44	44	65	65					
40 1½"	4.5	55	55	82	82	2.0	22	22	48	48
50 2"	5.0	63	63	96	96	2.0	25	25	59	59
65 2½"	6.6	61	61	110	110	2.5	35	35	77	77
80 3"	8.0	64	64	120	120	3.0	40	40	88	88
90 3½"	6.5	80	80	135	135	3.0	50	50	102	102
100 4"	10.0	84	84	152	152	3.5	50	50	112	112
125 5"	8.0	112	112	188	188	3.5	65	65	145	145
150 6"	9.0	140	140	228	228	4.0	80	50	167	167
200 8"	10.5	172	172	287.5	287.5	7.5	100	100	215	215
250 10"	13.0	185	185	325	325	8.5	130	130	270	270
300 12"						10.0	150	150	316	316

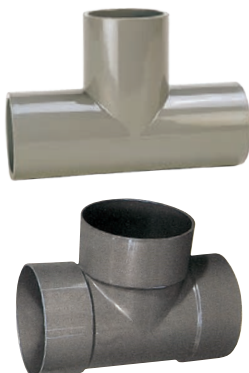

註: 紅色字體為自來水用接頭規格, 亦可用於灰色一般管路配管。
Note: The red font refers the specification of tap water fitting which can also be used for gray piping project.

6 灰色一般用接頭規格(厚、薄) Specification of gray fitting (thick and thin)

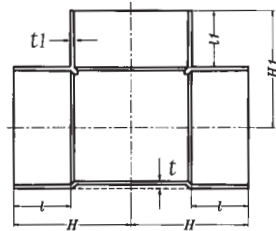

T型異徑接頭 Reducer Tee

單位 : mm

規格 Size		厚接頭(OT) Thick						薄接頭(排T) Thin					
		t	tI	l	II	H	HI	t	tI	l	II	H	HI
16x13	1/2"x3/8"	3.5	3.0	30	26	41	38						
20x13	3/4"x3/8"	3.5	3.0	35	26	46	40						
20x16	3/4"x1/2"	3.5	3.5	35	30	48	45						
25x13	1"Wx3/8"	4.0	3.0	40	26	51	43						
25x16	1"Wx1/2"	4.0	3.5	40	30	53	48						
25x20	1"Wx3/4"	4.0	3.5	40	35	55	53						
30x13	1 1/4"Wx3/8"	4.0	3.0	44	26	55	46						
30x16	1 1/4"Wx1/2"	4.0	3.5	44	30	57	51						
30x20	1 1/4"Wx3/4"	4.0	3.5	44	35	59	56						
30x25	1 1/4"Wx1"W	4.0	3.5	44	40	62	61						
40x13	1 1/2"x3/8"	4.5	3.0	55	26	66	52						
40x16	1 1/2"x1/2"	4.5	3.5	55	30	68	57						
40x20	1 1/2"x3/4"	4.5	3.5	55	35	70	62						
40x25	1 1/2"x1"W	4.5	3.5	55	40	73	67						
40x30	1 1/2"x1 1/4"W	4.5	4.0	55	44	76	71						
50x13	2"x3/8"	5.0	3.0	63	26	74	58						
50x16	2"x1/2"	5.0	3.5	63	30	76	63						
50x20	2"x3/4"	5.0	3.5	63	35	78	68	2.0	2.0	25.0	20.0	45	51
50x25	2"x1"W	5.0	4.0	63	40	81	73						
50x30	2"x1 1/4"W	5.0	4.0	63	44	84	77						
50x40	2"x1 1/2"	5.0	4.5	63	55	90	88	2.0	2.0	25.0	22.0	52	55
65x20	2 1/2"x3/4"	5.0	3.5	69	35	84	74	2.5	2.0	35.0	20.0	57.5	59
65x25	2 1/2"x1"W	5.0	3.5	61	40	82	82						
65x40	2 1/2"x1 1/2"	6.6	4.5	61	55	100	96	3.0	2.0	35.0	22.0	63	62
65x50	2 1/2"x2"	6.6	5.0	61	63	101	104	2.5	2.0	35.0	25.0	68	65
80x20	3"x3/4"	6.0	3.5	72	35	90	82						
80x25	3"x1"W	8.0	4.0	64	40	93	88						
80x40	3"x1 1/2"	8.0	4.5	64	55	100	102	3.0	2.0	40.0	22.0	67	70
80x50	3"x2"	6.0	4.5	72	63	105	115	3.0	2.0	40.0	25.0	73	73
80x65	3"x2 1/2"	6.0	5.0	72	69	113	117						
90x40	3 1/2"x1 1/2"							3.0	2.0	50.0	22.0	78	74
90x50	3 1/2"x2"							3.0	2.0	50.0	25.0	84	77
90x65	3 1/2"x2 1/2"							3.0	3.0	50.0	35.0	91	88
100x40	4"x1 1/2"	7.5	4.0	92	55	120	115	3.5	2.0	50.0	22.0	76	83
100x50	4"x2"	7.5	4.5	92	63	125	122	3.5	2.0	50.0	25.0	85.5	85
100x65	4"x2 1/2"							3.5	3.0	50.0	35.0	92	96
100x80	4"x3"	7.5	6.0	92	72	140	132	3.5	3.0	50.0	40.0	98	101
125x65	5"x2 1/2"							3.5	3.0	65.0	35.0	107	110
125x80	5"x3"	8.0	6.0	112	72	160	148	3.5	3.0	65.0	40.0	113	115
125x100	5"x4"	8.0	7.5	112	92	174	168	3.5	3.5	65.0	50.0	127.5	125
150x65	6"x2 1/2"							4.0	3.0	80.0	35.0	122	121
150x80	6"x3"	9.0	6.0	140	72	190	155	4.0	3.0	80.0	40.0	127	126
150x100	6"x4"	9.0	7.5	140	92	202	182	4.0	3.5	80.0	50.0	142	137
150x125	6"x5"	9.0	8.0	140	112	214.5	200						
200x100	8"x4"	10.5	7.5	172	92	236.5	204	7.5	3.5	100.0	50.0	165	165
200x150	8"x6"	10.5	9.0	172	140	264	252	7.5	4.0	100.0	80.0	185	195

註：1. 紅色字體為自來水用接頭規格，亦可用於灰色一般管路配管。

2. 厚規格製品亦可依上列圖示之虛線製造。

Note: 1.The red font refers the specification of tap water fitting which can also be used for gray piping project.

2.Thick product of fitting can also be manufactured according to the dotted line of above diagram.

6 灰色一般用接頭規格(厚、薄) Specification of gray fitting (thick and thin)

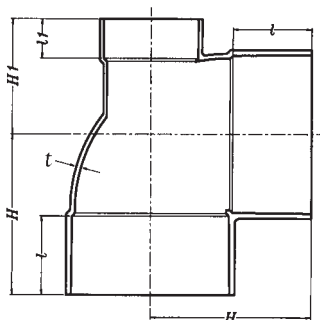

排氣T型排水接頭 Vent Tee

單位: mm

規格	Size	t	t1	l	l1	H	H1
90x40	3½"x1½"	3.0	2.0	50	22	102	70
90x50	3½"x2"	3.0	2.0	50	25	102	73
100x50	4"x2"	3.5	2.0	50	25	110	80

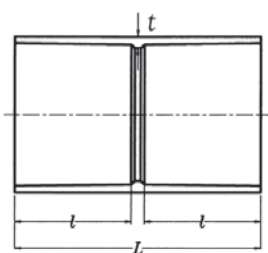

S型同徑接頭 Coupling

單位: mm

規格	Size	厚接頭(OS) Thick			薄接頭(排S) Thin		
		t	l	L	t	l	L
13	¾"	3.0	26	57			
16	½"	3.5	30	67			
20	¾"	3.5	35	77			
25	1"W	4.0	40	87			
30	1¼"W	4.0	44	95			
40	1½"	4.5	55	117	2.0	22	47
50	2"	5.0	63	133	2.0	25	53
65	2½"	6.6	61	145	2.5	35	73
80	3"	6.0	72	152	3.0	40	84
90	3½"	6.5	80	166	3.0	50	104
100	4"	7.5	92	200	3.5	50	104
125	5"	8.0	112	235	3.5	65	134
150	6"	9.0	140	300	4.0	80	164
200	8"	10.5	172	360	7.5	100	205
250	10"	13.0	185	400	8.5	130	270



註：紅色字體為自來水用接頭規格，亦可用於灰色一般管路配管。

Note: The red font refers the specification of tap water fitting which can also be used for gray piping project.

6 灰色一般用接頭規格(厚、薄) Specification of gray fitting (thick and thin)

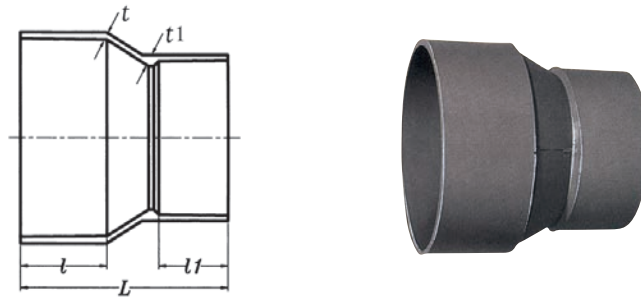

S型異徑接頭 Reducer Coupling

單位: mm

規格 Size	厚接頭(OS) Thick					薄接頭(排S) Thin					
	t	t1	l	l1	L	t	t1	l	l1	L	
16x13	1/2"x3/8"	3.5	3.0	30	26	61					
20x13	3/4"x3/8"	3.5	3.0	35	26	68					
20x16	3/4"x1/2"	3.5	3.5	35	30	71					
25x16	1"Wx1/2"	4.0	3.5	40	30	85					
25x20	1"Wx3/4"	4.0	3.5	40	35	84					
28x25	1"x1W"	4.0	4.0	40	40	90					
30x16	1 1/4"Wx1/2"	4.0	3.5	44	30	95					
30x20	1 1/4"Wx3/4"	4.0	3.5	44	35	93					
30x25	1 1/4"Wx1"W	4.0	4.0	44	40	93					
35x30	1 1/4"x1 1/4"W	4.0	4.0	44	44	100					
40x16	1 1/2"x1/2"	4.5	3.5	55	30	114					
40x20	1 1/2"x3/4"	4.5	3.5	55	35	113					
40x25	1 1/2"x1"W	4.5	4.0	55	40	114					
40x30	1 1/2"x1 1/4"W	4.5	4.0	55	44	114					
50x16	2"x1/2"	5.0	3.5	63	30	120					
50x20	2"x3/4"	5.0	3.5	63	35	116					
50x25	2"x1"W	5.0	4.0	63	40	140					
50x30	2"x1 1/4"W	5.0	4.0	63	44	136					
50x40	2"x1 1/2"	5.0	4.5	63	55	136	2.0	2.0	25	22	67
65x40	2 1/2"x1 1/2"	5.0	4.0	69	55	150	2.5	2.0	35	22	77
65x50	2 1/2"x2"	5.0	4.5	69	63	153	2.5	2.0	35	25	80
80x40	3"x1 1/2"	6.0	4.0	72	55	165	3.0	2.0	40	22	87
80x50	3"x2"	8.0	5.0	64	63	165	3.0	2.0	40	25	90
80x65	3"x2 1/2"	6.0	5.0	72	69	165	3.0	2.5	40	35	90
90x40	3 1/2"x1 1/2"						3.0	2.0	50	22	102
90x50	3 1/2"x2"						3.0	2.0	50	25	105
90x65	3 1/2"x2 1/2"						3.0	2.5	50	35	115
90x80	3 1/2"x3"						3.0	3.0	50	40	115
100x40	4"x1 1/2"	7.5	4.5	92	55	190					
100x50	4"x2"	7.5	5.0	92	63	208	3.5	2.0	50	25	105
100x65	4"x2 1/2"	7.5	6.0	92	69	200	3.5	2.5	50	35	115
100x80	4"x3"	10.0	8.0	84	64	190	3.5	3.0	50	40	120
100x90	4"x3 1/2"						3.5	3.0	50	50	120
125x65	5"x2 1/2"						3.5	2.5	65	35	130
125x80	5"x3"	8.0	7.5	112	72	210	3.5	3.0	65	40	140
125x100	5"x4"	11.0	10.0	104	84	229	3.5	3.5	65	50	150
150x65	6"x2 1/2"						4.0	2.5	80	35	160
150x80	6"x3"	9.0	6.0	140	72	260	4.0	3.0	80	40	165
150x100	6"x4"	9.0	7.5	140	92	280	4.0	3.5	80	50	170
150x125	6"x5"	9.0	8.0	140	112	295	4.0	3.5	80	65	170
200x100	8"x4"	10.5	7.5	172	92	340					
200x125	8"x5"	10.5	8.0	172	112	345					
200x150	8"x6"	10.5	9.0	172	140	350	7.5	4.0	100	80	250
250x200	10"x8"	13.0	10.5	185	172	420	8.5	7.5	130	100	300
300x200	12"x8"	15.0	10.5	230	172	495					

註: 紅色字體為自來水用接頭規格, 亦可用於灰色一般管路配管。

Note: The red font refers the specification of tap water fitting which can also be used for gray piping project.

6 灰色一般用接頭規格(厚、薄) Specification of gray fitting (thick and thin)

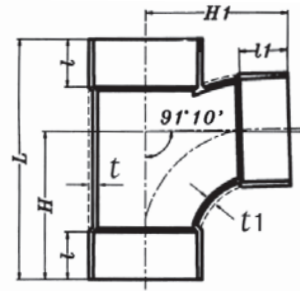

順T型同徑接頭 Sanitary Tee

單位：mm

規格 Size		厚接頭(O順T) Thick						薄接頭(排順T) Thin					
		t	l	II	H	HI	L	t	l	II	H	HI	L
40	1½"	4.5	55	55	111	111	180	2.0	22	22	68	68	104
50	2"	5.0	63	63	114	127	200	2.0	25	25	87	88	135
65	2½"	5.0	69	69	132	140	234	3.0	35	35	109	105	177
80	3"	6.0	72	72	177	172	280	3.0	40	40	123	125	205
90	3½"							3.0	50	50	130	140	230
100	4"	7.5	92	92	224	219	355	3.5	50	50	155	155	255
125	5"	8.0	112	112	252	233	416	3.5	65	65	200	200	325
150	6"	9.0	140	140	290	295	495	4.0	80	80	238	238	390
200	8"	10.5	172	172	347	360	615	7.5	100	100	300	300	490
250	10"							8.5	130	130	370	370	615

順T型異徑接頭 Reducer Sanitary Tee

單位：mm

規格 Size		厚接頭(O順T) Thick							薄接頭(排順T) Thin						
		t	tI	l	II	H	HI	L	t	tI	l	II	H	HI	L
50x40	2"x1½"	5.0	4.5	63	55	114	118	192	2.0	2.0	25	22	70	75	114
65x40	2½"x1½"								2.5	2.0	35	22	87	87	138
65x50	2½"x2"	5.0	5.0	69	63	128	130	218	2.5	2.0	35	25	93	92	153
80x40	3"x1½"								3.0	2.0	40	22	90	100	147
80x50	3"x2"	6.0	5.0	72	63	140	145	235	3.0	2.0	40	25	98	105	162
90x40	3½"x1½"								3.0	2.0	50	22	100	100	168
90x50	3½"x2"								3.0	2.0	50	25	109	110	183
90x65	3½"x2½"								3.0	2.5	50	35	115	120	200
100x40	4"x1½"								3.5	2.0	50	22	90	110	160
100x50	4"x2"	7.5	5.0	92	63	154	152	270	3.5	2.0	50	25	100	118	175
100x65	4"x2½"								3.5	3.0	50	35	125	125	210
100x80	4"x3"	7.5	6.0	92	72	194	182	318	3.5	3.0	50	40	133	140	220
125x65	5"x2½"								3.5	2.5	65	35	140	140	238
125x80	5"x3"	8.0	6.0	112	72	235	198	350	3.5	3.0	65	40	130	145	235
125x100	5"x4"	8.0	7.5	112	92	235	219	388	3.5	3.5	65	50	155	160	270
150x50	6"x2"	9.0	5.0	140	63	215	180	420	4.0	2.0	80	25	132	155	237
150x80	6"x3"	9.0	6.0	140	72	230	207	420	4.0	3.0	80	40	151	170	272
150x100	6"x4"	9.0	7.5	140	92	246	234	425	4.0	3.5	80	50	170	180	300
150x125	6"x5"	9.0	8.0	140	112	273	252	468							
200x50	8"x2"	10.5	5.0	172	63	307	210	440							
200x80	8"x3"	10.5	6.0	172	72	307	235	470							
200x100	8"x4"	10.5	7.5	172	92	307	263	510							
200x150	8"x6"	10.5	9.0	172	140	307	320	560	7.5	4.0	100	80	235	265	410
250x150	10"x6"	11.5	9.0	185	140	332	345	588	8.5	4.0	130	80	271	285	474
250x200	10"x8"								8.5	7.5	130	100	312	323	537

註/Note：

厚規格製品亦可依上列圖示之虛線製造。

Thick product of fitting can also be manufactured according to the dotted line of above diagram.

6 灰色一般用接頭規格(厚、薄) Specification of gray fitting (thick and thin)

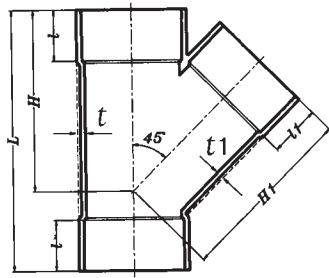

Y型同徑接頭 Wye

單位: mm

規格 Size		厚接頭(OY) Thick						薄接頭(排Y) Thin					
		t	l	l1	H	H1	L	t	l	l1	H	H1	L
40	1½"	4.5	55	55	116	119	185	2.0	22	22	80	84	114
50	2"	5.0	63	63	141	142	220	2.0	25	25	100	103	142
65	2½"	5.0	69	69	166	161	260	3.0	35	35	127	133	185
80	3"	6.0	72	72	180	188	280	3.0	40	40	152	154	213
90	3½"							3.0	50	50	171.5	177.5	247
100	4"	7.5	92	92	230	240	355	3.5	50	50	193	194	275
125	5"	8.0	112	112	282	292	434	3.5	65	65	235	240	335
150	6"	9.0	140	140	344	352	530	4.0	80	80	285	285	410
200	8"	10.5	172	172	446	433	690	7.5	100	100	365	375	520

Y型異徑接頭 Reducer Wye

單位: mm

規格 Size		厚接頭(OY) Thick						薄接頭(排Y) Thin							
		t	t1	l	l1	H	H1	L	t	t1	l	l1	H	H1	L
50x40	2"x1½"	5.0	4.5	63	55	132	128	202	2.0	2	25	22	91	91	124
65x40	2½"x1½"	5.0	4.5	69	55	148	133	223	3.0	2	35	22	109	105	148
65x50	2½"x2"	5.0	5.0	69	63	148	152	230	3.0	2	35	25	118	114	162
80x40	3"x1½"								3.0	2	40	22	120	115	160
80x50	3"x2"	6.0	5.0	72	63	164	164	239	3.0	2	40	25	130	123	170
90x40	3½"x1½"								3.0	2	50	22	136	122	177
90x50	3½"x2"								3.0	2	50	25	144	131	192
90x65	3½"x2½"								3.0	2.5	50	35	155	149	217
100x40	4"x1½"								3.5	2	50	22	143	126	177
100x50	4"x2"	7.5	5.0	92	63	195	185	285	3.5	2	50	25	152	142	195
100x65	4"x2½"								3.5	3	50	35	162	160	217
100x80	4"x3"	7.5	6.0	92	72	213	206	319	3.5	3	50	40	173	171	238
125x50	5"x2"	8.0	5.0	112	63	233	192	337	3.5	2	65	25	183	155	228
125x65	5"x2½"								3.5	2.5	65	35	193	180	250
125x80	5"x3"	8.0	6.0	112	72	252	216	372	3.5	3	65	40	205	187	273
125x100	5"x4"	8.0	7.5	112	92	272	252	415	3.5	3.5	65	50	216	212	300
150x50	6"x2"	9.0	5.0	140	63	270	228	385							
150x65	6"x2½"								4.0	2.5	80	35	220	197	280
150x80	6"x3"	9.0	6.0	140	72	282	240	412	4.0	3	80	40	227	206	300
150x100	6"x4"	9.0	7.5	140	92	294	274	455	4.0	3.5	80	50	245	230	340
150x125	6"x5"	9.0	8.0	140	112	322	310	500							
200x50	8"x2"	10.5	5.0	172	63	327	258	445							
200x80	8"x3"	10.5	6.0	172	72	345	282	485							
200x100	8"x4"	10.5	7.5	172	92	362	316	520	7.5	3.5	100	50	292	268	380
200x125	8"x5"	10.5	8.0	172	112	382	349	560	7.5	3.5	100	50	292	268	380
200x150	8"x6"	10.5	9.0	172	140	400	394	600	7.5	4	100	80	328	326	445
250x150	10"x6"	13.0	9.0	185	140	450	430	625							

註：厚規格製品亦可依上列圖示之虛線製造。

Note: Thick product of fitting can also be manufactured according to the dotted line of above diagram.

Y型接頭單插口 Wye With Spigot End 單位: mm

規格 Size		薄接頭(排Y) Thin					
		厚度	l	l1	H	H1	L
50	2"	2	25	31	98.6	103	142

6 灰色一般用接頭規格 Specification of gray fitting

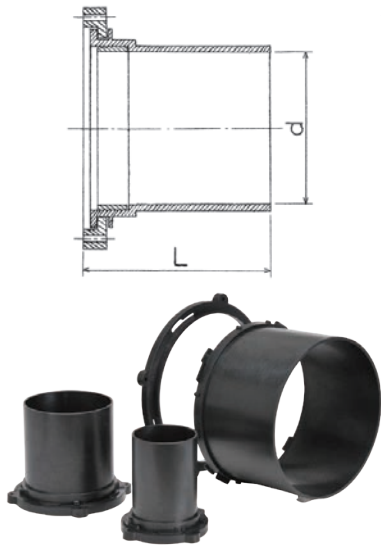

組合式穿樑接頭 Assembly type Beam Fittings 單位：mm

規格 Size	d	L
2"	62	99
2½"	78	99
3"	91	105
4"	116	119
5"	142	119
6"	167	119

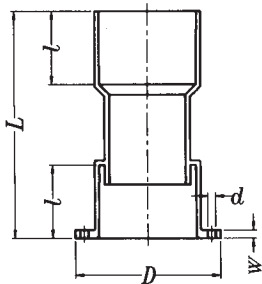

樓板接頭 Slab Joint 單位：mm

規格 Size	D	d	W	l	L
40 1½"	52.5	3.5	5	40	140
50 2"	65	3.5	5	45	140
80 3"	96	3.5	5	50	140
80x65x50 3"x2½"x2"	96	3.5	5	40	140
100 4"	122	3.5	5	50	140

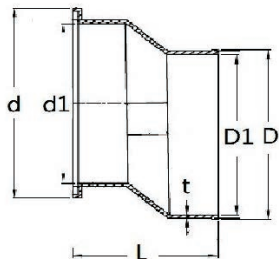

外壁偏心接頭 Eccentric Fitting 單位：mm

規格 Size	D	D1	L	t	d
4"	126	116	155	3.5	147
5"	146	137	149	3.5	186
6"	174	164	141	3.5	194



6 灰色一般用接頭規格 Specification of gray fitting

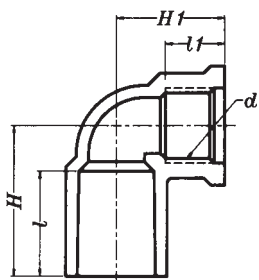

龍L接頭(塑膠牙)

Faucet Fitting – 90° Elbow (Plastic Thread)

單位：mm

規格 Size		<i>l</i>	<i>H</i>	螺牙THREAD		<i>H1</i>
				<i>d</i>	<i>l1</i>	
13x16	3/8"x1/2"	26	38	PT1/2"	17	29
16	1/2"	30	43	PT1/2"	17	32
20	3/4"	35	51	PT3/4"	19	36

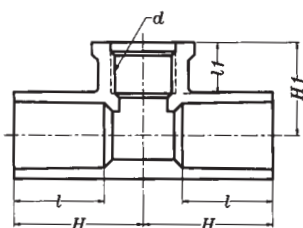

龍T接頭(塑膠牙)

Faucet Fitting – Fixture Tee (Plastic Thread)

單位：mm

規格 Size		<i>l</i>	<i>H</i>	螺牙THREAD		<i>H1</i>
				<i>d</i>	<i>l1</i>	
13x16	3/8"x1/2"	26	38	PT1/2"	17	29
16	1/2"	30	43	PT1/2"	17	32
20x16	3/4"x1/2"	35	47	PT1/2"	17	34
20	3/4"	35	51	PT3/4"	19	36

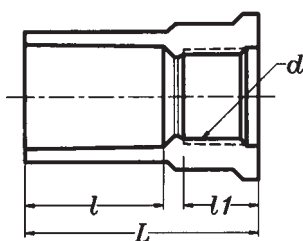

龍S接頭(塑膠牙)

Faucet Fitting – Female Adapter (Plastic Thread)

單位：mm

規格 Size		<i>l</i>	螺牙THREAD		<i>L</i>
			<i>d</i>	<i>l1</i>	
13x16	3/8"x1/2"	26	PT1/2"	17	47
16	1/2"	30	PT1/2"	19	57
20	3/4"	35	PT3/4"	19	59

6 灰色一般用接頭規格 Specification of gray fitting

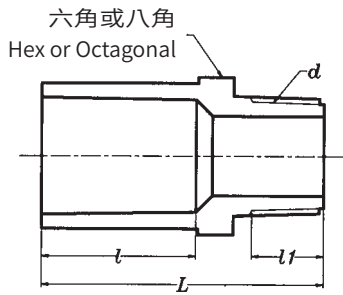

止閘接頭(塑膠牙)

Male Adapter (Plastic Thread)

單位: mm

規格 Size	<i>l</i>	螺牙 THREAD		<i>L</i>
		<i>d</i>	<i>ll</i>	
13	3/8"	26	PT1/2"	50
16	1/2"	30	PT1/2"	54
20	3/4"	35	PT3/4"	64
25	1"W	40	PT1"	71
30	1 1/4"W	44	PT1 1/4"	80
40	1 1/2"	55	PT1 1/2"	92
50	2"	63	PT2"	106
65	2 1/2"	69	PT2 1/2"	120
80	3"	72	PT3"	126
100	4"	92	PT4"	146
125	5"	112	PT5"	177
150	6"	140	PT6"	213

註：紅色字體為自來水用接頭規格，亦可用於灰色一般管路配管。
Note: The red font refers the specification of tap water fitting which can also be used for gray piping project.

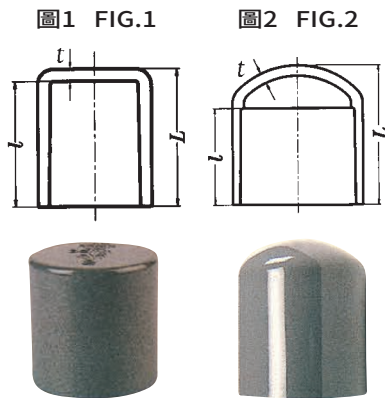

塞頭 Cap

單位: mm

規格 Size		<i>t</i>	<i>l</i>	<i>L</i>
圖1 FIG.1	16	1/2"	3.5	30
	20	3/4"	3.5	35
	25	1"W	4.0	40
	30	1 1/4"W	4.0	44
	40	1 1/2"	4.5	55
圖2 FIG.2	50	2"	5.0	63
	65	2 1/2"	6.6	69
	80	3"	8.0	72
	90	3 1/2"	6.0	80
	100	4"	10.0	92
	125	5"	11.0	112
	150	6"	13.0	140
	200	8"	15.0	172
250	10"	15.0	185	

註：紅色字體為自來水用接頭規格，亦可用於灰色一般管路配管。
Note: The red font refers the specification of tap water fitting which can also be used for gray piping project.

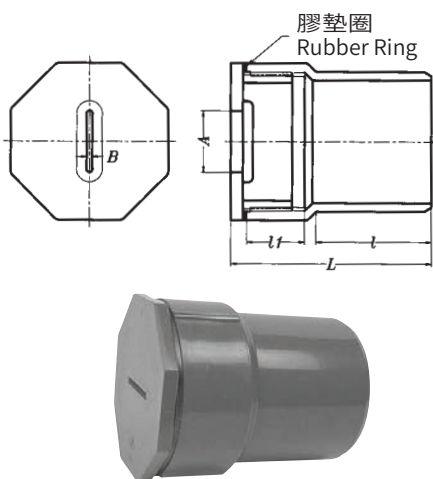

清除孔接頭 Cleanout Bushing

單位: mm

規格 Size	<i>A</i>	<i>B</i>	<i>l</i>	<i>ll</i>	<i>L</i>
50	2"	30	4.5	59	90
80	3"	50	4.5	75	120
100	4"	50	4.5	93	150
125	5"	80	10	120	180
150	6"	125	10	128	190
200	8"	160	10	175	240

6 灰色一般用接頭規格 Specification of gray fitting

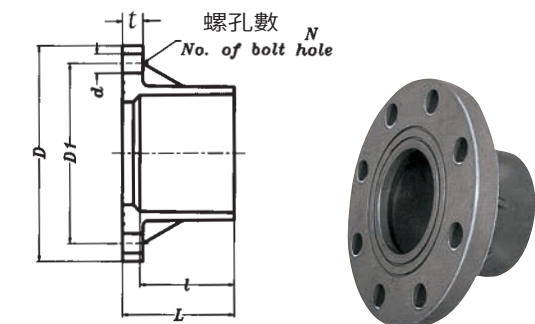

法蘭接頭 Flange

單位: mm

規格 Size	t	D	DI	l	螺孔 Hole		L	
					d	N		
40	1½"	17	140	105	55	19	4	68
50	2"	17	155	120	63	19	4	76
65	2½"	18	175	140	69	19	4	83
80	3"	18	185	150	72	19	8	86
100	4"	18	210	175	92	19	8	107
125	5"	20	250	210	112	23	8	130
150	6"	22	280	240	140	23	8	165
200	8"	22	330	290	172	23	12	195
250	10"	24	400	355	185	25	12	235
300	12"	30	445	400	230	25	16	295

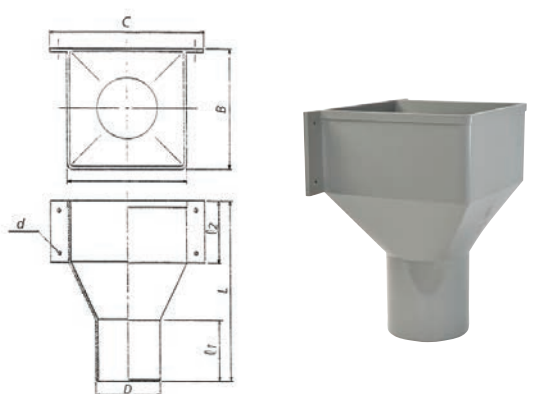

止水板接頭

Coupling with Waterstop Board

單位: mm

規格 Size	D	Z	L
2"	160	4	147
2-½"	180	4.5	147
3"	195	5	147
4"	220	5	147
5"	250	5.5	167
6"	275	6	223

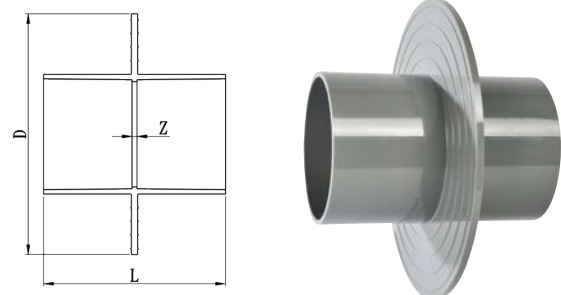

雙層止水板接頭

Coupling with Double Waterstop Board

單位: mm

規格 Size	D	D1	Z	L
5"	210	240	5	148

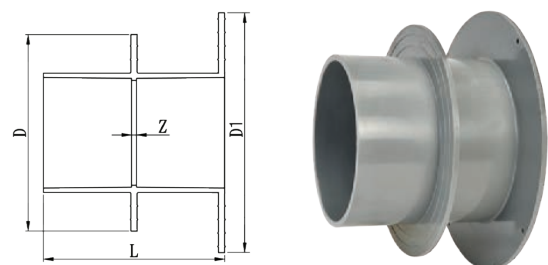

通氣口接頭 Air Vent

單位: mm

規格 Size	ℓ	L
2"	22	50
2-½"	22	52
3"	22	54

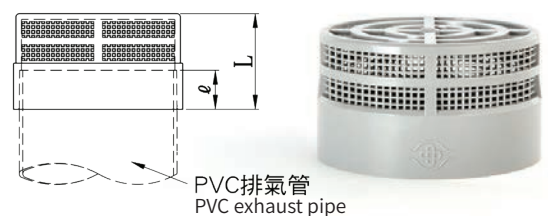

PVC排氣管
PVC exhaust pipe

7

HI耐衝擊PVC-U接頭規格

Specification for HI high impact PVC-U fittings drainage

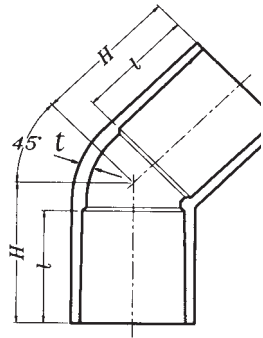

45° L 型接頭 45° Elbow 單位 : mm

規格	Size	t	l	H
○ 16	1/2"	3.5	30	38
○ 20	3/4"	3.5	35	44
○ 25	1"W	4.0	40	51
○ 30	1 1/4"W	4.0	44	56
○ 40	1 1/2"	4.5	55	69
○ 50	2"	5.0	63	80
○ 65	2 1/2"	5.0	69	90
○ 80	3"	8.0	64	97
○ 100	4"	10.0	84	122
○ 125	5"	11.0	104	149
○ 150	6"	13.0	132	184
○ 200	8"	15.0	164	224
△ 250	10"	13.0	185	248

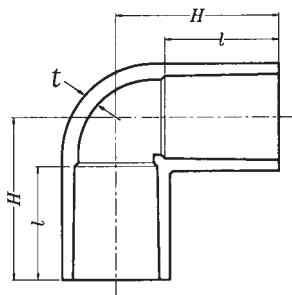

90° L 型接頭 90° Elbow 單位 : mm

規格	Size	t	l	H
○ 16	1/2"	3.5	30	43
○ 20	3/4"	3.5	35	50
○ 25	1"W	4.0	40	58
○ 30	1 1/4"W	4.0	44	65
○ 40	1 1/2"	4.5	55	82
○ 50	2"	5.0	63	96
○ 65	2 1/2"	6.6	61	110
○ 80	3"	8.0	64	120
○ 100	4"	10.0	84	153
○ 125	5"	11.0	104	188
○ 150	6"	13.0	132	230
○ 200	8"	15.0	164	288
△ 250	10"	13.0	185	326

註 / Note:

○ 符合CNS15010一般用與自來水用耐衝擊聚氯乙烯塑膠管件2022年4月新版標準(正字標誌認證)

△ 20°C使用壓力7.65kgf/cm² ↓ , 實際使用等級詳洽南亞客服人員。

○ Comply with the new version (April, 2022) of CNS 15010 standards—Unplasticized high impact Polyvinyl chloride(PVC-U) pipe fittings for general uses and water supply.

△ Below 7.65kg/cm² of hydrostatic pressure resistance(20°C).Please contact our specialist for the actual grade of materials at any time.

7

HI耐衝擊PVC-U接頭規格

Specification for HI high impact PVC-U fittings drainage

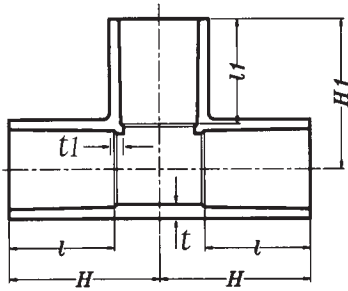

T型同徑接頭 Tee

單位 : mm

規格	Size	t	l	II	H	HI
○ 16	½"	3.5	30	30	43	43
○ 20	¾"	3.5	35	35	50	50
○ 25	1"W	4.0	40	40	58	58
○ 30	1¼"W	4.0	44	44	65	65
○ 40	1½"	4.5	55	55	82	82
○ 50	2"	5.0	63	63	96	96
○ 65	2½"	6.6	61	61	110	110
○ 80	3"	8.0	64	64	120	120
○ 100	4"	10.0	84	84	152	152
○ 125	5"	11.0	104	104	187	187
○ 150	6"	13.0	132	132	230	230
○ 200	8"	15.0	164	164	287.5	287.5
△ 250	10"	13.0	185	185	325	325

T型異徑接頭 Reducer Tee

單位 : mm

規格	Size	t	tI	l	II	H	HI
○ 20x16	¾"x½"	3.5	3.5	35	30	48	45
○ 25x16	1"Wx½"	4.0	3.5	40	30	53	48
○ 25x20	1"Wx¾"	4.0	3.5	40	35	55	53
○ 30x16	1¼"Wx½"	4.0	3.5	44	30	57	51
○ 30x20	1¼"Wx¾"	4.0	3.5	44	35	59	56
○ 30x25	1¼"Wx1"W	4.0	4.0	44	40	62	61
○ 40x16	1½"x½"	4.5	3.5	55	30	68	57
○ 40x20	1½"x¾"	4.5	3.5	55	35	70	62
○ 40x25	1½"x1"W	4.5	4.0	55	40	73	67
○ 40x30	1½"x1¼"W	4.5	4.0	55	44	76	71
○ 50x16	2"x½"	5.0	3.5	63	30	76	63
○ 50x20	2"x¾"	5.0	3.5	63	35	78	68
○ 50x25	2"x1"W	5.0	4.0	63	40	81	73
○ 50x30	2"x1¼"W	5.0	4.0	63	44	84	77
○ 50x40	2"x1½"	5.0	4.5	63	55	90	88
○ 65x40	2½"x1½"	6.6	4.5	61	55	100	96
○ 65x50	2½"x2"	6.6	5.0	61	63	101	104
○ 80x20	3"x¾"	6.0	3.5	72	35	90	82
○ 80x25	3"x1"W	8.0	4.0	64	40	93	88
○ 80x40	3"x1½"	8.0	4.5	64	55	100	102
○ 80x50	3"x2"	8.0	5.0	64	63	105	110
○ 80x65	3"x2½"	8.0	6.6	64	61	113	117
○ 100x40	4"x1½"	7.5	4.5	92	55	120	115
○ 100x50	4"x2"	10.0	5.0	84	63	125	122
○ 100x80	4"x3"	10.0	8.0	84	64	140	132
○ 125x80	5"x3"	11.0	8.0	104	64	160	147
○ 125x100	5"x4"	11.0	10.0	104	84	173	167
○ 150x80	6"x3"	13.0	8.0	132	64	195	158
○ 150x100	6"x4"	13.0	10.0	132	84	208	182
○ 150x125	6"x5"	13.0	11.0	132	104	217	201
○ 200x100	8"x4"	15.0	10.0	164	84	236.5	204
○ 200x150	8"x6"	15.0	13.0	164	132	264	252

註 / Note:

○ 符合CNS15010一般用與自來水用耐衝擊聚氯乙烯塑膠管件2022年4月新版標準(正字標誌認證)

△ 20°C使用壓力7.65kgf/cm² ↓ , 實際使用等級詳洽南亞客服人員。

○ Comply with the new version (April, 2022) of CNS 15010 standards—Unplasticized high impact Polyvinyl chloride(PVC-U) pipe fittings for general uses and water supply.

△ Below 7.65kg/cm² of hydrostatic pressure resistance(20°C).Please contact our specialist for the actual grade of materials at any time.

7

HI耐衝擊PVC-U接頭規格

Specification for HI high impact PVC-U fittings drainage

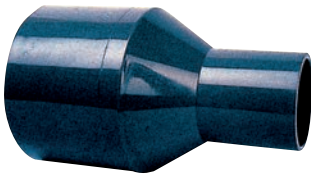
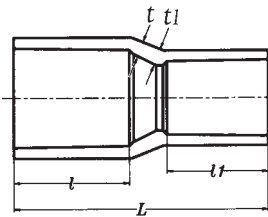
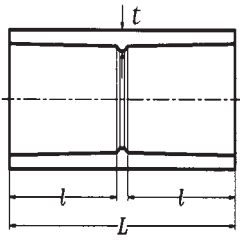

S型同徑接頭 Coupling

單位: mm

規格	Size	t	l	H
○	16 1/2"	3.5	30	67
○	20 3/4"	3.5	35	77
○	25 1"W	4.0	40	87
○	30 1 1/4"W	4.0	44	95
○	40 1 1/2"	4.5	55	117
○	50 2"	5.0	63	133
○	65 2 1/2"	6.6	61	145
○	80 3"	8.0	64	155
○	100 4"	10.0	84	200
○	125 5"	11.0	104	240
○	150 6"	13.0	132	300
○	200 8"	15.0	164	360
△	250 10"	13.0	185	400

S型異徑接頭 Reducer Coupling

單位: mm

規格	Size	t	t1	l	l1	L
○	20x16 3/4"x1/2"	3.5	3.5	35	30	71
○	25x16 1"Wx1/2"	4.0	3.5	40	30	85
○	25x20 1"Wx3/4"	4.0	3.5	40	35	84
△	28x25 1"x1"W	3.5	4.0	4.0	4.0	90
○	30x16 1 1/4"Wx1/2"	4.0	3.5	44	30	95
○	30x20 1 1/4"Wx3/4"	4.0	3.5	44	35	93
○	30x25 1 1/4"Wx1"W	4.0	4.0	44	40	93
△	35x30 1 1/4"x1 1/4"W	4.0	4.0	44	44	100
○	40x16 1 1/2"x1/2"	4.5	3.5	55	30	91
○	40x20 1 1/2"x3/4"	4.5	3.5	55	35	113
○	40x25 1 1/2"x1"W	4.5	4.0	55	40	114
○	40x30 1 1/2"x1 1/4"W	4.5	4.0	55	44	114
○	50x16 2"x1/2"	5.0	3.5	63	30	120
○	50x20 2"x3/4"	5.0	3.5	63	35	116
○	50x25 2"x1"W	5.0	4.0	63	40	140
○	50x30 2"x1 1/4"W	5.0	4.0	63	44	136
○	50x40 2"x1 1/2"	5.0	4.5	63	55	136
○	65x40 2 1/2"x1 1/2"	6.6	4.5	61	55	145
○	65x50 2 1/2"x2"	6.6	5.0	61	63	149
○	80x50 3"x2"	8.0	5.0	64	63	165
○	80x65 3"x2 1/2"	6.0	6.0	72	69	165
○	100x40 4"x1 1/2"	7.5	4.5	92	55	190
○	100x50 4"x2"	7.5	5.0	92	63	208
○	100x80 4"x3"	10.0	8.0	84	64	190
○	125x100 5"x4"	11.0	10.0	104	84	229
○	150x80 6"x3"	9.0	6.0	140	72	260
○	150x100 6"x4"	13.0	10.0	132	84	295
○	150x125 6"x5"	13.0	11.0	132	104	272
○	200x100 8"x4"	15.0	10.0	164	84	340
○	200x125 8"x5"	15.0	11.0	164	104	345
○	200x150 8"x6"	15.0	13.0	164	132	350
△	250x200 10"x8"	13.0	10.5	185	172	420
△	300x200 12"x8"	15.0	10.5	230	172	495

註 / Note:

- 符合CNS15010一般用與自來水用耐衝擊聚氯乙烯塑膠管件2022年4月新版標準(正字標誌認證)
- △ 20°C使用壓力7.65kgf/cm² ↓ , 實際使用等級詳洽南亞客服人員。
- Comply with the new version (April, 2022) of CNS 15010 standards—Unplasticized high impact Polyvinyl chloride(PVC-U) pipe fittings for general uses and water supply.
- △ Below 7.65kg/cm² of hydrostatic pressure resistance(20°C).Please contact our specialist for the actual grade of materials at any time.

7

HI耐衝擊PVC-U接頭規格

Specification for HI high impact PVC-U fittings drainage

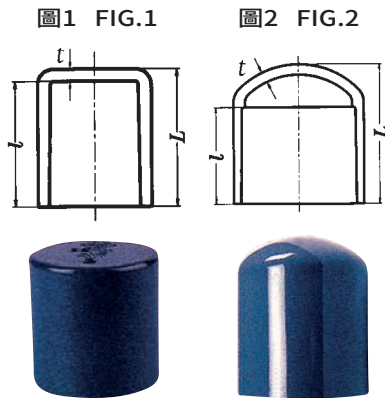

塞頭 Cap

單位: mm

規格 Size		t	l	L	
圖1 FIG.1	16	1/2"	3.5	30	33.5
	20	3/4"	3.5	35	38.5
	25	1"W	4.0	40	44
	30	1 1/4"W	4.0	44	48
	40	1 1/2"	4.5	55	59.5
圖2 FIG.2	50	2"	5.0	63	68
	65	2 1/2"	6.6	61	96
	80	3"	8.0	64	105
	100	4"	10.0	84	138
	125	5"	11.0	104	160
	150	6"	13.0	132	205
200	8"	15.0	164	257	

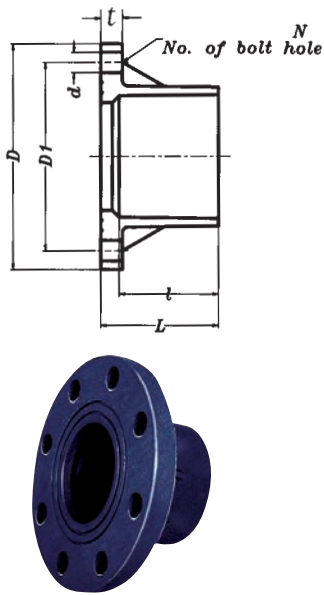

法蘭接頭 Flange

單位: mm

規格 Size	t	D	DI	l	螺孔 Hole		L	
					d	N		
40	1 1/2"	17	140	105	55	19	4	68
50	2"	17	155	120	63	19	4	76
65	2 1/2"	18	175	140	69	19	4	83
80	3"	20	185	150	72	19	8	86
100	4"	20	210	175	92	19	8	107
125	5"	20	250	210	112	23	8	130
150	6"	22	280	240	140	23	8	165
200	8"	22	330	290	172	23	12	195
250	10"	24	400	355	185	25	12	235
300	12"	30	445	400	230	25	16	295

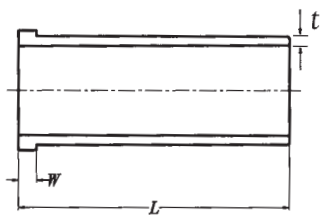

由令 Union

單位: mm

規格 Size	t	W	L	
16	1/2"	3.0	5	85
20	3/4"	3.0	6	90
25	1"W	3.5	7	100
30	1 1/4"W	3.5	8	110
40	1 1/2"	4.0	8	120
50	2"	4.5	9	130





HI耐衝擊PVC-U接頭規格

Specification for HI high impact PVC-U fittings drainage

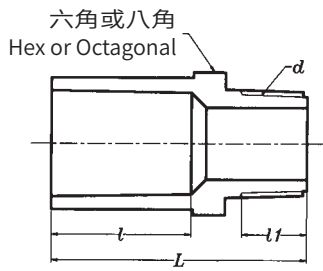

止閘接頭(塑膠牙)

Male Adapter (Plastic Thread)

單位 : mm

規格 Size		l	螺牙THREAD		L
			d	H	
16	1/2"	30	PT1/2"	15	54
20	3/4"	35	PT3/4"	17	64
25	1"W	40	PT1"	19	71
30	1 1/4"W	44	PT1 1/4"	22	80
40	1 1/2"	55	PT1 1/2"	22	92
50	2"	63	PT2"	26	106
65	2 1/2"	69	PT2 1/2"	30	120
80	3"	72	PT3"	33	126
100	4"	92	PT4"	40	146
125	5"	112	PT5"	44	177
150	6"	140	PT6"	44	213

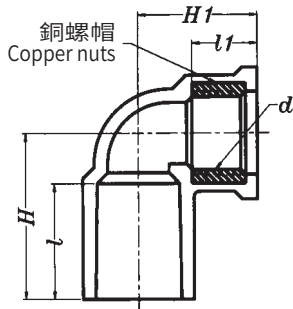

龍L入銅接頭

Faucet Fitting (Insert Bronze Nut) – 90° Elbow

單位 : mm

規格 Size		l	H	螺牙THREAD		H1
				d	H	
16	1/2"	30	43	PF1/2"	17	32
20	3/4"	35	51	PF3/4"	19	36

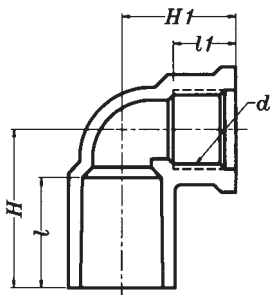

龍L接頭(塑膠牙)

Faucet Fitting (Plastic Thread) – 90° Elbow

單位 : mm

規格 Size		l	H	螺牙THREAD		H1
				d	H	
16	1/2"	30	43	PT1/2"	17	32
20	3/4"	35	51	PT3/4"	19	36

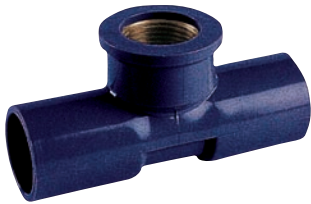
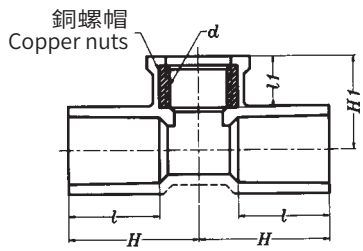

龍T入銅接頭

Faucet Fitting (Insert Bronze Nut) – Fixture Tee

單位：mm

規格 Size		l	H	螺牙THREAD		HI
				d	II	
16	1/2"	30	43	PF1/2"	17	32
20x16	3/4"x1/2"	30	47	PF1/2"	17	34
20	3/4"	35	51	PF3/4"	19	36

龍T接頭(塑膠牙)

Faucet Fitting (Plastic Thread) – Fixture Tee

單位：mm

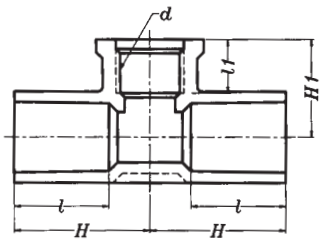

規格 Size		l	H	螺牙THREAD		HI
				d	II	
16	1/2"	30	43	PT 1/2"	17	32
20x16	3/4"x1/2"	35	47	PT 1/2"	17	34
20	3/4"	35	51	PT 3/4"	19	36

7

HI耐衝擊PVC-U接頭規格

Specification for HI high impact PVC-U fittings drainage

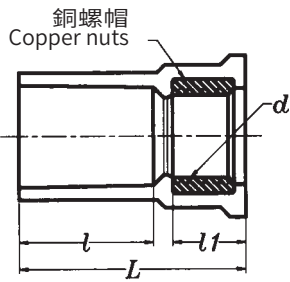

龍S入銅接頭

Faucet Fitting (Insert Bronze Nut) – Female Adapter

單位 : mm

規格 Size		<i>l</i>	螺牙THREAD		<i>L</i>
			<i>d</i>	<i>l1</i>	
16	½"	30	PF½"	17	52
20	¾"	35	PF¾"	19	59
25	1"W	40	PF1"	21	68

龍S接頭(塑膠牙)

Faucet Fitting (Plastic Thread) – Female Adapter

單位 : mm

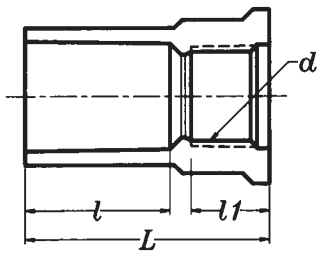

規格 Size		<i>l</i>	螺牙THREAD		<i>L</i>
			<i>d</i>	<i>l1</i>	
16	½"	30	PT½"	19	57
20	¾"	35	PT¾"	19	59

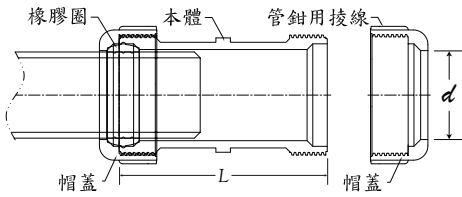

伸縮接頭 Compression Fitting

特性 Characteristics:

1. 施工簡便、容易裝卸、施工不受天候影響、施工後可立即通水、耐水壓强度高、具有伸縮效果。
 2. 適用於埋設地下管線，若用於地上配管時，伸縮接頭需予以固定住，防止滑動。
1. Compression fitting, which is easy for construction and loading without weather impact, features superb compression and water pressure resistance.
 2. Compression fitting, not only used for underground pipeline but also suitable for above-ground pipeline, needs to be fixed tightly to avoid sliding.

用途 Applications:

1. 適用於中小口徑壓力管線。
 2. 可吸收直線配管因熱脹冷縮所產生的伸縮量。
 3. 作為管線破裂後之緊急快速搶修接頭。
1. Applicable to high pressure pipeline (for small and medium size of compression fittings use).
 2. Able to absorb piping's expansion resulted from thermal expansion and contraction.
 3. Suitable for fixing damaged compression fittings of cracked pipeline.

單位：mm

規格 Size	內徑 d 及許可差 Inside Diameter and Tolerance	本體長度 L
16	1/2"	22.8 ± 0.3
20	3/4"	26.8 ± 0.3
* 25	1"W	33.0 ± 0.4
* 30	1 1/4"W	39.0 ± 0.4
* 40	1 1/2"	49.2 ± 0.4
50	2"	61.5 ± 0.5
65	2 1/2"	77.5 ± 0.5
80	3"	90.8 ± 0.5
100	4"	116.0 ± 0.6

註/Remark:

1. 橡膠圈材質依CNS 10774之I類A5之規定。
 2. * 表示模具開發中。
 3. 伸縮接頭施工方式請詳閱PVC-U管施工應注意事項第13項(Page 31)。
1. The rubber ring material is in accordance with the A5 of Class I in CNS 10774.
 2. * Means the mold is developing.
 3. Compression coupling construction method, please read the notice items for PVC-U piping instructions, item 13 (Page 31).

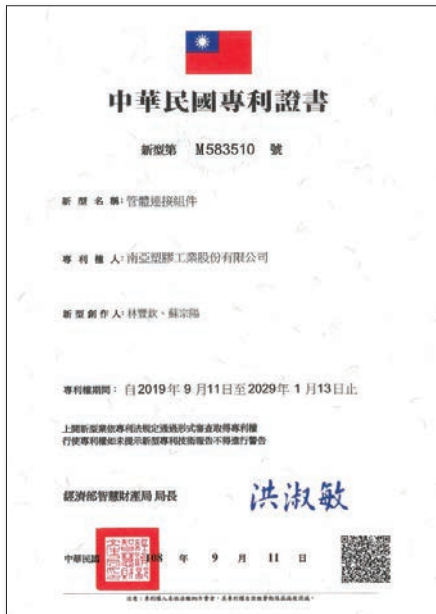
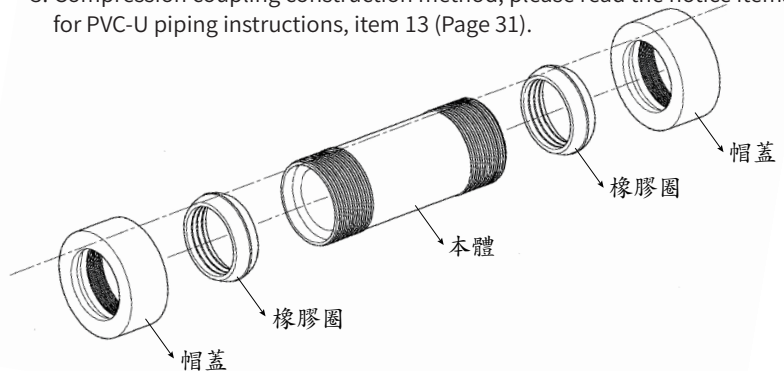

7

HI耐衝擊PVC-U接頭規格

Specification for HI high impact PVC-U fittings drainage

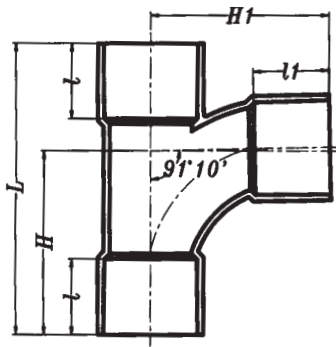

順T接頭 Sanitary Tee

單位：mm

規格	Size	<i>l</i>	<i>l1</i>	<i>H</i>	<i>H1</i>	<i>L</i>
80X50	3"X2"	72	63	140	145	235
100X50	4"X2"	92	63	154	152	270

註：

順T接頭限用於無壓力之排水。

Note:

Sanitary T fitting is used for non-pressuer drainage.

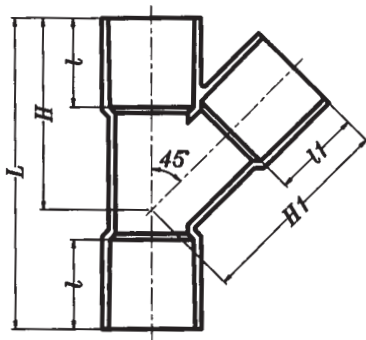

同徑Y型接頭 Wye

單位：mm

規格	Size	<i>l</i>	<i>l1</i>	<i>H</i>	<i>H1</i>	<i>L</i>
50	2"	63	141	142	220	200
80	3"	72	180	188	280	235
100	4"	92	92	230	240	355
125	5"	112	112	282	292	434
150	6"	140	140	344	352	530

異徑Y型接頭 Reducer Wye

單位：mm

規格	Size	<i>l</i>	<i>l1</i>	<i>H</i>	<i>H1</i>	<i>L</i>
80X50	3"X2"	72	63	164	164	239
100X50	4"X2"	92	63	195	185	285
100X80	4"X3"	92	72	213	202	319
125X50	5"X2"	112	63	233	192	337
125X80	5"X3"	112	72	252	216	372
125X100	5"X4"	112	92	272	252	415
150X50	6"X2"	140	63	270	228	385
150X80	6"X3"	130	72	282	240	412
150X100	6"X4"	130	92	294	274	435
150X125	6"X5"	140	112	322	310	500

註：

Y型接頭限用於無壓力之排水。

Note:

Wye type fitting is used for non-pressuer drainage.

7

HI耐衝擊PVC-U接頭規格

Specification for HI high impact PVC-U fittings drainage

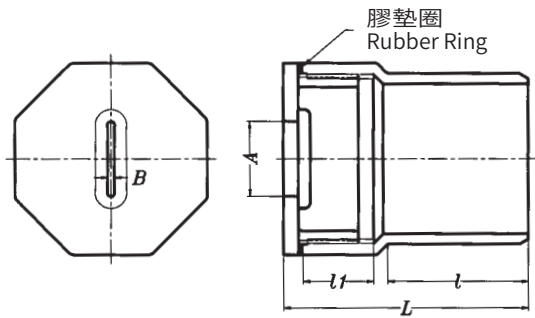

清除孔接頭 Cleanout Bushing

單位: mm

規格 Size	A	B	L	L1	L
50 2"	30	4.5	59	25	98
125 5"	80	10	120	50	194

註:

- 1.清除孔接頭本體與蓋之間所套入橡膠墊圈，於每次使用後應鎖緊，以防漏水。
- 2.清除孔接頭限用於無壓力之排水。

Note:

- 1.In order to against the leakage of rubber ring between cleanout bushing body and cap, please screw the cleanout cap on the cleanout bushing body tightly.
- 2.cleanout bushing is used for non-pressuer drainage.

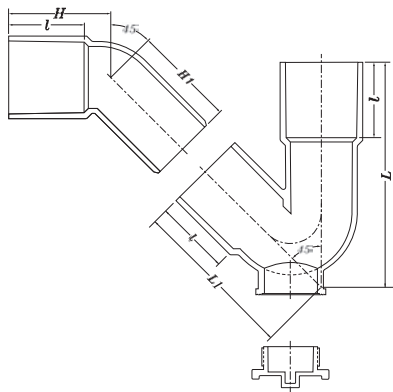

P型存水接頭

"P" Trap with Solvent Weldjoint And Cleanout Plug

單位: mm

規格 Size	L	H	L1	H1	L
2"X4mm (1¾內大牙)	63	85	138	85	195

註:

P型存水接頭限用於無壓力之排水。

Note:

It is used for non-pressuer drainage.

8

下水道及排水用接頭規格

Specification of PVC-U Fittings for Sewerage & Drainage

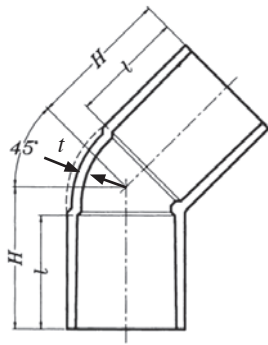

45° L型接頭 45° Elbow

單位：mm

規格	Size	t	l	H
40	1 1/2"	4.5	55	69
50	2"	5.0	63	80
65	2 1/2"	5.0	69	90
80	3"	6.0	72	95
90	3 1/2"	6.5	80	105
100	4"	7.5	92	121
125	5"	8.0	112	150
150	6"	9.0	140	185
200	8"	10.5	172	224
250	10"	13.0	185	248

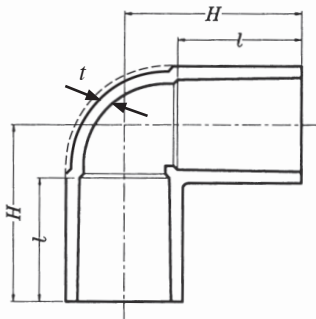

90° L型接頭 90° Elbow

單位：mm

規格	Size	t	l	H
40	1 1/2"	4.5	55	82
50	2"	5.0	63	96
65	2 1/2"	5.0	69	110
80	3"	6.0	72	120
90	3 1/2"	6.5	80	135
100	4"	7.5	92	152
125	5"	8.0	112	188
150	6"	9.0	140	228
200	8"	10.5	172	288
250	10"	13.0	185	326

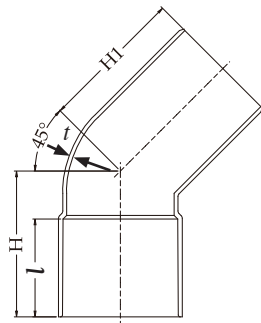

45° L型單放口接頭

45° Elbow With Spigot End

單位：mm

規格	Size	t	l	H	H1
40	1 1/2"	4.5	55	69	69
50	2"	4.0	63	85	85
80	3"	5.5	72	95	95
100	4"	7.0	92	121	121
125	5"	7.5	112	148	148

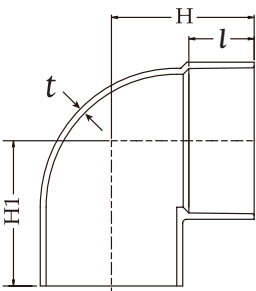

90° L型單放口接頭

90° Elbow with Spigot End

單位：mm

規格	Size	厚接頭(90° OL) Thick				薄接頭(90° 排L) Thin			
		t	l	H	H1	t	l	H	H1
40	1 1/2"	4.5	55	82	85				
50	2"	4.0	63	96	101	2.0	25	57	58.5
100	4"	7.0	92	152	159.5	3.5	50	110	114

註/Note :

亦可參照灰色一般用接頭規格訂製橘色成品

Production can be manufactured by specification of gray fitting, only change color.

8

下水道及排水用接頭規格

Specification of PVC-U Fittings for Sewerage & Drainage

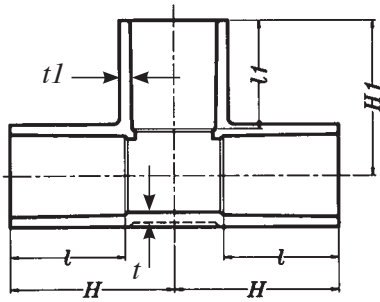

T型接頭 Tee

單位: mm

規格 Size	t	tI	l	II	H	HI
40X40 1 1/2"	4.5	4.5	55	55	82	82
50X50 2"	5.0	5.0	63	63	96	96
65X50 2 1/2"X2"	5.0	5.0	69	63	102	104
80X50 3"X2"	6.0	5.0a	72	63	105	110
100X50 4"X2"	7.5	4.5	92	63	125	122
100X80 4"X3"	7.5	6.0	92	72	140	132
100X100 4"	7.5	7.5	92	92	152	152

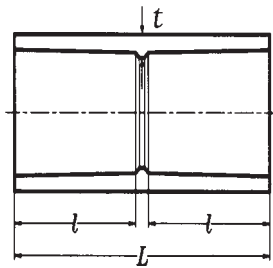

同徑普通接頭 Coupling

單位: mm

規格 Size	t	l	L
40 1 1/2"	4.5	55	117
50 2"	5.0	63	133
65 2 1/2"	6.6	69	147
80 3"	6.0	72	155
100 4"	7.5	92	200
125 5"	8.0	112	235
150 6"	9.0	140	300
200 8"	10.5	172	360
250 10"	13.0	185	400

註/Note :

亦可參照灰色一般用接頭規格訂製橘色成品

Production can be manufactured by specification of gray fitting, only change color.

8

下水道及排水用接頭規格

Specification of PVC-U Fittings for Sewerage & Drainage

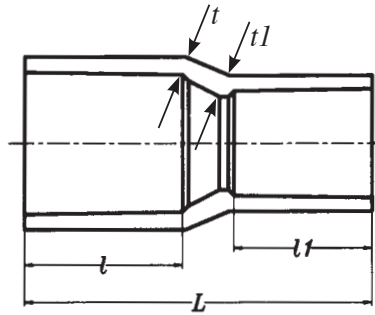

異徑普通接頭 Reducer Coupling 單位: mm

規格 Size	t	t1	l	l1	L
50X40 2"X1 1/2"	5.0	3.5	63	55	136
65X40 2 1/2"X1 1/2"	5.0	4.0	69	55	150
65X50 2 1/2"X2"	5.0	4.5	69	63	153
80X50 3"X2"	6.0	4.5	72	63	165
100X50 4"X2"	7.5	5.0	92	63	208
100X80 4"X3"	10.0	8.0	92	72	190
125X80 5"X3"	8.0	7.5	112	72	210
125X100 5"X4"	8.0	7.5	112	92	225
150X80 6"X3"	9.0	6.0	140	72	260
150X100 6"X4"	9.0	7.5	140	92	280
150X125 6"X5"	9.0	8.0	140	112	295
200X100 8"X4"	10.5	7.5	172	92	340
200X125 8"X5"	10.5	8.0	172	112	345
200X150 8"X6"	10.5	9.0	172	140	350
250X200 10"X8"	13.0	10.5	185	172	420

圖1 FIG.1

圖2 FIG.2

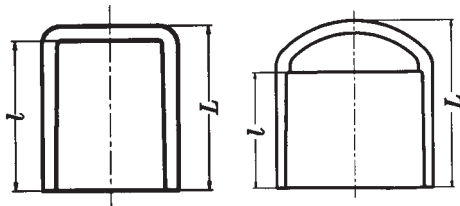

塞頭 Cap

單位: mm

規格 Size	l	L	備註 Remark
40 1 1/2"	55	59.5	圖1 FIG.1
50 2"	63	68	圖1 FIG.1
80 3"	72	107	圖2 FIG.2
100 4"	92	138	圖2 FIG.2
125 5"	112	168	圖2 FIG.2
150 6"	140	205	圖2 FIG.2
200 8"	172	260	圖2 FIG.2

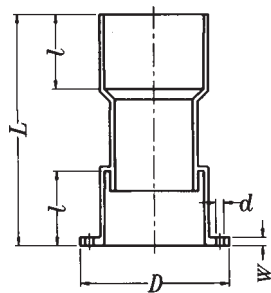

樓板接頭 Slab Joint

單位: mm

規格 Size	D	d	W	l	L
40 1 1/2"	52.5	3.5	5	40	140
50 2"	65	3.5	5	45	140
80 3"	96	3.5	5	50	140
80x65x50 3"x2 1/2"x2"	96	3.5	5	40	140
100 4"	122	3.5	5	50	140

註/Note :

亦可參照灰色一般用接頭規格訂製橘色成品

Production can be manufactured by specification of gray fitting, only change color.

8

下水道及排水用接頭規格

Specification of PVC-U Fittings for Sewerage & Drainage

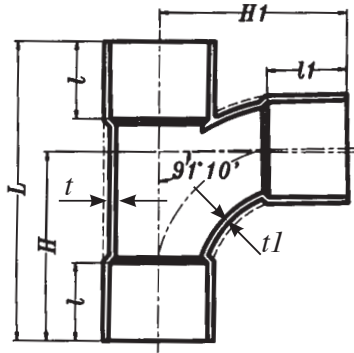

順T接頭 Sanitary Tee

單位: mm

規格 Size	t	t1	l	l1	H	H1	L
40X40 1 1/2"	4.5	4.5	55	55	111	111	180
50X40 2"X1 1/2"	5.0	4.5	63	55	114	118	192
50X50 2"	5.0	5.0	63	63	114	127	200
65X50 2 1/2"X2"	5.0	5.0	69	63	128	130	218
65X65 2 1/2"	5.0	5.0	69	69	132	140	234
80X50 3"X2"	6.0	5.0	72	63	140	145	235
80X80 3"	6.0	6.0	72	72	177	172	280
100X50 4"X2"	7.5	5.0	92	63	154	152	270
100X80 4"X3"	7.5	6.0	92	72	194	182	318
100X100 4"	7.5	7.5	92	92	224	219	355
125X80 5"X3"	8.0	6.0	112	72	235	198	350
125X100 5"X4"	8.0	7.5	112	92	235	219	388
125X125 5"	8.0	8.0	112	112	252	233	416
150X50 6"X2"	9.0	5.0	140	63	215	180	420
150X80 6"X3"	9.0	6.0	130	72	230	207	420
150X100 6"X4"	9.0	7.5	130	92	246	234	425
150X125 6"X5"	9.0	8.0	140	112	273	252	468
150X150 6"	9.0	9.0	140	140	290	295	495
200X80 8"X3"	10.5	6.0	172	72	265	235	470
200X100 8"X4"	10.5	7.5	172	92	262	263	510
200X150 8"X6"	10.5	9.0	172	140	307	320	560
200X200 8"	10.5	10.5	172	172	347	360	615

45° Y型接頭 45° Wye

單位: mm

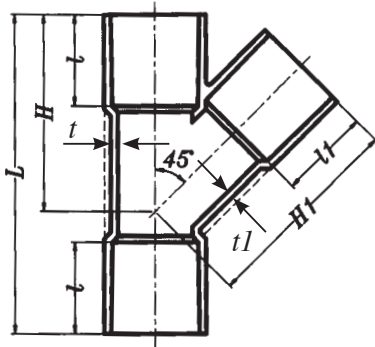

規格 Size	t	t1	l	l1	H	H1	L
40X40 1 1/2"	4.5	4.5	55	55	116	119	185
50X40 2"X1 1/2"	5.0	4.5	63	55	132	128	202
50X50 2"	5.0	5.0	63	63	141	142	220
65X50 2 1/2"X2"	5.0	5.0	69	63	148	152	230
80X50 3"X2"	6.0	5.0	72	63	164	164	239
80X80 3"	6.0	6.0	72	72	188	188	280
100X50 4"X2"	7.5	5.0	92	63	195	185	285
100X80 4"X3"	7.5	6.0	92	72	213	202	319
100X100 4"	7.5	7.5	92	92	230	240	355
125X50 5"X2"	8.0	5.0	112	63	233	192	337
125X80 5"X3"	8.0	6.0	112	72	252	216	372
125X100 5"X4"	8.0	7.5	112	92	272	252	415
125X125 5"	8.0	8.0	112	112	282	292	434
150X50 6"X2"	9.0	5.0	140	63	270	228	385
150X80 6"X3"	9.0	6.0	130	72	282	240	412
150X100 6"X4"	9.0	7.5	130	92	294	274	435
150X125 6"X5"	9.0	8.0	140	112	322	310	500
150X150 6"	9.0	9.0	140	140	344	352	530
200X50 8"X2"	10.5	5.0	172	63	327	258	445
200X80 8"X3"	10.5	6.0	172	72	345	282	485
200X100 8"X4"	10.5	7.5	172	92	362	316	520
200X125 8"X5"	10.5	8.0	172	112	382	349	560
200X150 8"X6"	10.5	9.0	172	140	400	394	600
200X200 8"	10.5	10.5	172	172	446	433	690
250X150 10"X6"	13.0	9.0	185	140	450	430	625

註/Note :

亦可參照灰色一般用接頭規格訂製橘色成品

Production can be manufactured by specification of gray fitting, only change color.

8

下水道及排水用接頭規格

Specification of PVC-U Fittings for Sewerage & Drainage

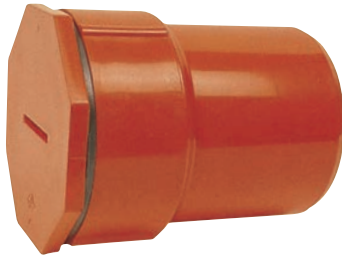
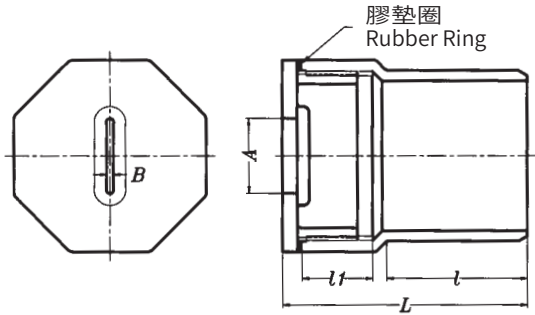

清除孔接頭 Cleanout Bushing

單位: mm

規格 Size	A	B	l	II	L
50 2"	30	4.5	59	25	98
80 3"	50	4.5	75	38	131
100 4"	50	4.5	93	47	164
125 5"	80	10	120	50	194
150 6"	125	10	128	50	204
200 8"	160	10	175	50	255

註/Note:

清除孔接頭本體與蓋之間所套入橡膠墊圈，於每次使用後應鎖緊，以防漏水。

In order to against the leakage of rubber ring between cleanout bushing body and cap, please screw the cleanout cap on the cleanout bushing body tightly.

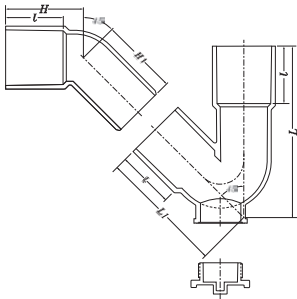

P 型存水接頭

"P" Trap with Solvent Weldjoint And Cleanout Plug

單位: mm

規格 Size	l	H	II	H1	L
1 1/2"X2mm(1 1/4"內大牙)	22	37	80	37	102
2"X2mm(1 3/4"內大牙)	25	50	100	75.5	137
2"X4mm(1 3/4"內大牙)	63	85	138	85	195

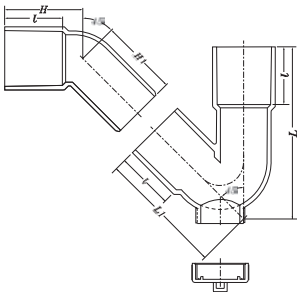

單位: mm

規格 Size	l	H	II	H1	L
1 1/2"X2mm(1 1/4"外大牙)	22	37	80	37	102
2"X2mm(1 3/4"外大牙)	25	50	100	75.5	137
2"X4mm(1 3/4"外大牙)	63	85	138	85	195

8

下水道及排水用接頭規格

Specification of PVC-U Fittings for Sewerage & Drainage

V型存水接頭 V Type Water Connection

單位 : mm

規格 Size	<i>l</i>	<i>LI</i>	<i>H</i>	<i>HI</i>
2"X4m	63	63	85	85

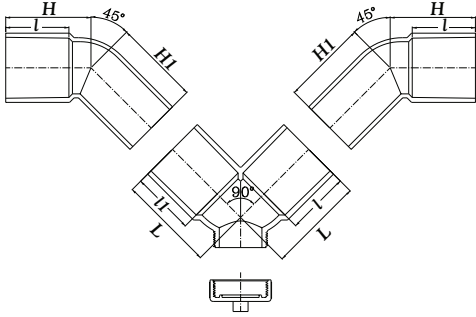

污水防臭接頭 本體 Junction with Odor Trap

單位 : mm

規格 Size	<i>H</i>	<i>L</i>	<i>l</i>	<i>II</i>	<i>I2</i>
(A型) 100x150 4"X6"	398	457	234.5	140	92
(B型) 100x150 4"X6"	305	402	234.5	50	50

A型:
TYPE A

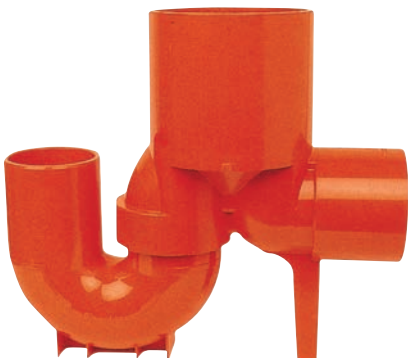
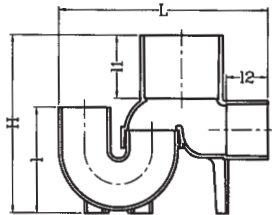
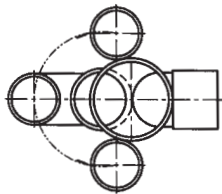

B型:
TYPE B

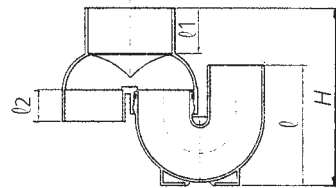
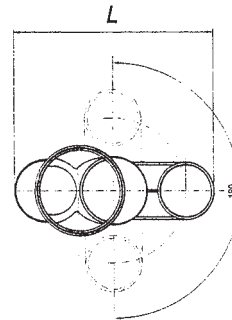

8

下水道及排水用接頭規格

Specification of PVC-U Fittings for Sewerage & Drainage



45YS-UT



單接糞管及存水彎側通匯流井 45° Confluence with Trap

型號	標稱管徑(mm)			
	用戶接管	匯流管	豎井	TSS規格
45YS-UT(右) 100x80SX100-150	100x80S	100	150	●
45YS-UT(右) 100x80PX100-150	100x80P	100	150	●
45YS-UT(左) 100x80SX100-150	100x80S	100	150	●
45YS-UT(左) 100x80PX100-150	100x80P	100	150	●

註：1. 80存水彎末尾S者，其接管端為承口型，末尾P者，其接管端為插口型。
2. 存水彎可視配管需要旋轉調整角度。



HYS

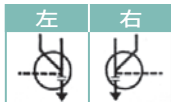

單接糞管側通匯流井 Parallel and 90° Confluence

型號	標稱管徑(mm)			
	用戶接管	匯流管	豎井	TSS規格
HYS(右) 100x100-150	100	100	150	●
HYS(左) 100x100-150	100	100	150	●

註：45° L承口可視配管需要旋轉調整角度。



UTW



雙接存水彎匯流井 Double Access Trap

型號	標稱管徑(mm)			
	用戶接管	匯流管	豎井	TSS規格
UTW(右) 80Sx80SX100-150	80Sx80S	100	150	●
UTW(右) 80Px80PX100-150	80Px80P	100	150	●
UTW(左) 80Sx80SX100-150	80Sx80S	100	150	●
UTW(左) 80Px80PX100-150	80Px80P	100	150	●

註：1. 80存水彎末尾S者，其接管端為承口型，末尾P者，其接管端為插口型。
2. 存水彎可視配管需要旋轉調整角度。



90L



90° 彎管匯流井 90° Turn

型號	標稱管徑(mm)			
	用戶接管	匯流管	豎井	TSS規格
90° L(右)100-150	—	100	150	●
90° L(左)100-150	—	100	150	●

8

下水道及排水用接頭規格

Specification of PVC-U Fittings for Sewerage & Drainage



單接存水彎匯流井 Single Access Trap

型號	標稱管徑(mm)			
	用戶接管	匯流管	豎井	TSS規格
UT(右) 100X100-150	100	100	150	●
UT(左) 100X100-150	100	100	150	●

註：存水彎可視配管需要旋轉調整角度。

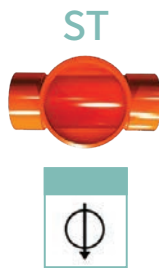
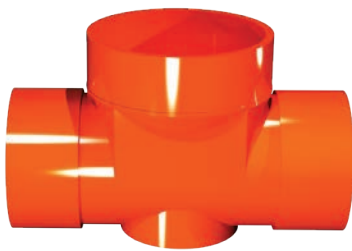

直型匯流井 Straight

型號	標稱管徑(mm)			
	用戶接管	匯流管	豎井	TSS規格
ST 100-150	—	100	150	●



兩側合流匯流井 Left and Right Confluence

型號	標稱管徑(mm)			
	用戶接管	匯流管	豎井	TSS規格
WLS 100-150	—	100	150	●

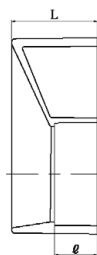

異徑轉接頭 Adapter

單位：mm

規格	L	e
80x50	25	40
100x50	25	50
100x80	40	50

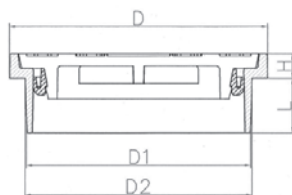

匯流井蓋 Chamber Cover

單位：mm

規格	D	D1	D2	L	H
100	114	99	100.2	24	11
150	165	145	146.5	35	16

9 南亞硬質膠合劑

Nan Ya Vinyl Adhesive

一、產品用途：

1. 硬質PVC-U管與PVC-U管之接合。
2. 硬質PVC-U管與PVC-U接頭配件之接合。

二、產品特色：

1. 對於硬質PVC-U材質接著性佳，耐低溫-10°C以上不結凍。
2. 產品具有QR CODE真偽辨識系統，掃描後可獲取該批硬膠檢驗報告(CoA)資料。
3. 施工簡便乾燥速度快，接著性佳。

三、硬膠使用選擇說明：

1. 6吋以下PVC-U管粘著使用一般硬膠ASAA(黏度80~100CPS)。
2. 6~12吋PVC-U管粘著建議使用高黏度硬膠ASAE(黏度1600CPS以上)。
3. 12吋以上管徑管件間隙較大，施工粘著時務必經多次塗佈，一定要將管件間隙完全填滿膠，方可確保無施工異常發生。
4. 管線粘著施工期間不能移動，依CNS規範常溫經時24小時後即可通水。低溫5°C以下需經時48小時後再通水。

**給水管有耐壓需求應依實務需求執行水壓測試正常後，再大範圍施作或覆蓋水泥。

I. Applications :

1. Gluing rigid PVC-U pipes.
2. Gluing rigid PVC-U pipe and PVC-U fitting.

II. Characteristics :

1. Superb adhesion with rigid PVC-U materials; cold resistance (not freezing above -10°C).
2. Available information (CoA) by scanning QR Code, the anti-fake identification system.
3. Easy for construction; quick-drying after installation.

III. Remarks :

1. Gluing PVC-U pipe (Size: below 6 inches) with ASAA vinyl adhesive (Viscosity: 80~100CPS).
2. Gluing PVC-U pipe (Size: 6~12 inches) with ASAE vinyl adhesive (Viscosity: above 1600CPS).
3. To ensure that nothing happened during PVC-U piping projects (Pipe size: above 12 inches), please glue PVC-U pipes over and over again with vinyl adhesive until there is not any gap in pipes.
4. Do not move the pipeline during the construction. Besides, according to CNS standards, it is suggested that water be transferred after 24 hours at normal temperature or after 48 hours at 5°C.

**To meet the requirement of pressure resistance, water supply pipe should pass the hydrostatic test before cement covering.



9 南亞耐衝擊PVC-U膠合劑

Nan Ya High Impact Vinyl Adhesive

一、產品用途：

1. 硬質耐衝擊PVC-U管與耐衝擊PVC-U管之接合。
2. 硬質耐衝擊PVC-U管與耐衝擊PVC-U接頭配件之接合。

二、產品特色：

1. 硬質耐衝擊PVC-U材質接著性佳，可達到CNS14345接合部耐水壓要求。
2. 施工簡便乾燥速度快，接著性佳。

三、耐衝擊PVC-U膠合劑使用選擇說明：

1. 本製品適用於6吋以下耐衝擊PVC-U管粘著使用(黏度200~1000CPS)。
2. 6吋以上管徑管件間隙較大，施工粘著時務必經多次塗佈，一定要將管件間隙完全填滿膠，方可確保無施工異常發生。建議最大管徑不要超過16吋。
3. 管線粘著施工期間不能移動，依CNS規範常溫經時24小時後即可通水低溫5°C以下需經時48小時後再通水。

**給水管有耐壓需求應依實務需求執行水壓測試正常後，再大範圍施作或覆蓋水泥。

I. Applications :

1. Gluing high impact PVC-U pipes
2. Gluing high impact PVC-U pipe and PVC-U fitting.

II. Characteristics :

1. Superb adhesion with high impact PVC-U materials in compliance with CNS 1345 Standards— water-resistant joints.
2. Easy for construction; quick-drying after installation.

III. Remarks :

1. Applicable to glue high impact PVC-U pipe (Size: below 6 inches) with high impact vinyl adhesive (Viscosity: 200~1000CPS).
2. To ensure that nothing happened during PVC-U piping projects (Pipe size: above 6 inches), please glue PVC-U pipes over and over again with high impact vinyl adhesive until there is not any gap in pipes. Therefore, it is suggested that the pipe size of high impact PVC-U pipe be less than 16 inches.
3. Do not move the pipeline during the construction. Besides, according to CNS standards, it is suggested that water be transferred after 24 hours at normal temperature or after 48 hours at 5°C.

** To meet the requirement of pressure resistance, water supply pipe should pass the hydrostatic test before cement covering.



10 管理標準化 Standardization of Management

· 徹底化、標準化管理

Thorough, Standardized Management

促使產品品質均一化，不因機台變動或人員更換而影響產品品質。

Without being impacted by substitution of equipment or staff, product quality can remain stable and good.



原料計量
Dosing equipment



原料混合
Mixing equipment



押出機
Extruder



押出模具
Extrusion die set



真空水槽
Vacuum tank

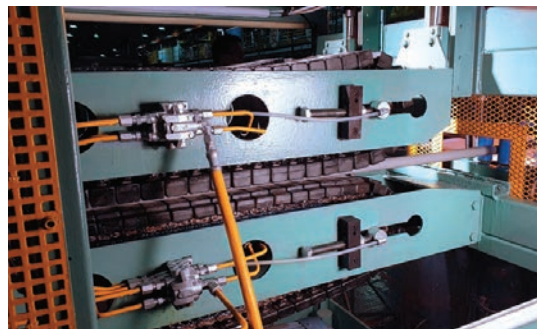

引取機
Haul-off equipment



11 生產自動化 Automated Production

- 工廠全面自動化生產
Fully Automated Production of Factory



南亞台灣管材廠
Nan Ya PVC-U Pipe Factory in Taiwan

· 產品特色 Features of Our Products

種類繁多
Diverse Categories

規格齊全
Complete Specifications

持續研發
Persistent Research & Development

品質優良
High Quality

大量生產
Mass Production

價格合理
Reasonable Price

以客為尊
Customer-oriented

永續經營
Sustainable Operation

12 品管制度化 Institutionalized Quality

· 品質政策 / Quality Policy

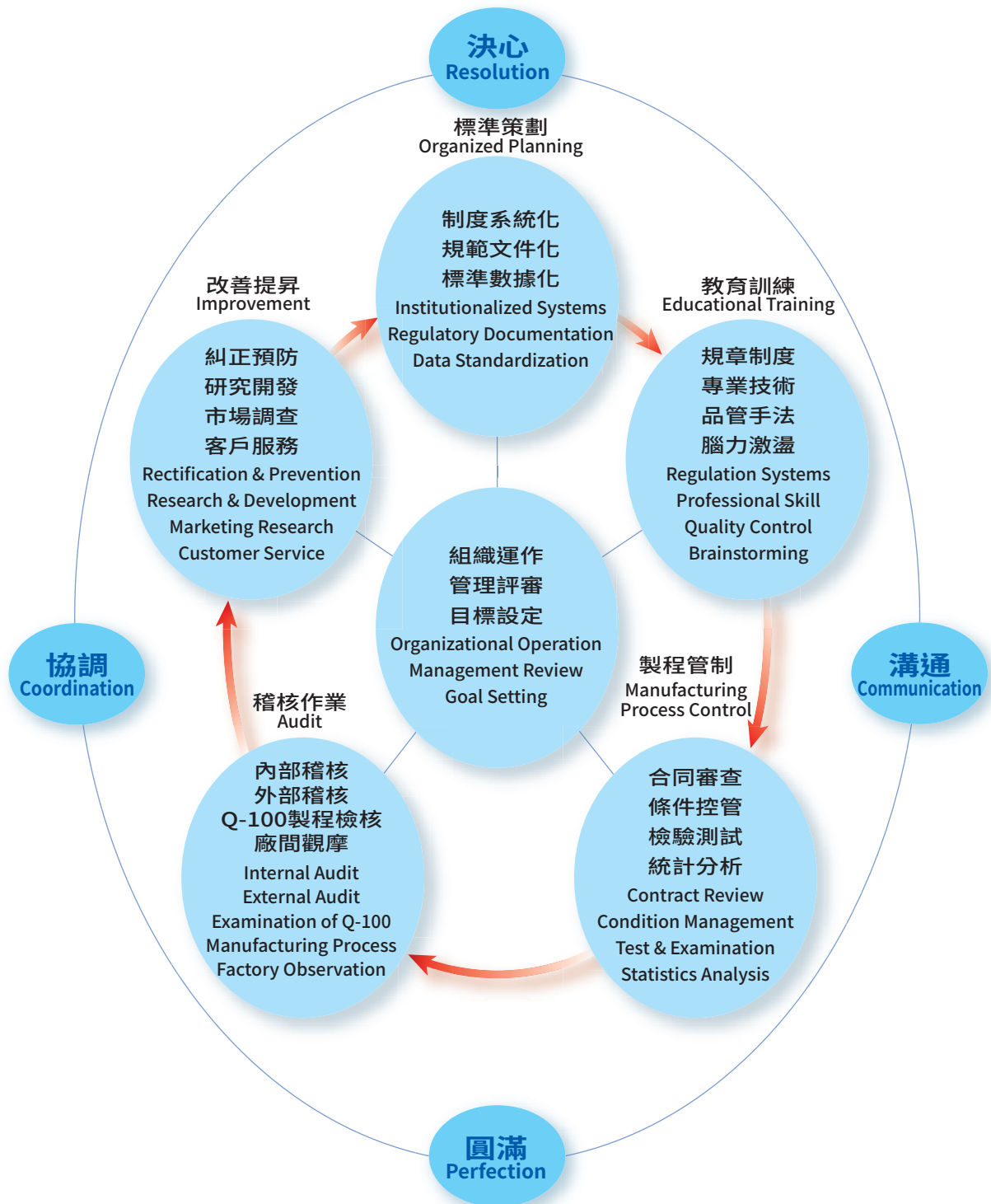

12 品管制度化 Institutionalized Quality Control



塑譜儀
Brabender



水壓試驗機
Hydrostatic Pressure Testing Machine

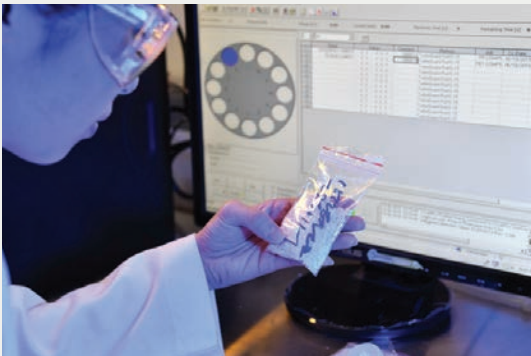

石墨爐原子吸收光譜儀
Atomic Absorption(AA)



Head space—氣相色層分析儀
Gas Chromatography (GC)

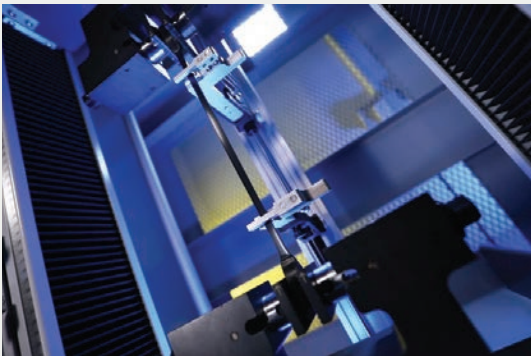

萬能拉力機
Universal Testing Machine



衝擊試驗機
Impact Testing Machine



管體剪斷試驗
Cutting Test for PVC-U Pipe

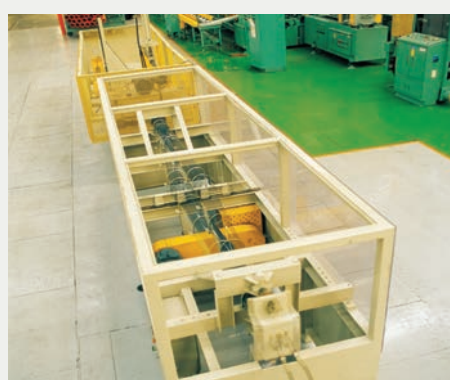

靜水壓重複彎曲試驗
Flexural Test for Hydrostatic Pressure

13 品質認證證書 Certification

ISO 9001 品質認證合格證書

ISO 9001 Quality Certification



ISO 14001 品質認證合格證書 ISO 14001 quality certification



13 品質認證證書

Certification

各項 CNS 產品通過正字標記認證證書

CNS Marks of All Products

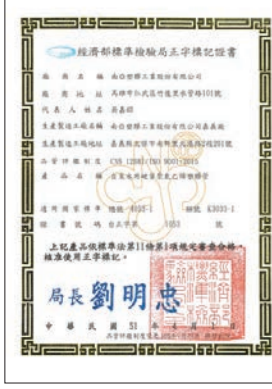



南亞塑膠工業股份有限公司
NAN YA PLASTICS CORPORATION

塑膠第三事業部 · PLASTICS 3rd DIV.

台北市南京東路六段380號(台塑企業內湖大樓A1棟2樓)

電話TEL : +886-2-2717-8230 FAX : +886-2-25140628

(2F, BUILDING A1, T.CBD) NO.380, SEC.6, NANJING E. RD., TAIPEI



南亞塑膠公司網站



南亞硬管網站

本說明書中所列試驗數據、尺寸及圖片僅供參考，以正式報告為準。

Test data, sizes, and pictures in the catalog are for reference only,
and actual product information is based on the formal reports.

(綜合本 2023. 11)