

# 耕芯股份有限公司

FERRICO CORPORATION



FERRICO

## FERRITE CORE

鐵 氧 體 磁 芯

IATF16949 / ISO9001 / ISO14001



耕芯股份有限公司  
FERRICO CORPORATION

本公司為鎳鋅系鐵氧體磁芯專業製造廠家，1987年成立於臺灣桃園，並在廣州和昆山各有一個工廠。產品主要應用於抑制雜訊、抗電磁干擾（EMI）及小型薄型(SMD)電感器，採用先進和自動化的生產設備及高精度測試儀器，並以人性化管理及持續不斷創新。

通過ISO9001、ISO14001與IATF16949等多項認證，多年來與全球知名企業合作且深獲好評與肯定。

We are a professional Ni-Zn ferrite core manufacturer, set up in Taoyuan, Taiwan in 1987, there are two factories located in Guangzhou and Kunshan, China. Our products are used for noise suppression (EMI) function and small & thin power inductors (SMD). We have advanced and high technology equipments and testing instruments, manger under high technology mode and to keep innovation is our impetus.





Our quality system under ISO9001, ISO14001 & IATF16949 Certificate, we co-operate with the famous companies in the world for many years and win high praise from them.







当社はニッケルジंकフェライトコアの専門メーカーです,1987年に台湾桃園に本社を創立され,広州と昆山にそれぞれ一つの工場があります。フェライトコアは主にノイズ抑制,電磁抵抗(EMI)及び小型薄いインダクタ(SMD)に用いられており,先進的で自動化された生産設備と高精度測定機器を採用し,人間的な管理と継続的な革新に拘り続けます。







ISO9001,ISO14001,IATF16949などの認証を取得し、長年に渡って,世界的に有名な企業と提携し良く評価されております。





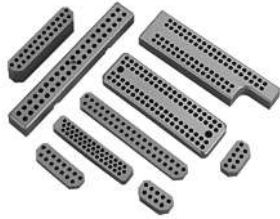

CHARACTERISTICS OF MATERIALS..... I ~XXII

SHAPE	TYPE	USE	PAGE
	BF:AT/RT	The tapping ferrite bead cores are produced for the automatic insertion into the PC board.	1~6
	FF	EMI suppression generated from flat cable used in digital equipment.	7~13
	FFS	EMI suppression generated from flat cable used in digital equipment.	14~15
	NF	EMI suppression generated from round cable used in digital equipment.	16~18
	NFR	EMI suppression generated from round cable used in digital equipment.	19~20
	NFU	EMI suppression generated from round cable used in digital equipment.	21
	NFT	EMI suppression generated from round cable used in digital equipment.	22~23

SHAPE	TYPE	USE	PAGE
	NFC	EMI suppression generated from round cable used in digital equipment.	24~25
	RH	EMI suppression generated from round cable used in digital equipment.	26~30
	T	EMI suppression generated from round cable used in digital equipment.	31~35
	R	Fixed inductors.	36
	RWW	Choke coils, peaking coils.	37
	RID	Magnetic shields for RF coils; low loss magnetic shields. BALUN coils.	38
	RHH R4H R6H	For noise-proof, on-board components of Personal computer word processor, facsimile and other digital equipment.	39

SHAPE	TYPE	USE	PAGE
	SPMF	For data line noise on PCB.	40~41
	SH	For noise-proof, on-board components of Personal computer word processor, facsimile and other digital equipment.	42
	MJ	For the connector of the telephone.	43
	DS	For noise-proof, D-SUB type connectors for projector, motor, etc.	44~45
	DIR	Low resistance high Q for chip coils.	46~47
	DR	Power inductors.	48
	DR(D31) DR(D29)	Choke coils, peaking coils.	49~50

SHAPE	TYPE	USE	PAGE
	DR& RI	Magnetic shield type cores for low profile SMD inductors.	51~56
	DI2	Double Side Low Resistance Cores For Value of Inductance.	57
	P	Used in a variety of switches.	58
	OTHER		59

Other various shapes are available. Please contact us with your requested shapes and applications.

# CHARACTERISTICS OF MATERIAL

NO.	Material	Initial Permeability (@B < 0.25 mT)	Relative Loss Factor (@ frequency)	Temp. Factor of initial Permeability (20~70°C)	Curie Temperature	Saturation Flux Density	Residual Flux Density	Coercive Force	Resistivity	Material' s feature
		$\mu_i$ $\pm 25\%$	$\tan \delta / \mu_i$ $10^{-6}$ [MHz]	$\alpha \mu_{ir}$ $\times 10^{-6}/^{\circ}\text{C}$	Tc $^{\circ}\text{C}$	Bs mT	Br mT	Hc A/m	$\rho$ $\Omega\text{-m}$	
1	F20D	2000	15[0.1]	5	>110	280 (2400A/m)	200	10	$10^6$	High permeability
2	F6	1500	20[0.1]	3	>90	250 (2400A/m)	120	20	$10^6$	High permeability
3	K15	1500	20[0.1]	8	>90	230 (3200A/m)	200	10	$10^6$	High permeability
4	F12D	1200	10[0.1]	13	>160	360 (4000A/m)	240	10	$10^6$	Low loss
5	F1K	1000	10[0.1]	5	>150	310 (2800A/m)	140	32	$10^6$	general purpose
6	F8T	800	10[0.1]	-1~1	>130	320 (4000A/m)	200	20	$10^6$	Low temperature coefficient
7	T4A	800	20[0.1]	20	>160	310 (2400A/m)	200	52	$10^6$	general purpose
8	K3	800	30[0.1]	15	>110	250 (2400A/m)	140	28	$10^6$	general purpose
9	K1	650	35[0.1]	40	>120	260 (1600A/m)	180	28	$10^6$	general purpose
10	F5H	500	15[0.1]	15	>200	380 (4000A/m)	200	48	$10^6$	Thermal shock resistance
11	F5T	500	45[0.1]	0~1	>200	360 (4000A/m)	240	50	$10^6$	Low temperature coefficient
12	F4	400	30[0.3]	30	>240	440 (4400A/m)	330	32	$10^6$	High Bs
13	F4T	400	30[0.1]	0~1	>160	290 (1600A/m)	140	50	$10^6$	Low temperature coefficient
14	J02	250	30[0.1]	20	>300	460 (6000A/m)	310	60	$10^6$	High Bs
15	F2D	250	40[0.1]	26	>180	270 (2400A/m)	190	64	$10^6$	general purpose
16	X26	120	30[0.1]	30	>200	300 (2400A/m)	200	160	$10^6$	High Q
17	F1	100	40[0.3]	50	>300	450 (6000A/m)	350	80	$10^6$	High Bs
18	X24	65	70[0.3]	45	>300	300 (2800A/m)	240	300	$10^6$	High Q

## RoHS Compliance

(EU)/2015/863

# F<sub>20D</sub> Material

**F<sub>20D</sub> Material Specifications**

Property	Unit	Symbol	Value
Initial Permeability (@B < 0.25 mT)		$\mu_i$	2000
Saturation Magnetic Flux Density (@Field Strength)	mT	B <sub>s</sub>	280
Remanent Flux Density	A/m	H	2400
Coercive Force	mT	B <sub>r</sub>	200
Relative Loss Factor (@Frequency)	A/m	H <sub>c</sub>	10
Relative Loss Factor (@Frequency)	$10^{-6}$	$\tan \delta / \mu_i$	15
Temperature Factor of Initial Permeability(20~60°C)	MHz		0.1
Temperature Factor of Initial Permeability(20~60°C)	$10^{-6}/^{\circ}\text{C}$	$\alpha \mu_{ir}$	5
Curie Temperature	$^{\circ}\text{C}$	T <sub>c</sub>	>110
Electrical Resistivity	$\Omega\text{-m}$	$\rho_v$	$10^6$

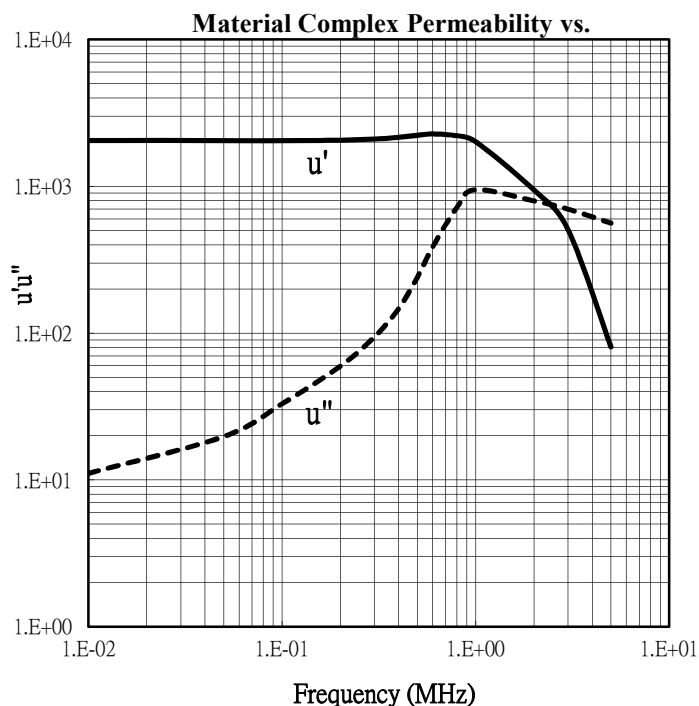

Measured on a 25/5/15mm toroid using the HP 4284A and E4991A

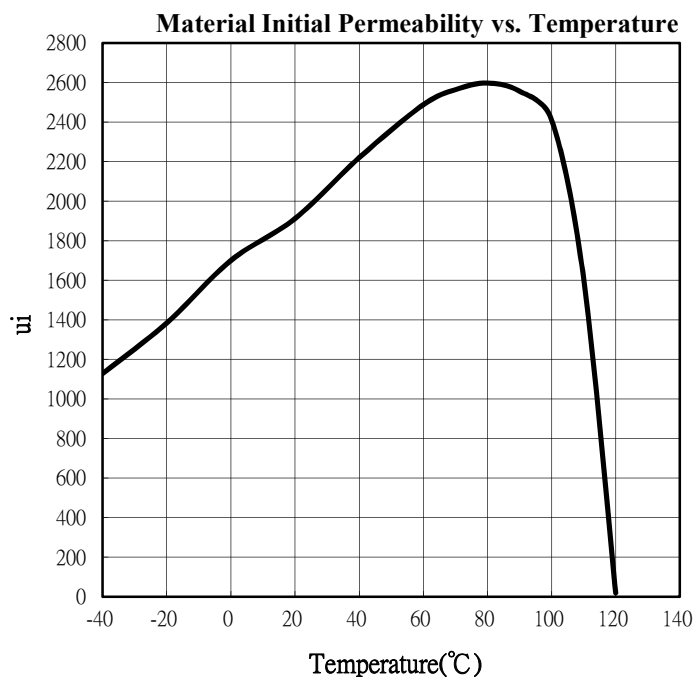

Measured on a 25/5/15mm toroid at 10KHz@B < 0.25 mT using the HP 4284A

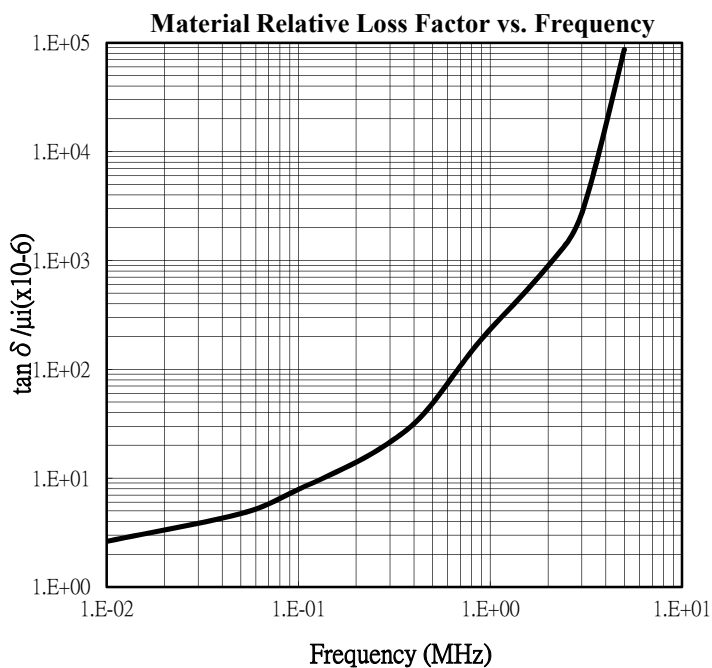

Measured on a 25/5/15mm toroid using the HP 4284A and E4991A

# F<sub>6</sub> Material

**F<sub>6</sub> Material Specifications**

Property	Unit	Symbol	Value
Initial Permeability (@B < 0.25 mT)		$\mu_i$	1500
Saturation Magnetic Flux Density (@Field Strength)	mT	B <sub>s</sub>	250
Remanent Flux Density	A/m	H <sub>c</sub>	20
Coercive Force	mT	Br	120
Relative Loss Factor (@Frequency)	10 <sup>-6</sup> / MHz	$\tan \delta / \mu_i$	20
Temperature Factor of Initial Permeability(RT~70°C)	10 <sup>-6</sup> /°C	$\alpha \mu_{ir}$	3
Curie Temperature	°C	T <sub>c</sub>	>90
Electrical Resistivity	Ω-m	$\rho_v$	10 <sup>6</sup>

**Material Complex Permeability vs.**

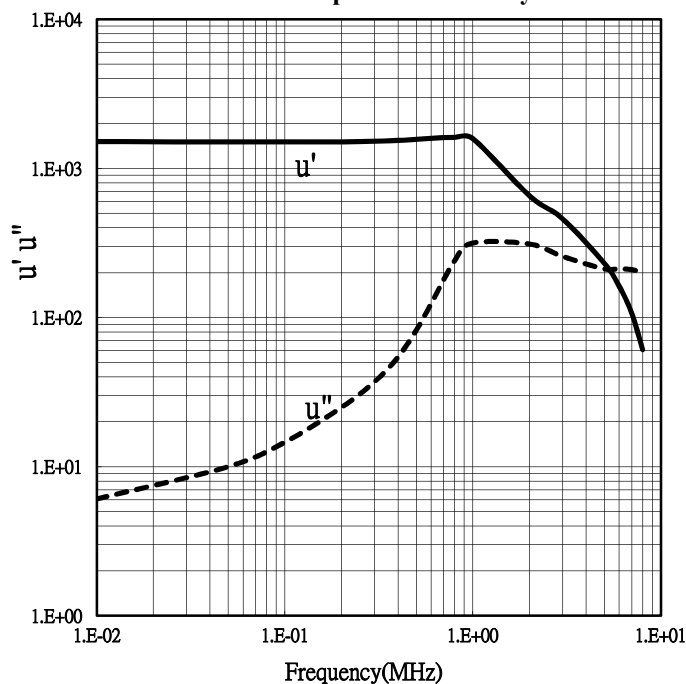

Measured on a 25/5/15mm toroid using the HP 4284A and E4991A

**Material Initial Permeability vs. Temperature**

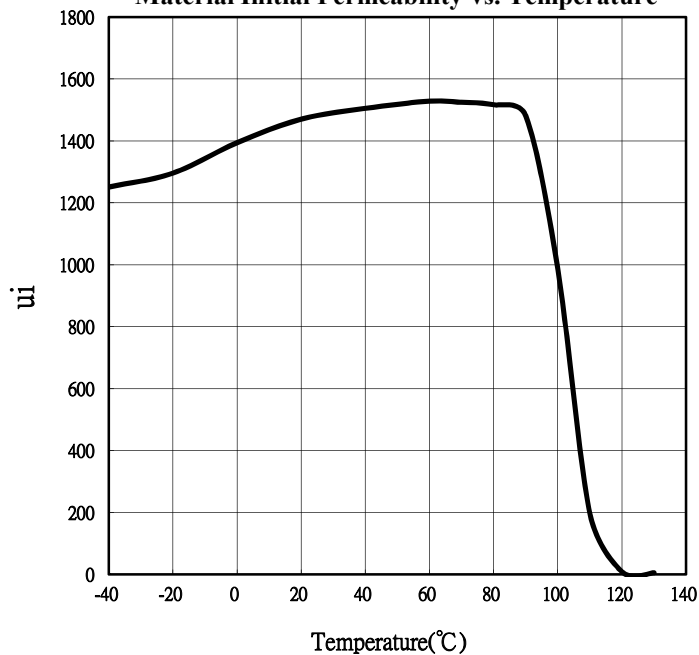

Measured on a 25/5/15mm toroid at 10KHz@B < 0.25 mT using the HP 4284A

**Material Relative Loss Factor vs. Frequency**

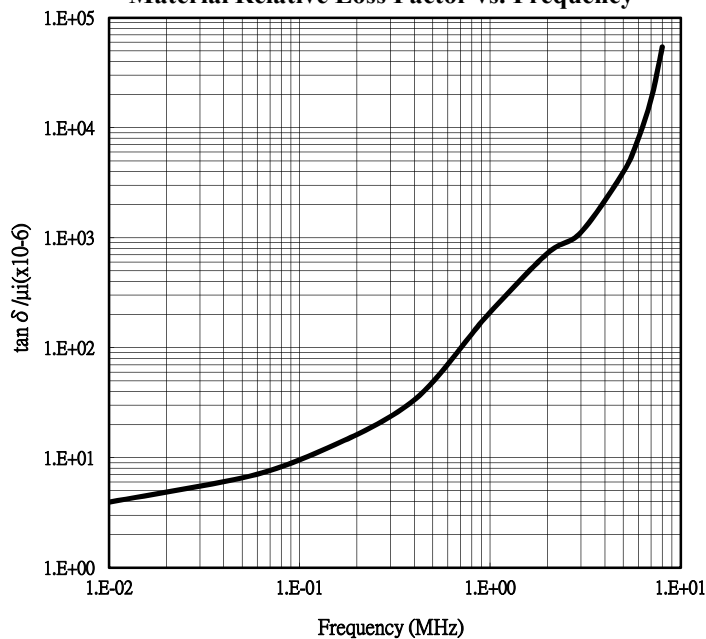

Measured on a 25/5/15mm toroid using the HP 4284A and E4991A

# K<sub>15</sub> Material

**K<sub>15</sub> Material Specifications**

Property	Unit	Symbol	Value
Initial Permeability (@B < 0.25 mT )		$\mu_i$	1500
Saturation Magnetic Flux Density (@Field Strength)	mT	B <sub>s</sub>	230
Remanent Flux Density	A/m	H	3200
Coercive Force	mT	B <sub>r</sub>	200
Relative Loss Factor (@Frequency)	A/m	H <sub>c</sub>	10
Relative Loss Factor (@Frequency)	$10^{-6}$	$\tan \delta / \mu_i$	20
Temperature Factor of Initial Permeability(20~70°C)	MHz		0.1
Temperature Factor of Initial Permeability(20~70°C)	$10^{-6}/^{\circ}\text{C}$	$\alpha \mu_{ir}$	8
Curie Temperature	$^{\circ}\text{C}$	T <sub>c</sub>	>90
Electrical Resistivity	$\Omega\text{-m}$	$\rho_v$	$10^6$

**Material Complex Permeability vs.**

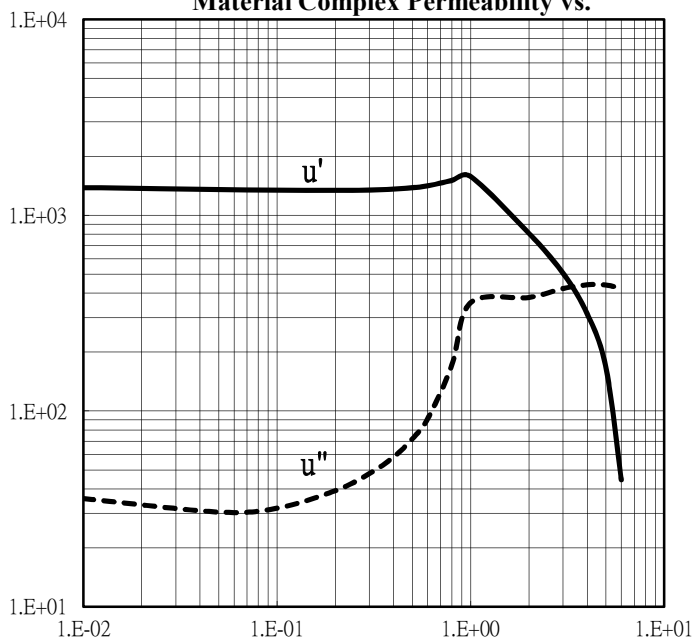

Measured on a 25/5/15mm toroid using the HP 4284A and E4991A

**Material Initial Permeability vs. Temperature**

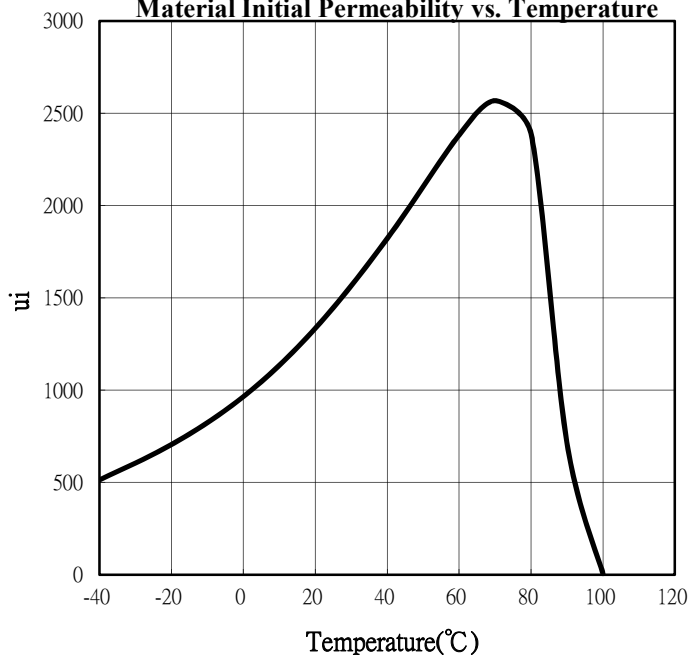

Measured on a 25/5/15mm toroid at 10KHz@B < 0.25 mT using the HP 4284A

**Material Relative Loss Factor vs. Frequency**

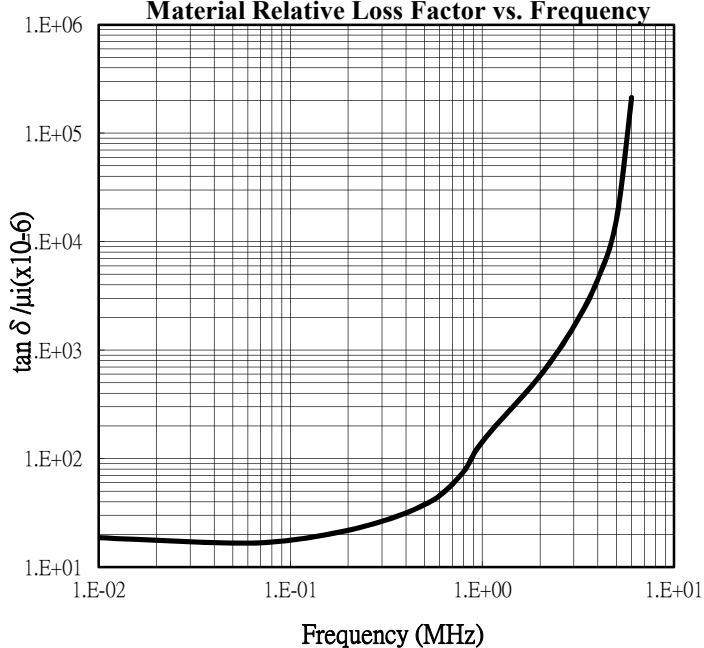

Measured on a 25/5/15mm toroid using the HP 4284A and E4991A

# F<sub>12D</sub> Material

**F<sub>12D</sub> Material Specifications**

Property	Unit	Symbol	Value
Initial Permeability (@B < 0.25 mT)		$\mu_i$	1200
Saturation Magnetic Flux Density (@Field Strength)	mT	B <sub>s</sub>	360
Remanent Flux Density	A/m	H	4000
Coercive Force	mT	B <sub>r</sub>	240
Relative Loss Factor (@Frequency)	A/m	H <sub>c</sub>	10
Temperature Factor of Initial Permeability(20~60°C)	$10^{-6}$	$\tan \delta / \mu_i$	10
	MHz		0.1
Curie Temperature	$10^{-6}/^{\circ}\text{C}$	$\alpha \mu_{ir}$	13
	$^{\circ}\text{C}$	T <sub>c</sub>	>160
Electrical Resistivity	$\Omega\text{-m}$	$\rho_v$	$10^6$

**Material Complex Permeability vs.**

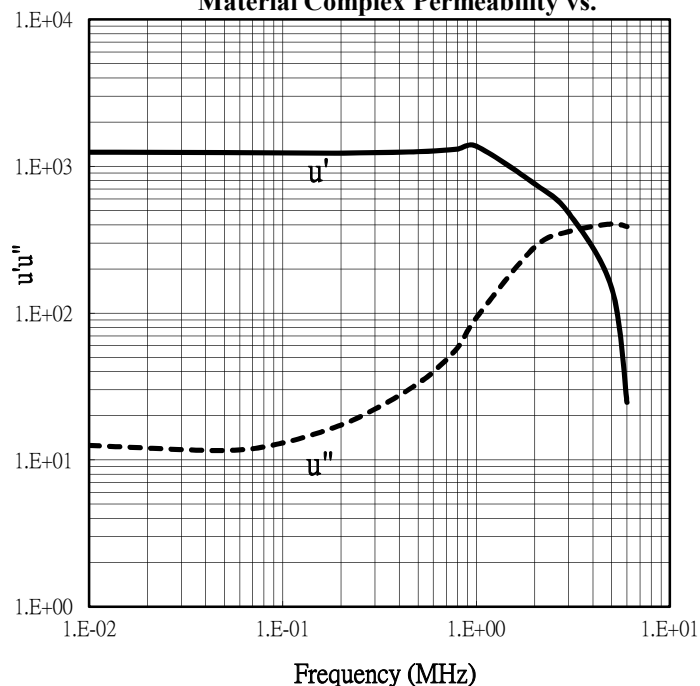

Measured on a 25/5/15mm toroid using the HP 4284A and E4991A

**Material Initial Permeability vs. Temperature**

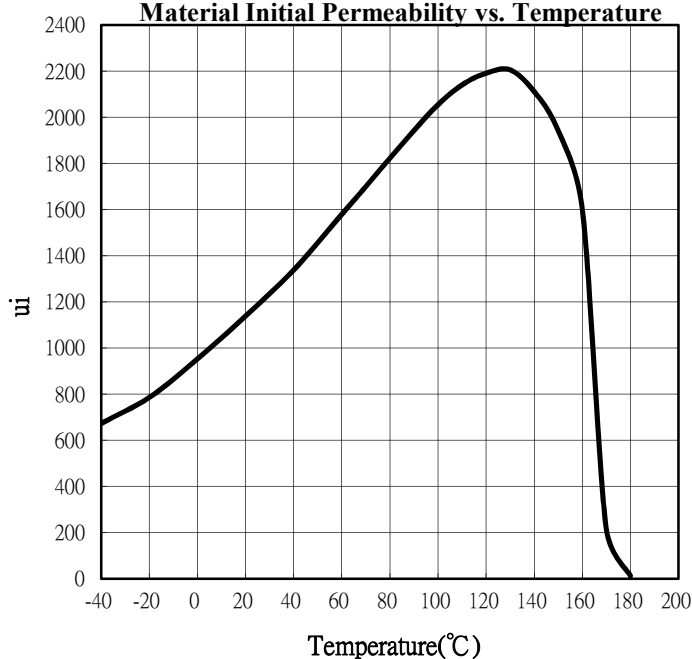

Measured on a 25/5/15mm toroid at 10KHz@B < 0.25 mT using the HP 4284A

**Material Relative Loss Factor vs. Frequency**

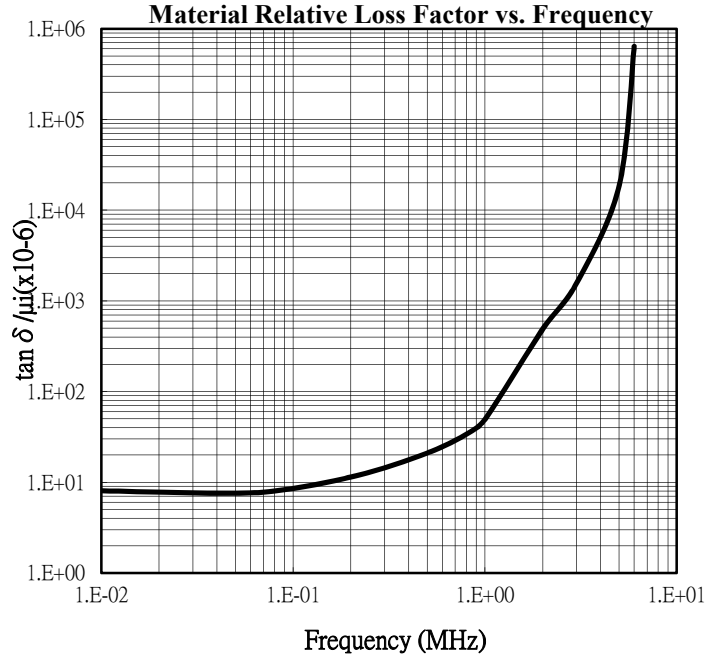

Measured on a 25/5/15mm toroid using the HP 4284A and E4991A

# F<sub>1K</sub> Material

**F<sub>1K</sub> Material Specifications**

Property	Unit	Symbol	Value
Initial Permeability (@B < 0.25 mT)		$\mu_i$	1000
Saturation Magnetic Flux Density (@Field Strength)	mT	B <sub>s</sub>	310
Remanent Flux Density	A/m	H	2800
Coercive Force	mT	B <sub>r</sub>	140
Relative Loss Factor (@Frequency)	A/m	H <sub>c</sub>	32
Relative Loss Factor (@Frequency)	$10^{-6}$	$\tan \delta / \mu_i$	10
Temperature Factor of Initial Permeability(RT~70°C)	MHz		0.1
Temperature Factor of Initial Permeability(RT~70°C)	$10^{-6}/^{\circ}\text{C}$	$\alpha \mu_{ir}$	5
Curie Temperature	$^{\circ}\text{C}$	T <sub>c</sub>	>150
Electrical Resistivity	$\Omega\text{-m}$	$\rho_v$	$10^6$

**Material Complex Permeability vs. Frequency**

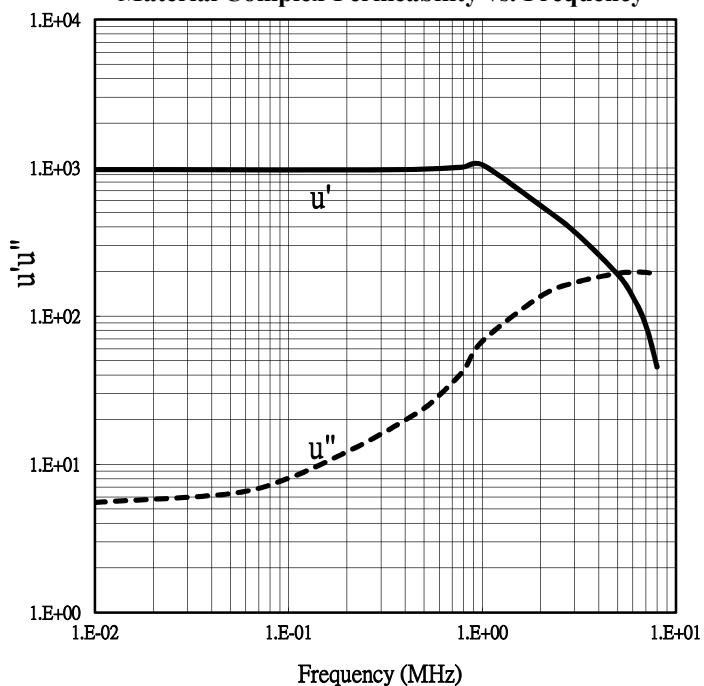

Measured on a 25/5/15mm toroid using the HP 4284A and E4991A

**Material Initial Permeability vs. Temperature**

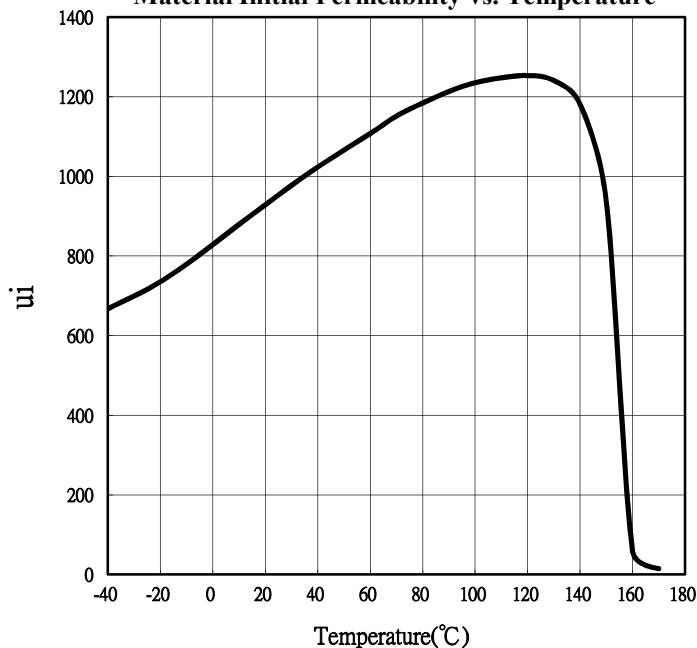

Measured on a 25/5/15mm toroid at 10KHz@B < 0.25 mT using the HP 4284A

**Material Relative Loss Factor vs. Frequency**

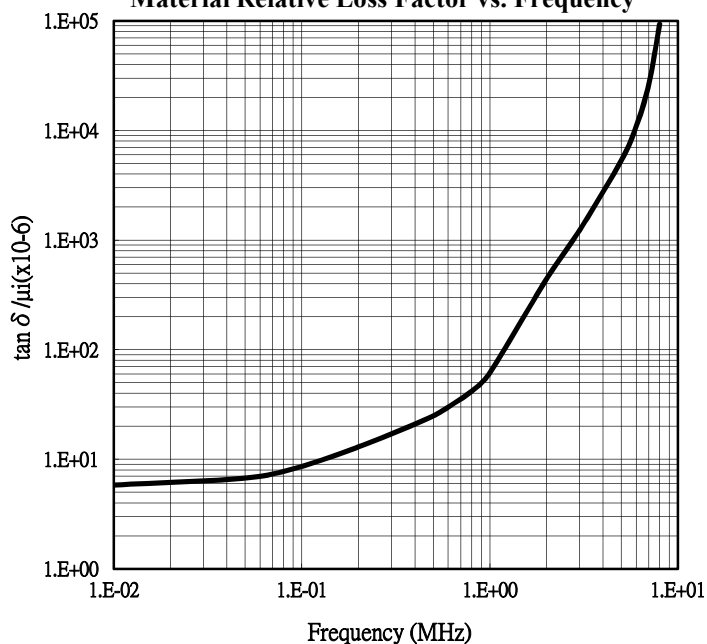

Measured on a 25/5/15mm toroid using the HP 4284A and E4991A

# F<sub>8T</sub> Material

## F<sub>8T</sub> Material Specifications

Property	Unit	Symbol	Value
Initial Permeability (@B < 0.25 mT)		$\mu_i$	800
Saturation Magnetic Flux Density (@Field Strength)	mT	B <sub>s</sub>	320
Remanent Flux Density	A/m	H	4000
Coercive Force	mT	B <sub>r</sub>	200
Relative Loss Factor (@Frequency)	A/m	H <sub>c</sub>	20
Relative Loss Factor (@Frequency)	$10^{-6}$ MHz	$\tan \delta / \mu_i$	20 0.1
Temperature Factor of Initial Permeability(20~70°C)	$10^{-6}/^{\circ}\text{C}$	$\alpha \mu_{ir}$	-1~1
Curie Temperature	$^{\circ}\text{C}$	T <sub>c</sub>	>130
Electrical Resistivity	$\Omega\text{-m}$	$\rho_v$	$10^6$

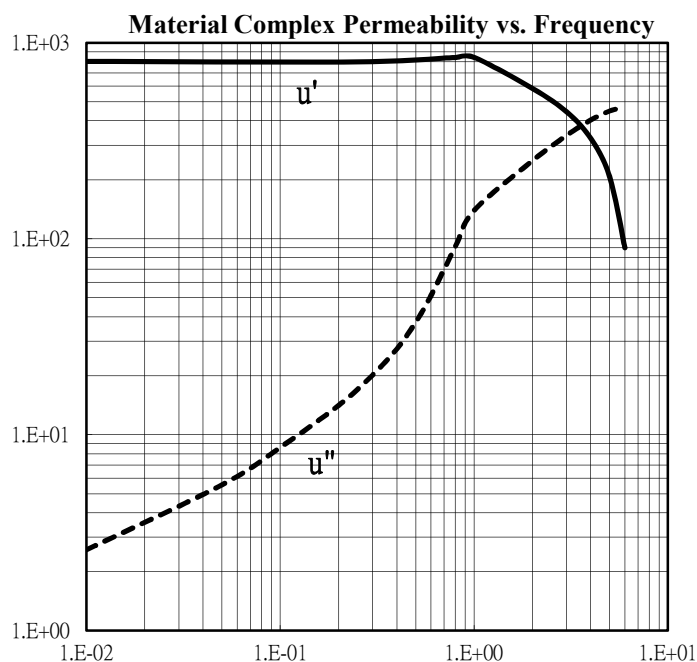

Measured on a 25/5/15mm toroid using the HP 4284A and E4991A

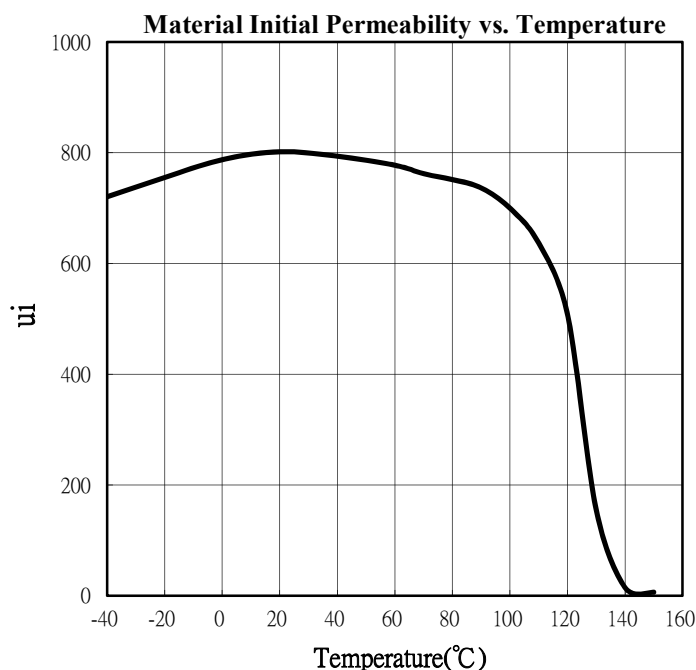

Measured on a 25/5/15mm toroid at 10KHz@B < 0.25 mT using the HP 4284A

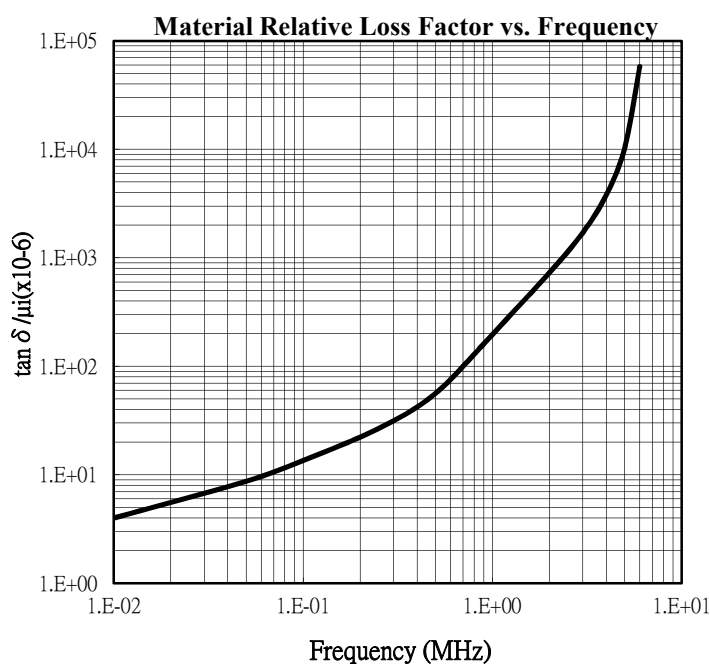

Measured on a 25/5/15mm toroid using the HP 4284A and E4991A

# T<sub>4A</sub> Material

**T<sub>4A</sub> Material Specifications**

Property	Unit	Symbol	Value
Initial Permeability (@B < 0.25 mT)		$\mu_i$	800
Saturation Magnetic Flux Density (@Field Strength)	mT	B <sub>s</sub>	310
Remanent Flux Density	A/m	H	2400
Coercive Force	mT	B <sub>r</sub>	200
Relative Loss Factor (@Frequency)	A/m	H <sub>c</sub>	52
Relative Loss Factor (@Frequency)	$10^{-6}$	$\tan \delta / \mu_i$	20
Temperature Factor of Initial Permeability(RT~70°C)	MHz		0.1
Temperature Factor of Initial Permeability(RT~70°C)	$10^{-6}/^{\circ}\text{C}$	$\alpha \mu_{ir}$	20
Curie Temperature	$^{\circ}\text{C}$	T <sub>c</sub>	>160
Electrical Resistivity	$\Omega\text{-m}$	$\rho_v$	$10^6$

**Material Complex Permeability vs. Frequency**

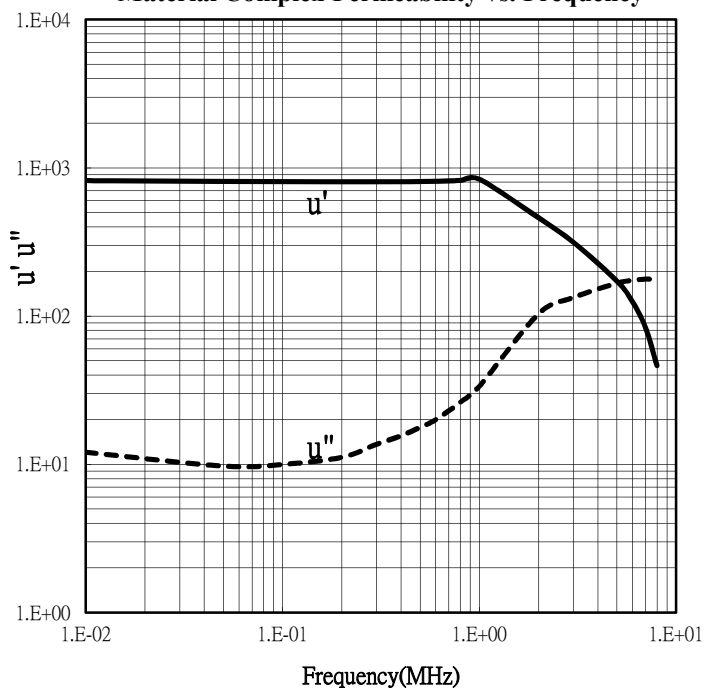

Measured on a 25/5/15mm toroid using the HP 4284A and E4991A

**Material Initial Permeability vs. Temperature**

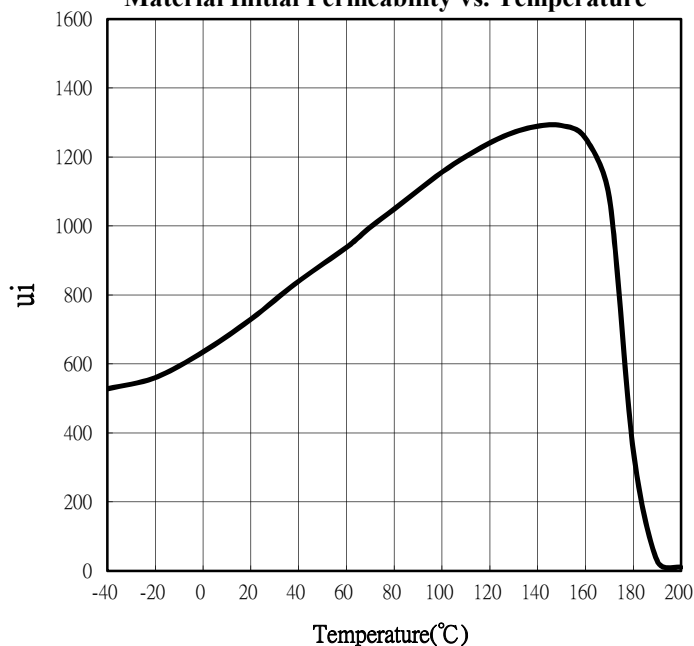

Measured on a 25/5/15mm toroid at 10KHz@B < 0.25 mT using the HP 4284A

**Material Relative Loss Factor vs. Frequency**

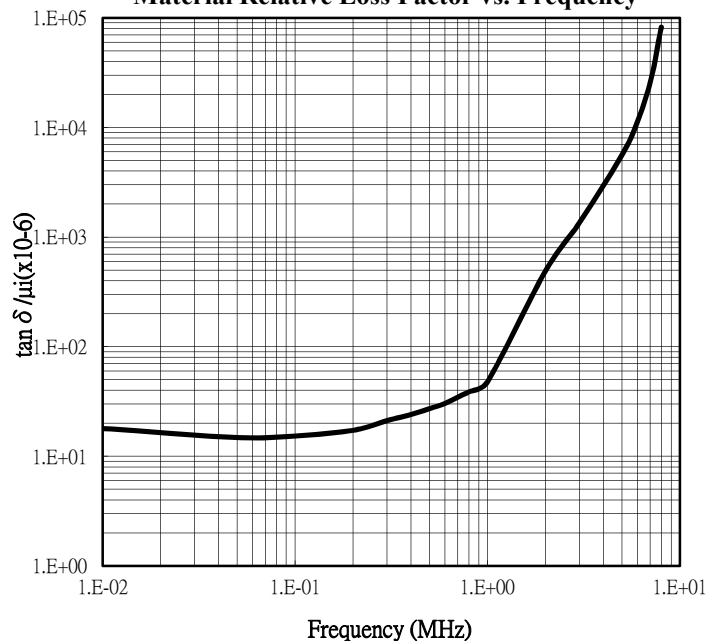

Measured on a 25/5/15mm toroid using the HP 4284A and E4991A

# T<sub>4A</sub> Material

**Material Amplitude Permeability vs. Flux Density**

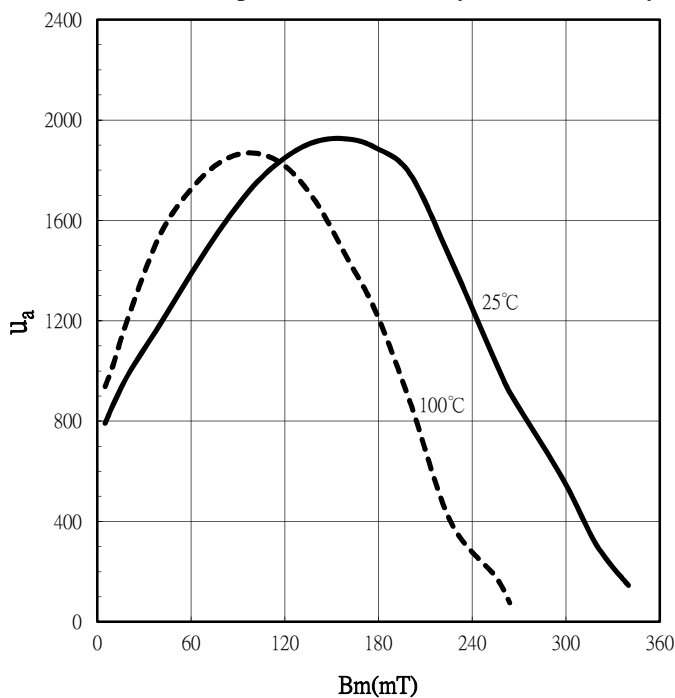

Measured on a 25/5/15mm toroid at 10KHz

**Material Power Loss Density vs. Flux Density**

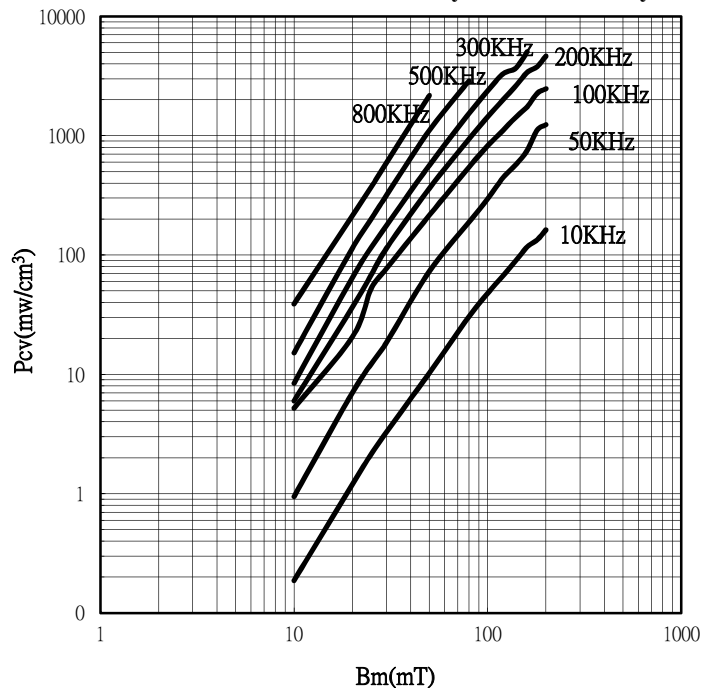

Measured on a 25/5/15mm toroid using the SY 8232 B-H ANALYZER at 25°C

**Material Power Loss Density vs. Temp.**

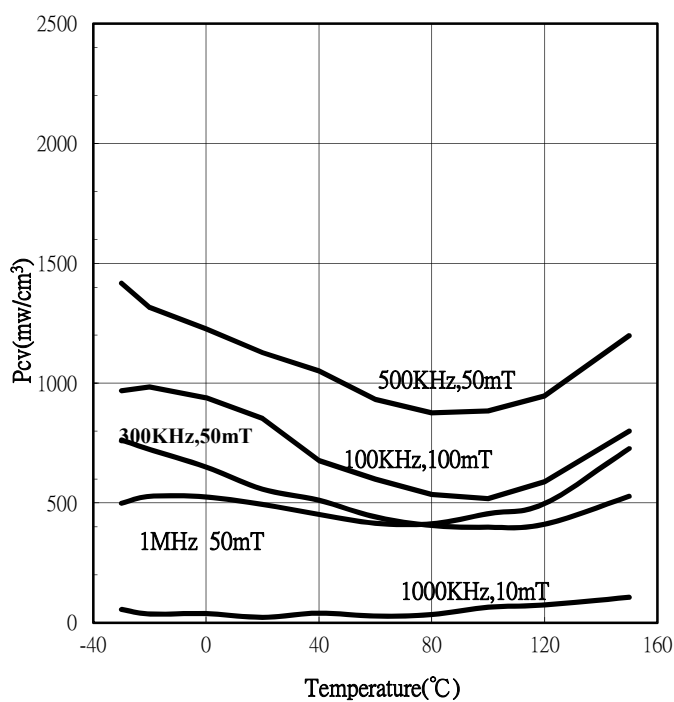

Measured on a 25/5/15mm toroid using the SY 8232 B-H ANALYZER

**Material Saturation Magnetic Flux Density vs. Temp.**

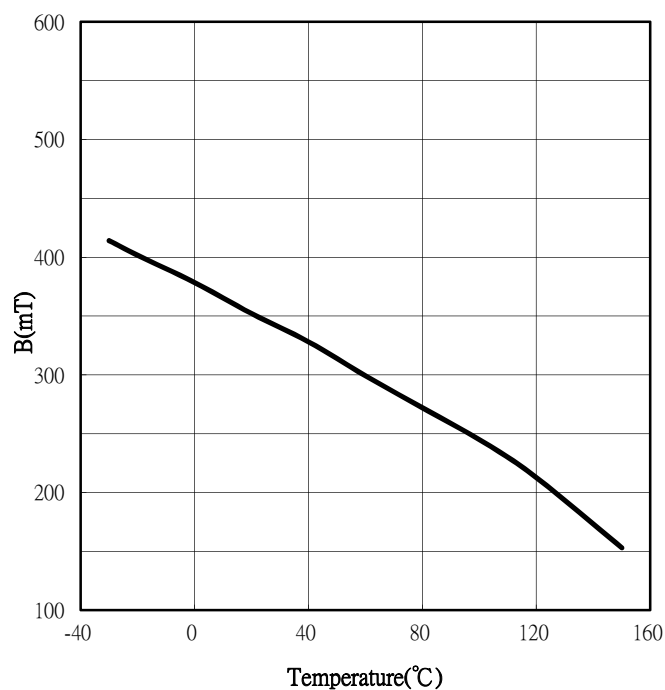

Measured on a 25/5/15mm toroid at 1KHz and Hm=2400A/m

# K<sub>3</sub> Material

**K<sub>3</sub> Material Specifications**

Property	Unit	Symbol	Value
Initial Permeability (@B < 0.25 mT)		$\mu_i$	800
Saturation Magnetic Flux Density (@Field Strength)	mT	B <sub>s</sub>	250
Remanent Flux Density	A/m	H	2400
Coercive Force	mT	B <sub>r</sub>	140
Relative Loss Factor (@Frequency)	A/m	H <sub>c</sub>	28
Relative Loss Factor (@Frequency)	$10^{-6}$	$\tan \delta / \mu_i$	30
Temperature Factor of Initial Permeability(RT~70°C)	MHz		0.1
Temperature Factor of Initial Permeability(RT~70°C)	$10^{-6}/^{\circ}\text{C}$	$\alpha \mu_{ir}$	15
Curie Temperature	$^{\circ}\text{C}$	T <sub>c</sub>	>110
Electrical Resistivity	$\Omega\text{-m}$	$\rho_v$	$10^6$

**Material Complex Permeability vs. Frequency**

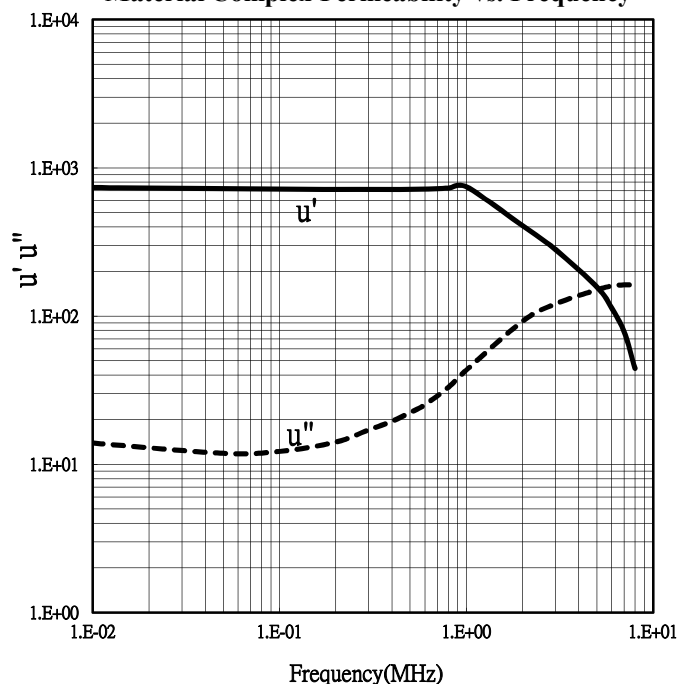

Measured on a 25/5/15mm toroid using the HP 4284A and E4991A

**Material Initial Permeability vs. Temperature**

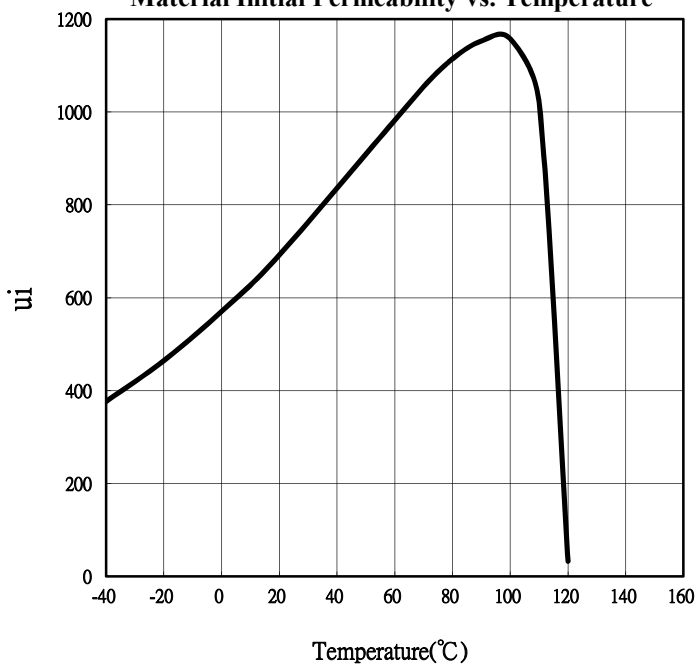

Measured on a 25/5/15mm toroid at 10KHz@B < 0.25 mT using the HP 4284A

**Material Relative Loss Factor vs. Frequency**

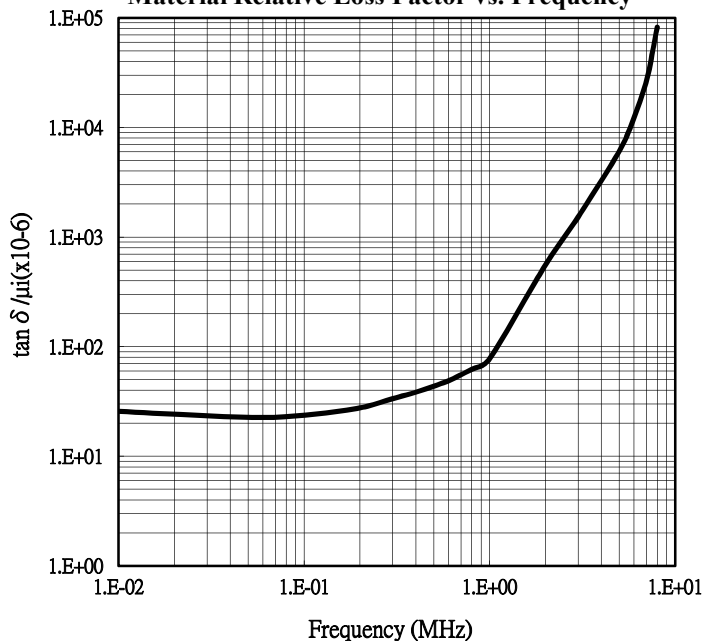

Measured on a 25/5/15mm toroid using the HP 4284A and E4991A

# K<sub>1</sub> Material

**K<sub>1</sub> Material Specifications**

Property	Unit	Symbol	Value
Initial Permeability (@B < 0.25 mT)		$\mu_i$	650
Saturation Magnetic Flux Density (@Field Strength)	mT	B <sub>s</sub>	260
Remanent Flux Density	A/m	H	1600
Coercive Force	mT	B <sub>r</sub>	180
Relative Loss Factor (@Frequency)	A/m	H <sub>c</sub>	28
Relative Loss Factor (@Frequency)	$10^{-6}$ MHz	$\tan \delta / \mu_i$	35 0.1
Temperature Factor of Initial Permeability(RT~70°C)	$10^{-6}/^{\circ}\text{C}$	$\alpha \mu_{ir}$	40
Curie Temperature	$^{\circ}\text{C}$	T <sub>c</sub>	>120
Electrical Resistivity	$\Omega\text{-m}$	$\rho_v$	$10^6$

**Material Complex Permeability vs. Frequency**

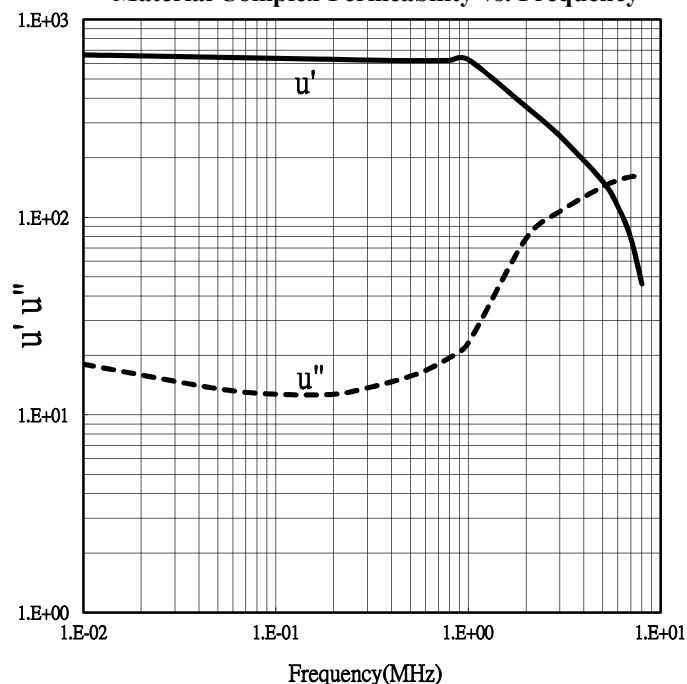

Measured on a 25/5/15mm toroid using the HP 4284A and E4991A

**Material Initial Permeability vs. Temperature**

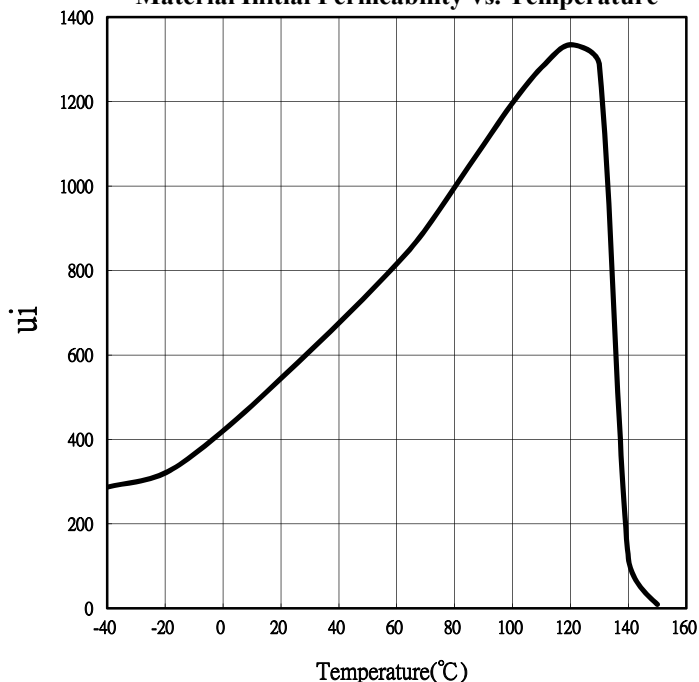

Measured on a 25/5/15mm toroid at 10KHz@B < 0.25 mT using the HP 4284A

**Material Relative Loss Factor vs. Frequency**

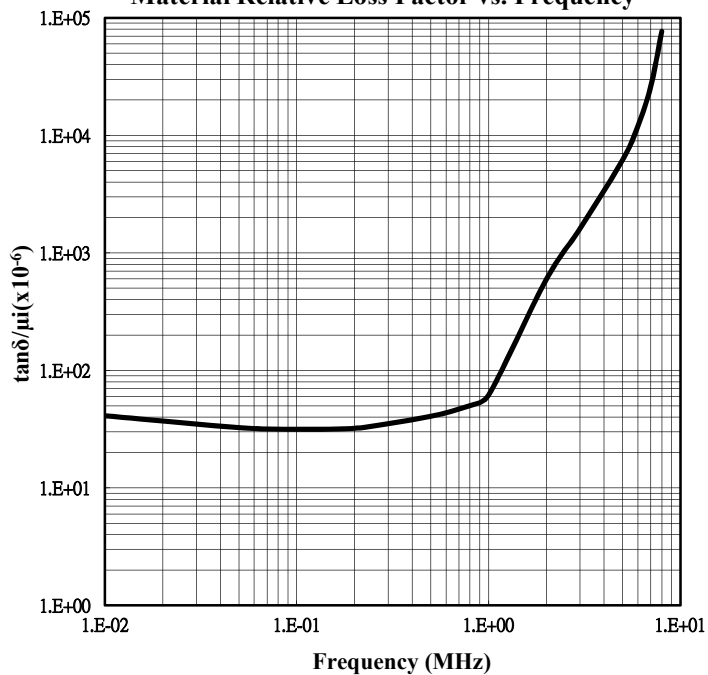

Measured on a 25/5/15mm toroid using the HP 4284A and E4991A

# F<sub>5H</sub> Material

**F<sub>5H</sub> Material Specifications**

Property	Unit	Symbol	Value
Initial Permeability (@B < 0.25 mT)		$\mu_i$	500
Saturation Magnetic Flux Density (@Field Strength)	mT	B <sub>s</sub>	380
	A/m	H	4000
Remanent Flux Density	mT	B <sub>r</sub>	200
Coercive Force	A/m	H <sub>c</sub>	48
Relative Loss Factor (@Frequency)	$10^{-6}$ MHz	$\tan \delta / \mu_i$	15 0.1
Temperature Factor of Initial Permeability(RT~70°C)	$10^{-6}/^{\circ}\text{C}$	$\alpha \mu_{ir}$	15
Curie Temperature	$^{\circ}\text{C}$	T <sub>c</sub>	>200
Electrical Resistivity	$\Omega\text{-m}$	$\rho_v$	$10^6$

**Material Complex Permeability vs. Frequency**

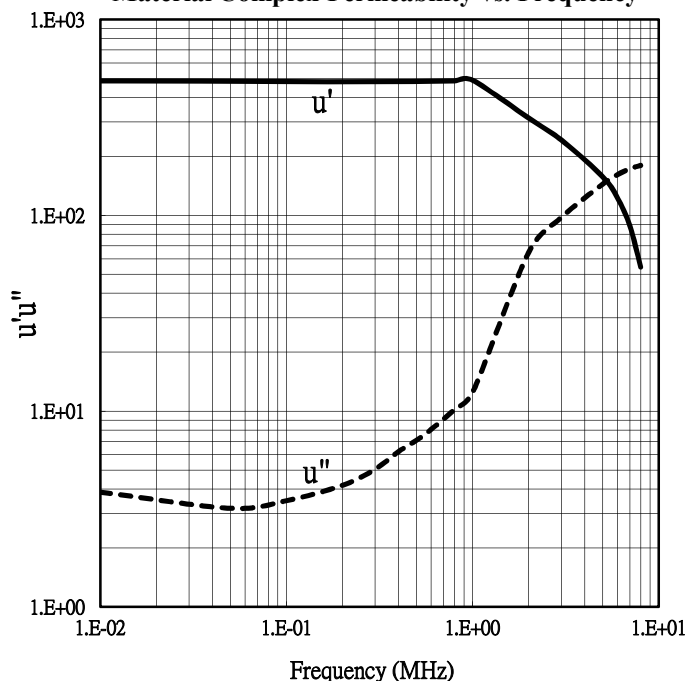

Measured on a 25/5/15mm toroid using the HP 4284A and E4991A

**Material Initial Permeability vs. Temperature**

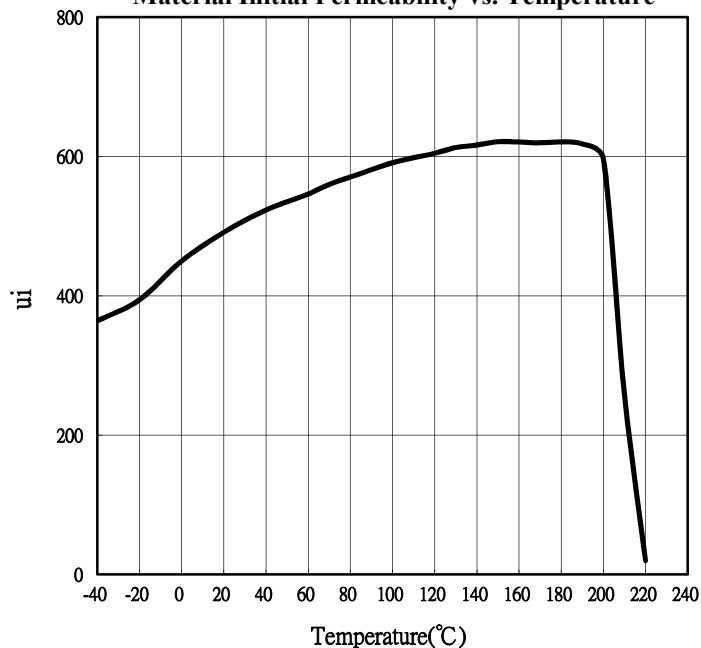

Measured on a 25/5/15mm toroid at 10KHz@B < 0.25 mT using the HP 4284A

**Material Relative Loss Factor vs. Frequency**

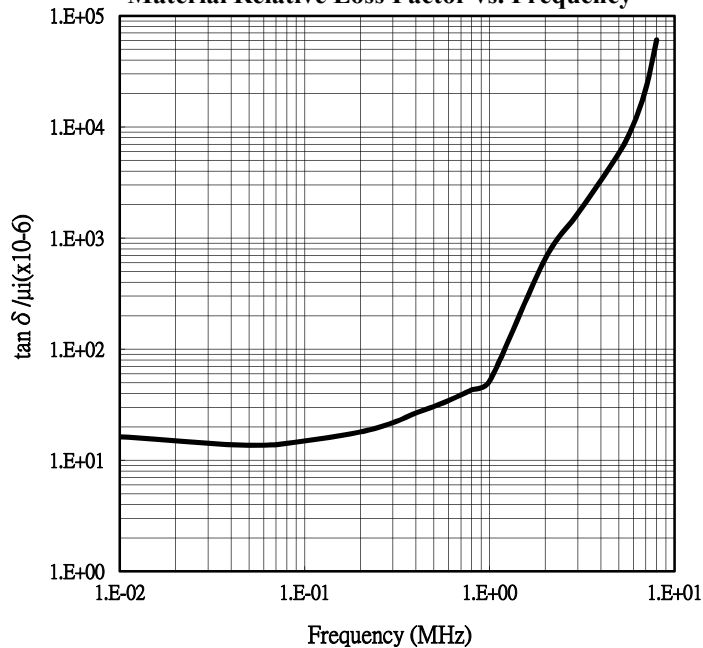

Measured on a 25/5/15mm toroid using the HP 4284A and E4991A

# F<sub>5H</sub> Material

**Material Amplitude Permeability vs. Flux Density**

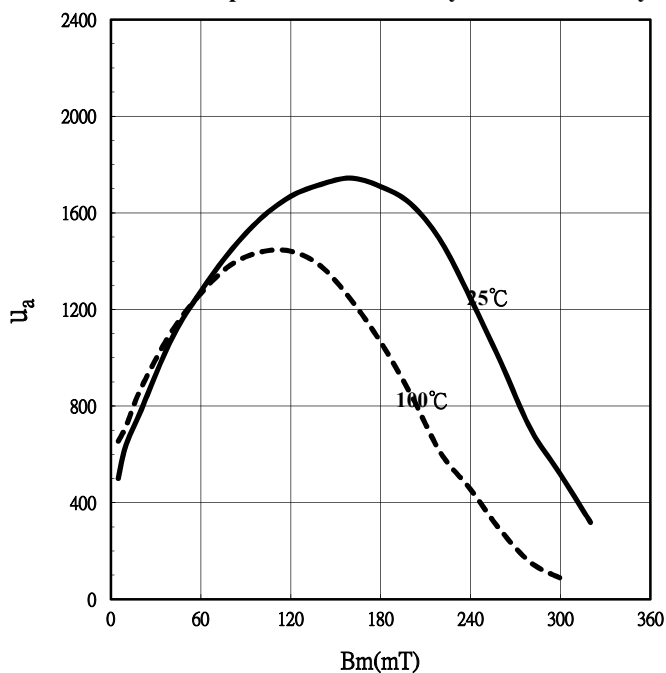

Measured on a 25/5/15mm toroid at 10KHz

**Material Power Loss Density vs. Flux Density**

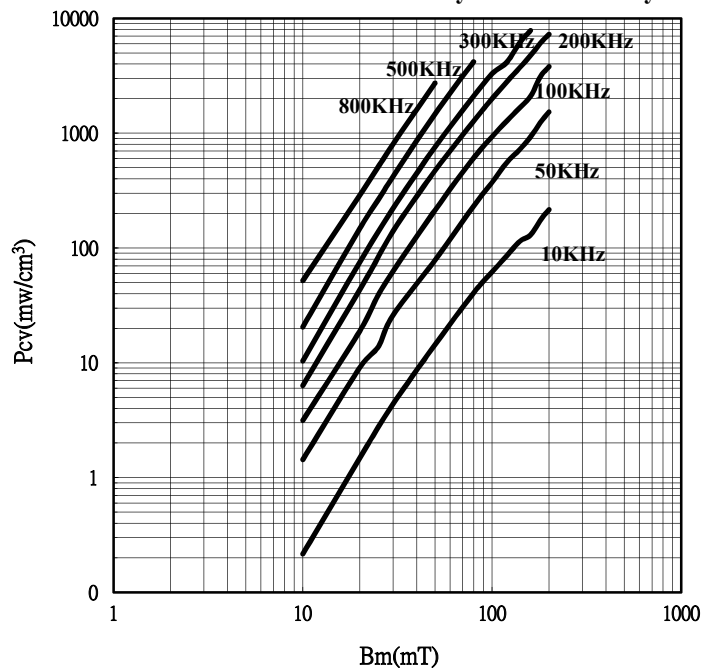

Measured on a 25/5/15mm toroid using the SY 8232 B-H ANALYZER at 25°C

**Material Power Loss Density vs. Temp.**

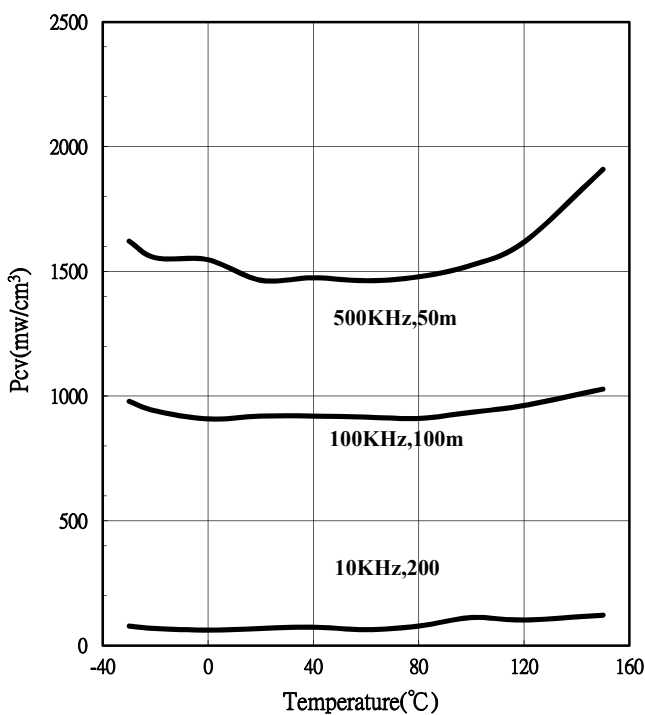

Measured on a 25/5/15mm toroid using the SY 8232 B-H ANALYZER

**Material Saturation Magnetic Flux Density vs. Temp.**

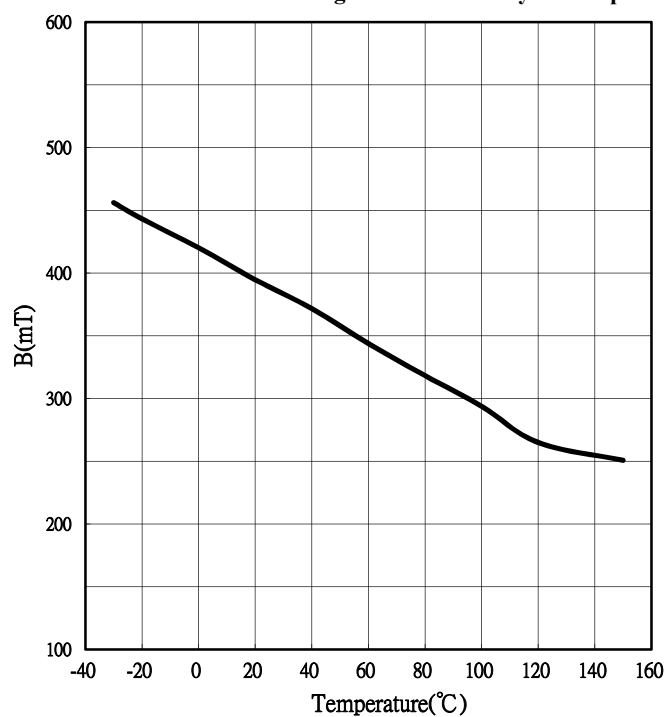

Measured on a 25/5/15mm toroid at 1KHz and  $H_m=4000A/m$

# F<sub>5T</sub> Material

## F<sub>5T</sub> Material Specifications

Property	Unit	Symbol	Value
Initial Permeability (@B < 0.25 mT)		$\mu_i$	500
Saturation Magnetic Flux Density (@Field Strength)	mT	B <sub>s</sub>	360
Remanent Flux Density	A/m	H	4000
Coercive Force	mT	B <sub>r</sub>	240
Relative Loss Factor (@Frequency)	A/m	H <sub>c</sub>	50
Relative Loss Factor (@Frequency)	$10^{-6}$	$\tan \delta / \mu_i$	45
Temperature Factor of Initial Permeability (RT~70°C)	MHz		0.1
Temperature Factor of Initial Permeability (RT~70°C)	$10^{-6}/^{\circ}\text{C}$	$\alpha \mu_{ir}$	0~1
Curie Temperature	$^{\circ}\text{C}$	T <sub>c</sub>	>200
Electrical Resistivity	$\Omega\text{-m}$	$\rho_v$	$10^6$

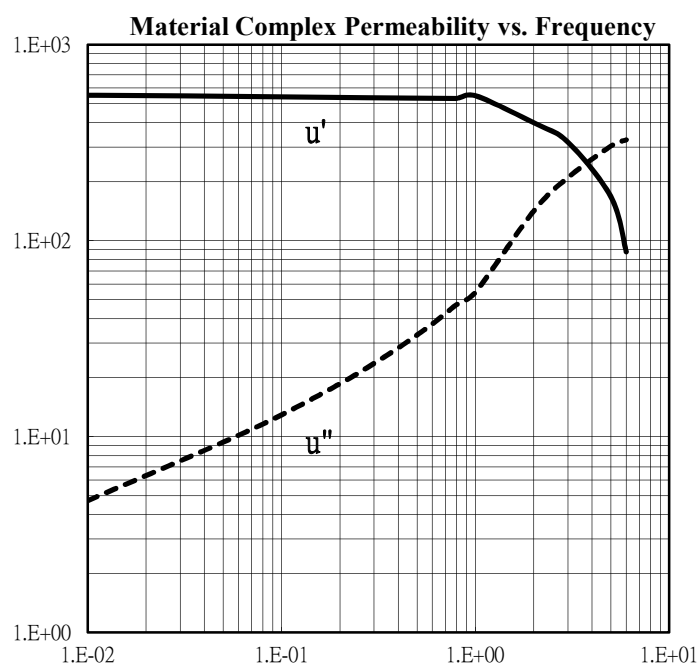

Measured on a 25/5/15mm toroid using the HP 4284A and E4991A

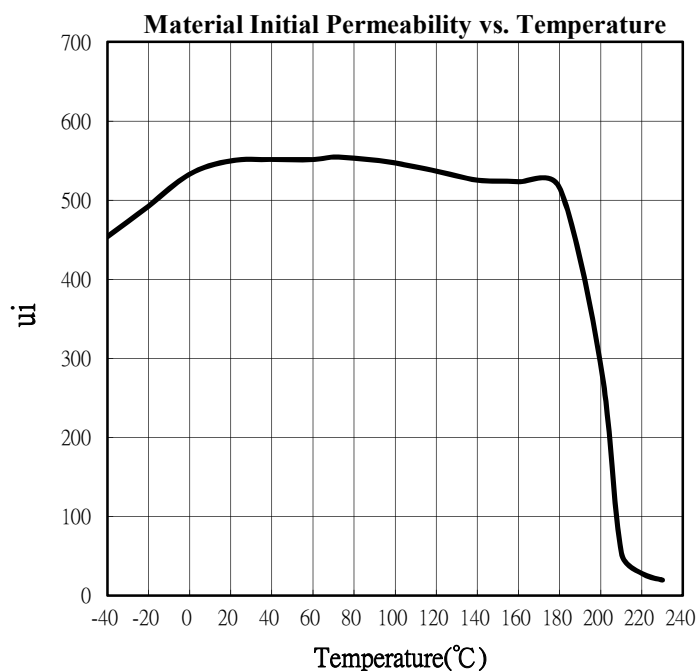

Measured on a 25/5/15mm toroid at 10KHz @B < 0.25 mT using the HP 4284A

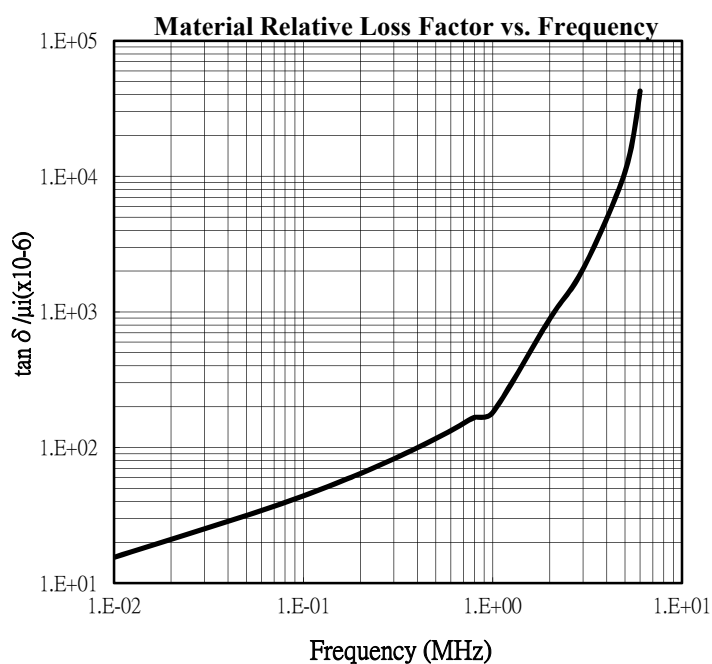

Measured on a 25/5/15mm toroid using the HP 4284A and E4991A

# F<sub>4</sub> Material

**F<sub>4</sub> Material Specifications**

Property	Unit	Symbol	Value
Initial Permeability (@B < 0.25 mT)		$\mu_i$	400
Saturation Magnetic Flux Density (@Field Strength)	mT	B <sub>s</sub>	440
Remanent Flux Density	A/m	H	4400
Coercive Force	mT	B <sub>r</sub>	330
Relative Loss Factor (@Frequency)	A/m	H <sub>c</sub>	32
Relative Loss Factor (@Frequency)	$10^{-6}$	$\tan \delta / \mu_i$	30
Temperature Factor of Initial Permeability(RT~70°C)	MHz		0.3
Temperature Factor of Initial Permeability(RT~70°C)	$10^{-6}/^{\circ}\text{C}$	$\alpha \mu_{ir}$	30
Curie Temperature	$^{\circ}\text{C}$	T <sub>c</sub>	>240
Electrical Resistivity	$\Omega\text{-m}$	$\rho_v$	$10^6$

**Material Complex Permeability vs. Frequency**

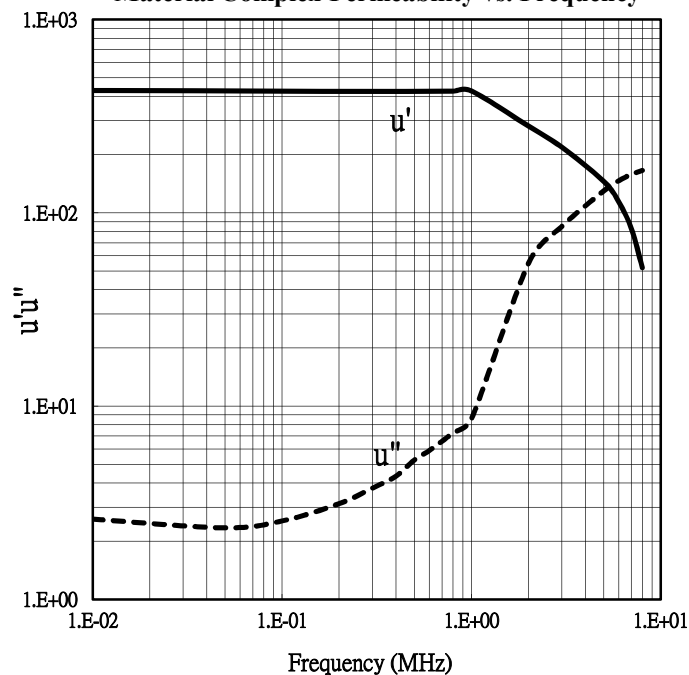

Measured on a 25/5/15mm toroid using the HP 4284A and E4991A

**Material Initial Permeability vs. Temperature**

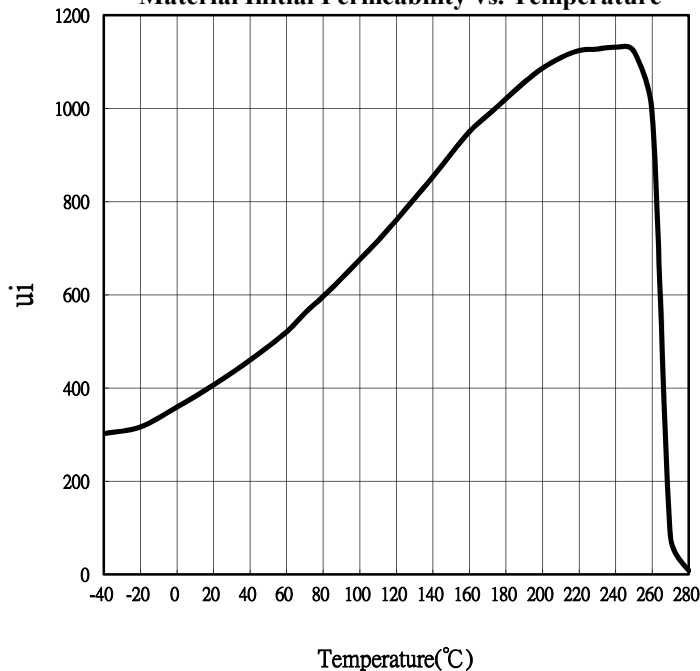

Measured on a 25/5/15mm toroid at 10KHz@B < 0.25 mT using the HP 4284A

**Material Relative Loss Factor vs. Frequency**

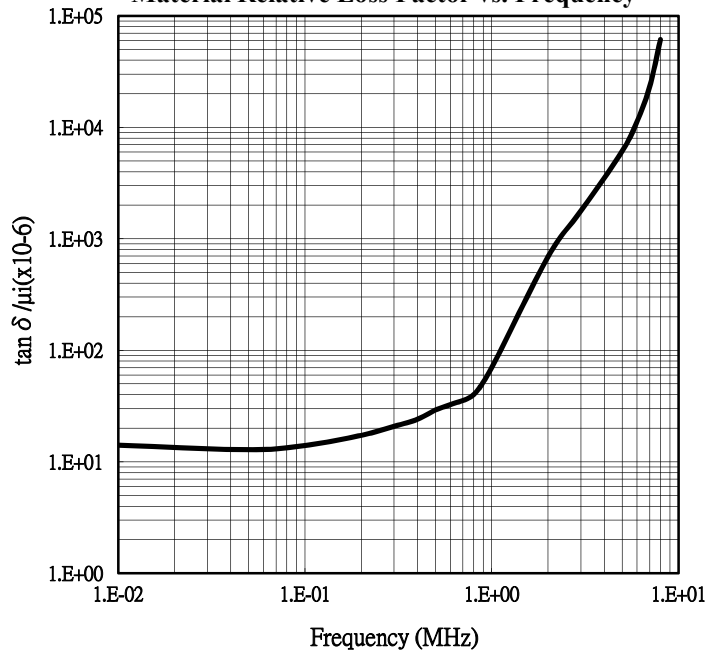

Measured on a 25/5/15mm toroid using the HP 4284A and E4991A

# F<sub>4</sub> Material

**Material Amplitude Permeability vs. Flux Density**

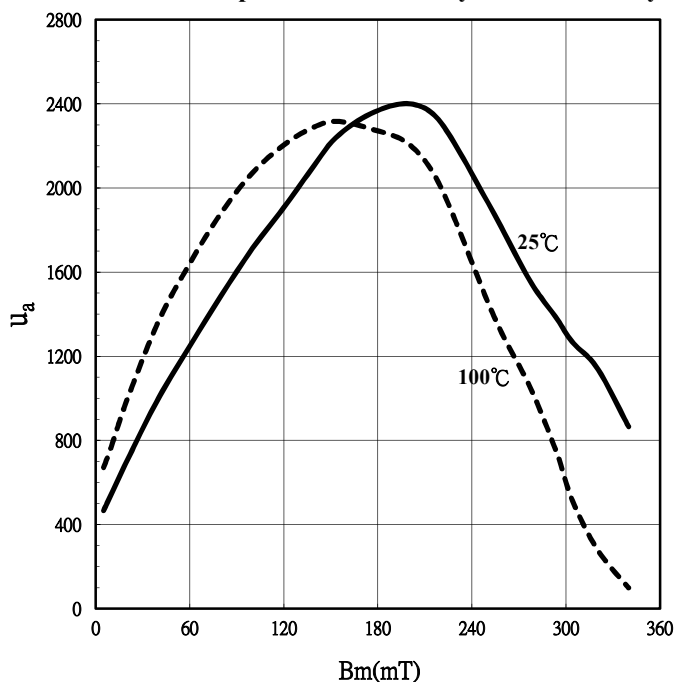

Measured on a 25/5/15mm toroid at 10KHz

**Material Power Loss Density vs. Flux Density**

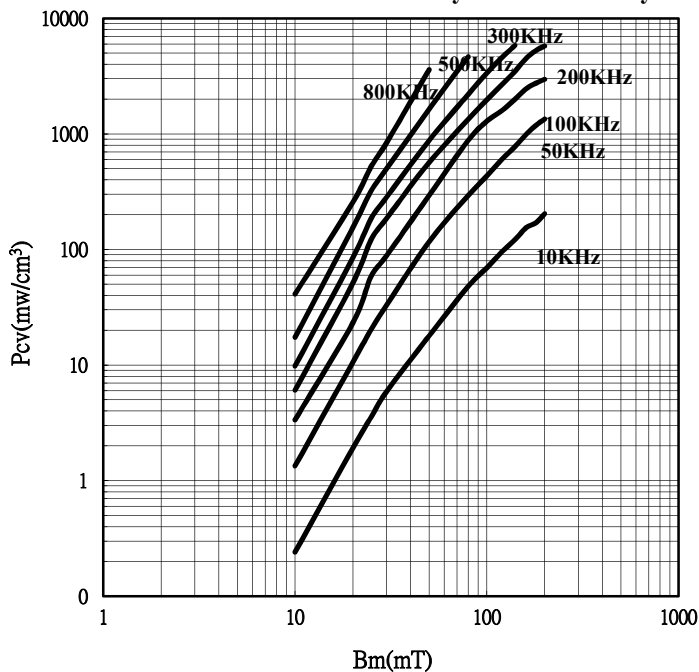

Measured on a 25/5/15mm toroid using the SY 8232 B-H ANALYZER at 25°C

**Material Power Loss Density vs. Temp.**

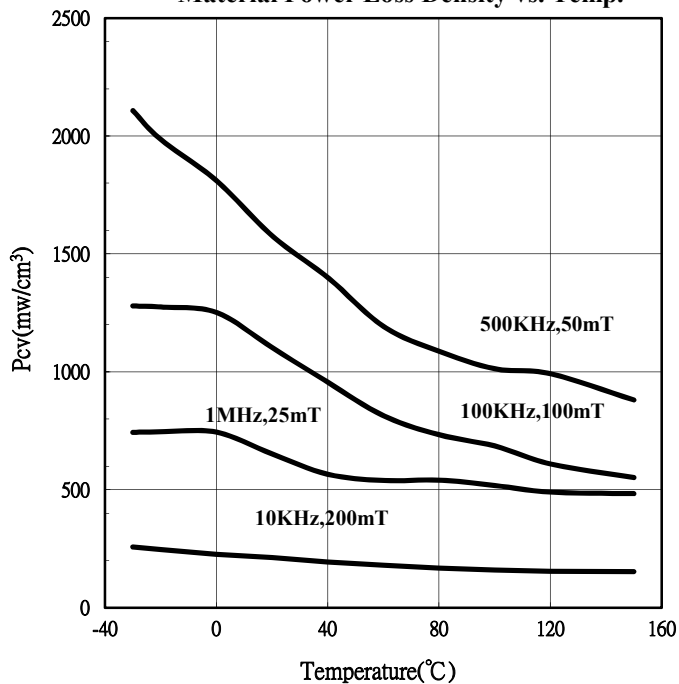

Measured on a 25/5/15mm toroid using the SY 8232 B-H ANALYZER

**Material Saturation Magnetic Flux Density vs. Temp.**

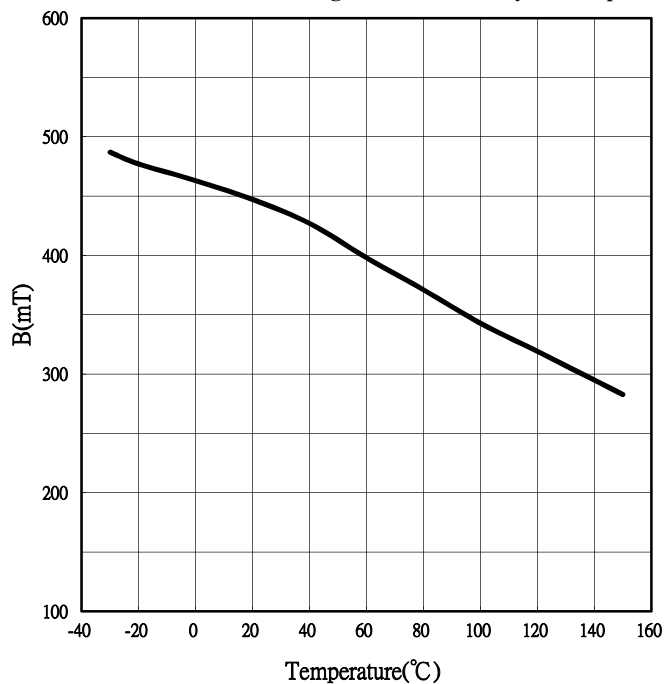

Measured on a 25/5/15mm toroid at 1KHz and Hm=4400A/m

# F<sub>4T</sub> Material

## F<sub>4T</sub> Material Specifications

Property	Unit	Symbol	Value
Initial Permeability (@B < 0.25 mT)		$\mu_i$	400
Saturation Magnetic Flux Density (@Field Strength)	mT	B <sub>s</sub>	290
Remanent Flux Density	A/m	H	1600
Coercive Force	mT	B <sub>r</sub>	140
Relative Loss Factor (@Frequency)	A/m	H <sub>c</sub>	50
Relative Loss Factor (@Frequency)	$10^{-6}$ MHz	$\tan \delta / \mu_i$	30
Temperature Factor of Initial Permeability(20~70°C)	$10^{-6}/^{\circ}\text{C}$	$\alpha \mu_{ir}$	0~1
Curie Temperature	$^{\circ}\text{C}$	T <sub>c</sub>	>160
Electrical Resistivity	$\Omega\text{-m}$	$\rho_v$	$10^6$

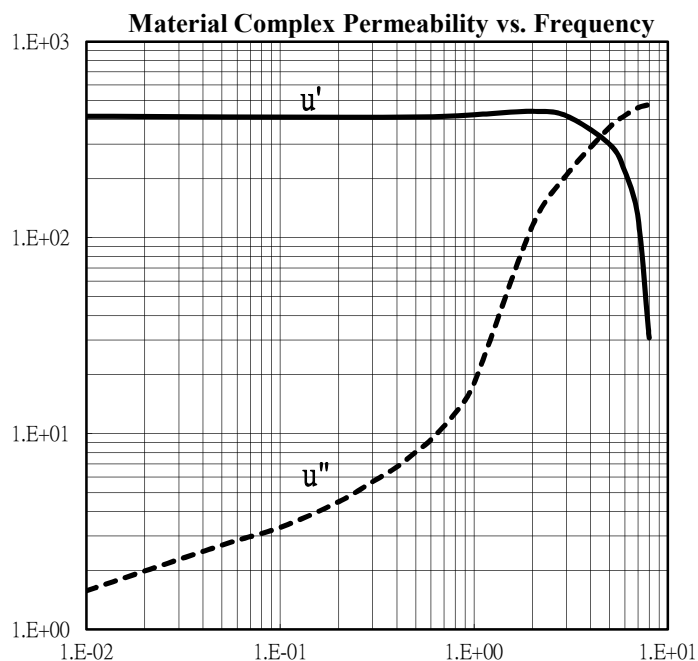

Measured on a 25/5/15mm toroid using the HP 4284A and E4991A

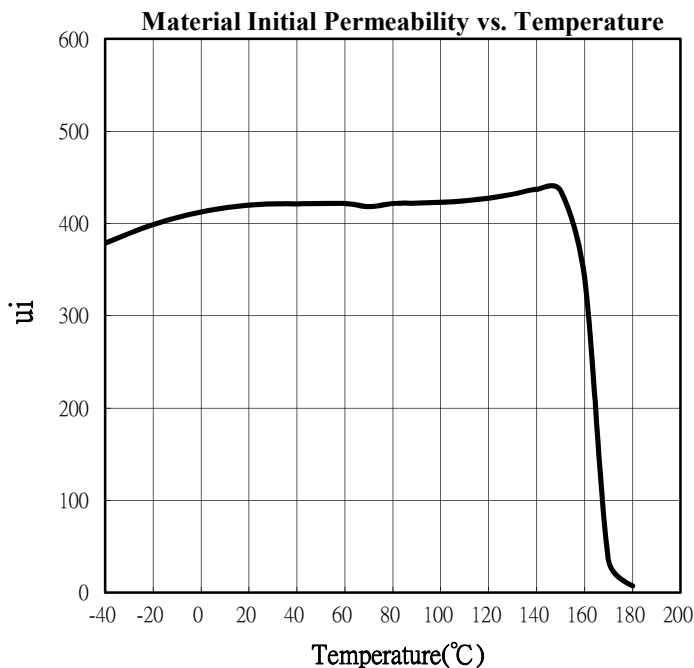

Measured on a 25/5/15mm toroid at 10KHz@B < 0.25 mT using the HP 4284A

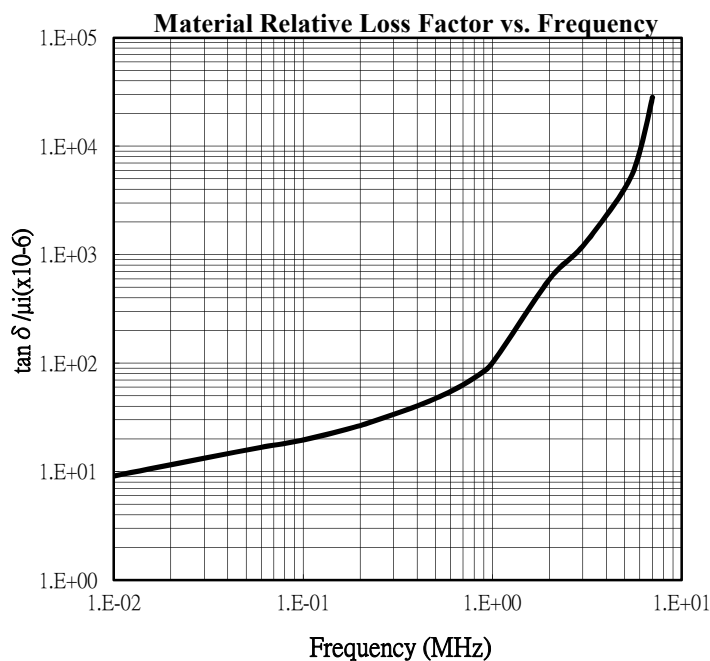

Measured on a 25/5/15mm toroid using the HP 4284A and E4991A

# J<sub>02</sub> Material

**J<sub>02</sub> Material Specifications**

Property	Unit	Symbol	Value
Initial Permeability (@B < 0.25 mT)		$\mu_i$	250
Saturation Magnetic Flux Density (@Field Strength)	mT	Bs	460
Remanent Flux Density	A/m	Br	310
Coercive Force	mT	Hc	60
Relative Loss Factor (@Frequency)	$10^{-6}$ MHz	$\tan \delta / \mu_i$	30 0.1
Temperature Factor of Initial Permeability(RT~70°C)	$10^{-6}/^{\circ}\text{C}$	$\alpha \mu_{ir}$	20
Curie Temperature	$^{\circ}\text{C}$	Tc	>300
Electrical Resistivity	$\Omega\text{-m}$	$\rho_v$	$10^6$

**Material Complex Permeability vs. Frequency**

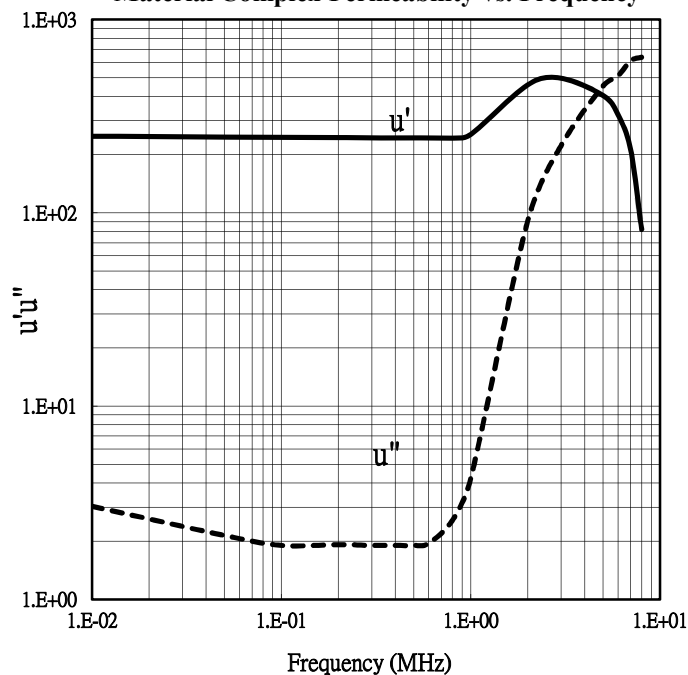

Measured on a 25/5/15mm toroid using the HP 4284A and E4991A

**Material Initial Permeability vs. Temperature**

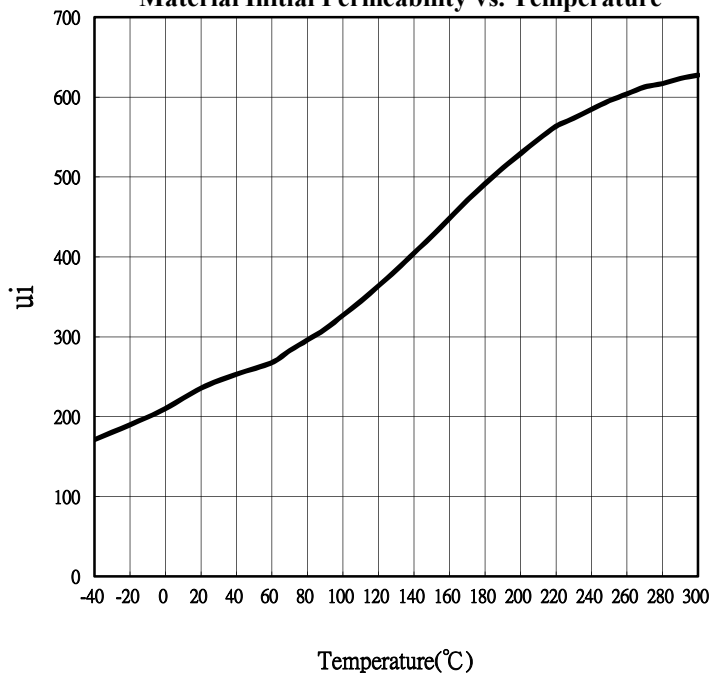

Measured on a 25/5/15mm toroid at 10KHz@B < 0.25 mT using the HP 4284A

**Material Relative Loss Factor vs. Frequency**

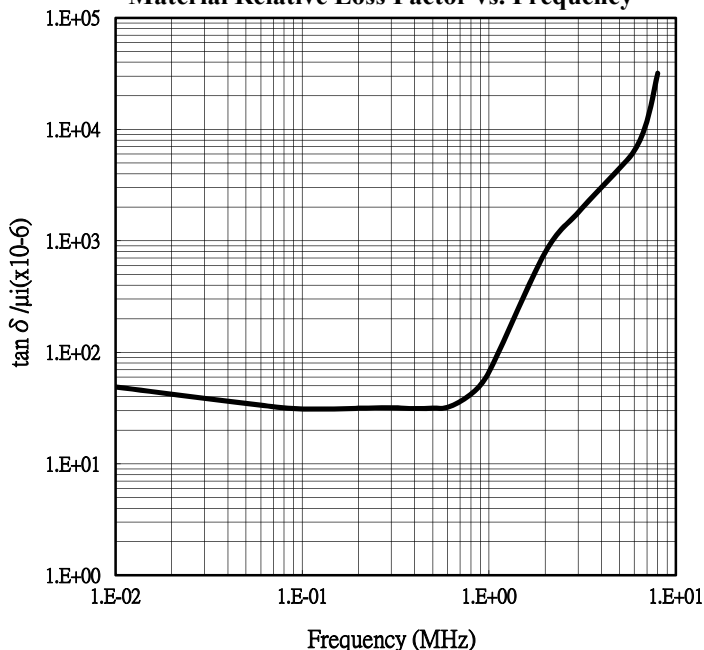

Measured on a 25/5/15mm toroid using the HP 4284A and E4991A

# J<sub>02</sub> Material

**Material Amplitude Permeability vs. Flux Density**

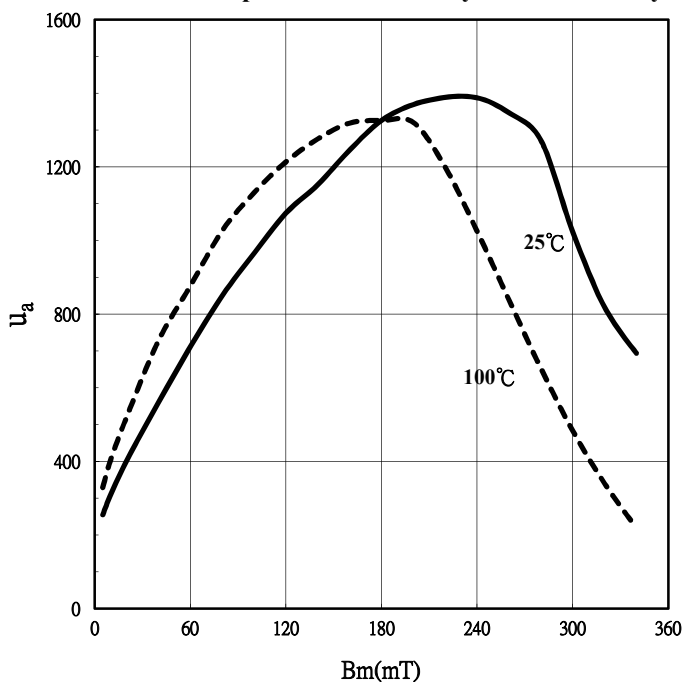

Measured on a 25/5/15mm toroid at 10KHz

**Material Power Loss Density vs. Flux Density**

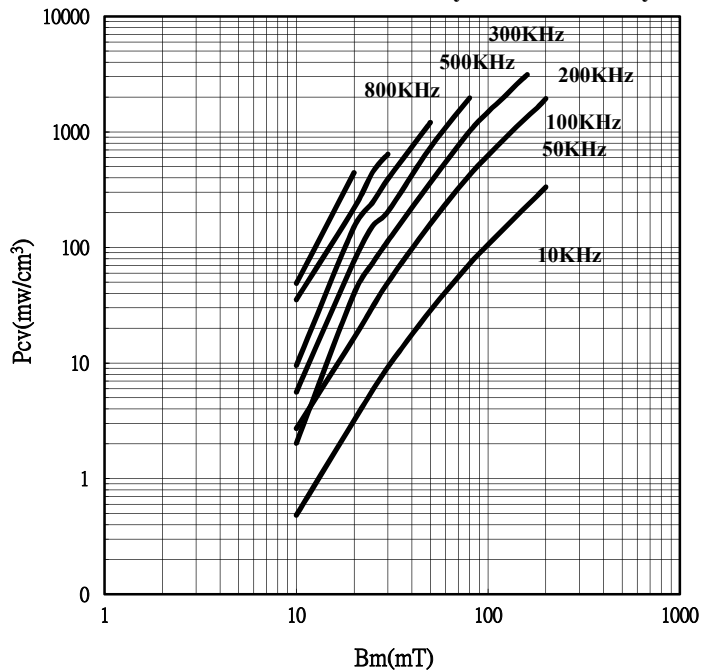

Measured on a 25/5/15mm toroid using the SY 8232 B-H ANALYZER at 25°C

**Material Power Loss Density vs. Temp.**

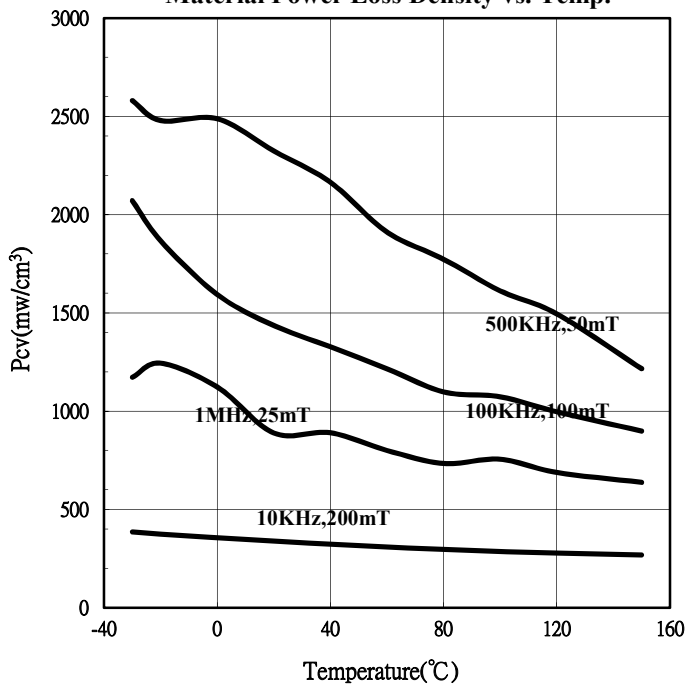

Measured on a 25/5/15mm toroid using the SY 8232 B-H ANALYZER

**Material Saturation Magnetic Flux Density vs. Temp.**

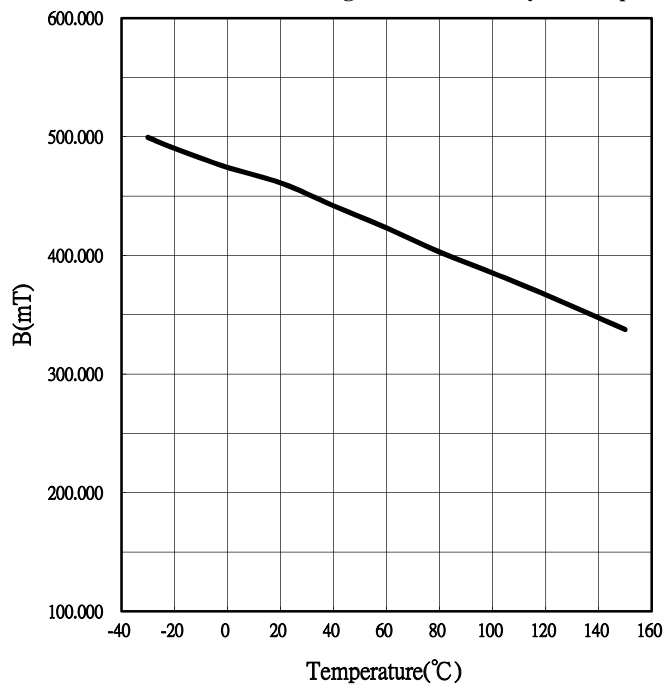

Measured on a 25/5/15mm toroid at 1KHz and H<sub>m</sub>=6000A/m

# F<sub>2D</sub> Material

**F<sub>2D</sub> Material Specifications**

Property	Unit	Symbol	Value
Initial Permeability (@B < 0.25 mT)		$\mu_i$	250
Saturation Magnetic Flux Density (@Field Strength)	mT	Bs	270
Remanent Flux Density	A/m	H	2400
Coercive Force	mT	Br	190
Relative Loss Factor (@Frequency)	A/m	Hc	64
Relative Loss Factor (@Frequency)	$10^{-6}$	$\tan \delta / \mu_i$	40
Temperature Factor of Initial Permeability(RT~70°C)	MHz		0.1
Temperature Factor of Initial Permeability(RT~70°C)	$10^{-6}/^{\circ}\text{C}$	$\alpha \mu_{ir}$	26
Curie Temperature	$^{\circ}\text{C}$	Tc	>180
Electrical Resistivity	$\Omega\text{-m}$	$\rho_v$	$10^6$

**Material Complex Permeability vs. Frequency**

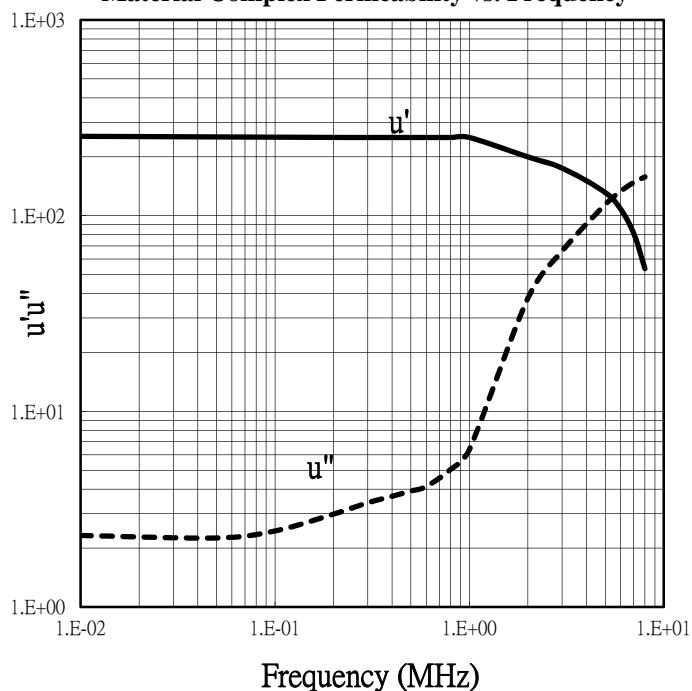

Measured on a 25/5/15mm toroid using the HP 4284A and E4991A

**Material Initial Permeability vs. Temperature**

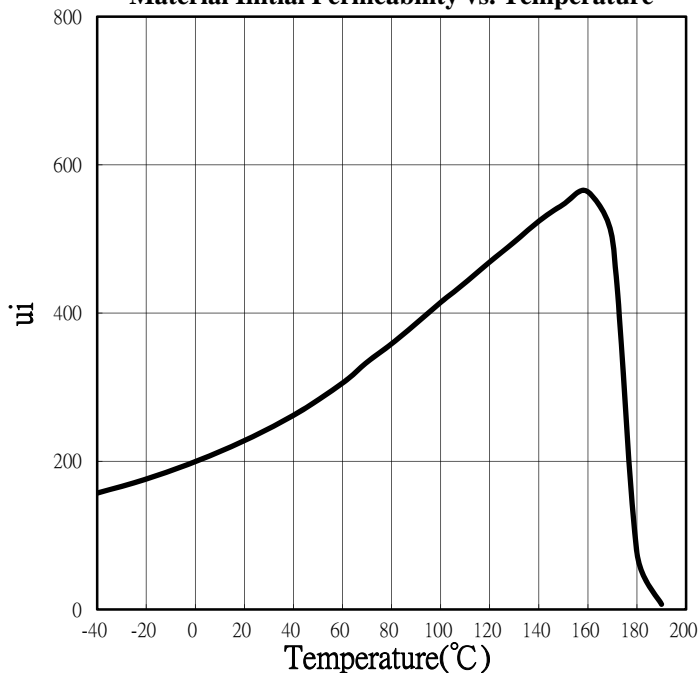

Measured on a 25/5/15mm toroid at 10KHz@B < 0.25 mT using the HP 4284A

**Material Relative Loss Factor vs. Frequency**

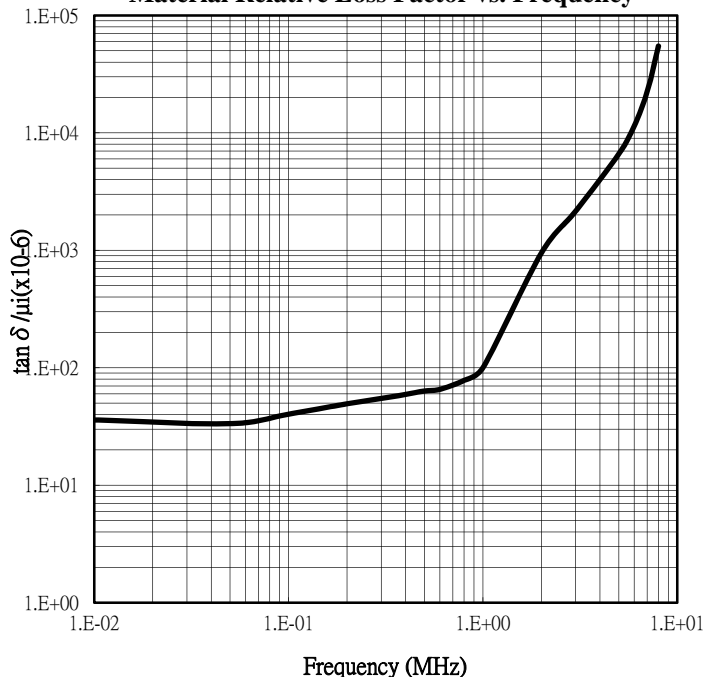

Measured on a 25/5/15mm toroid using the HP 4284A and E4991A

# X<sub>26</sub> Material

**X<sub>26</sub> Material Specifications**

Property	Unit	Symbol	Value
Initial Permeability (@B < 0.25 mT)		$\mu_i$	120
Saturation Magnetic Flux Density (@Field Strength)	mT	B <sub>s</sub>	300
Remanent Flux Density	A/m	H	2400
Coercive Force	mT	B <sub>r</sub>	200
Relative Loss Factor (@Frequency)	A/m	H <sub>c</sub>	160
Relative Loss Factor (@Frequency)	$10^{-6}$	$\tan \delta / \mu_i$	30
Temperature Factor of Initial Permeability(RT~70°C)	MHz		0.1
Temperature Factor of Initial Permeability(RT~70°C)	$10^{-6}/^{\circ}\text{C}$	$\alpha \mu_{ir}$	30
Curie Temperature	$^{\circ}\text{C}$	T <sub>c</sub>	>200
Electrical Resistivity	$\Omega\text{-m}$	$\rho_v$	$10^6$

**Material Complex Permeability vs. Frequency**

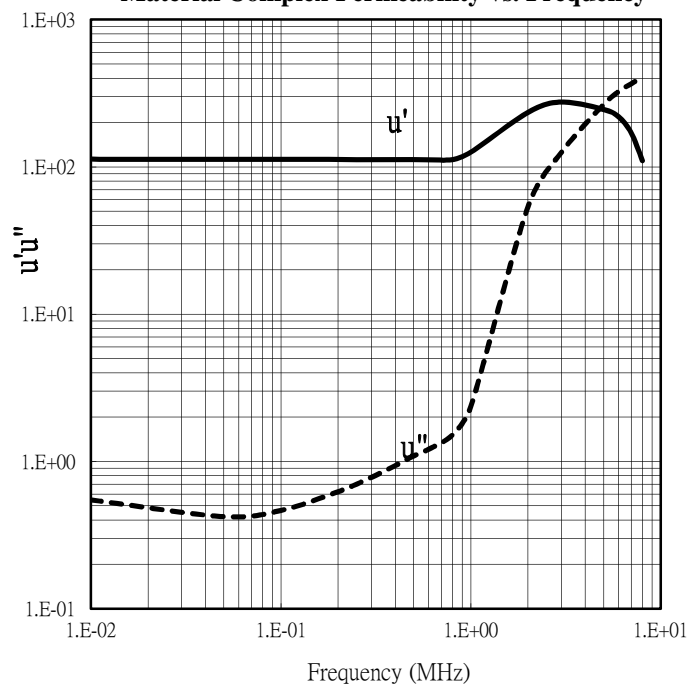

Measured on a 25/5/15mm toroid using the HP 4284A and E4991A

**Material Initial Permeability vs. Temperature**

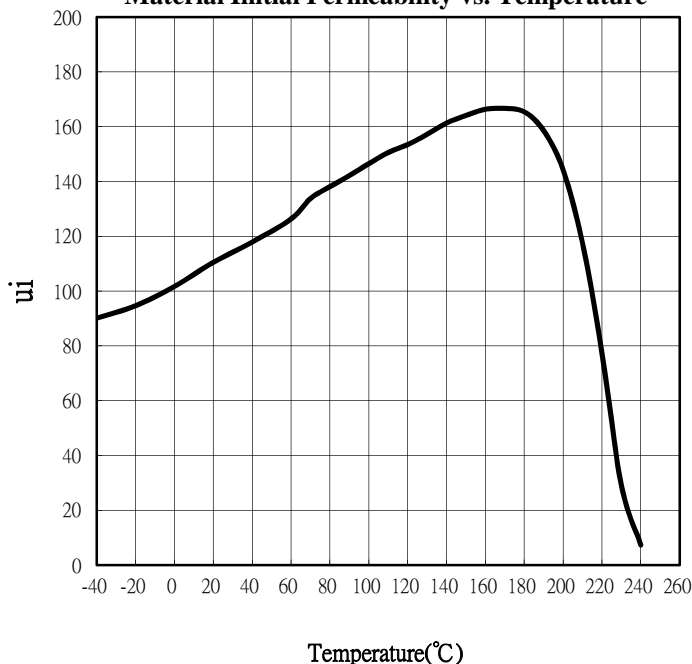

Measured on a 25/5/15mm toroid at 10KHz@B < 0.25 mT using the HP 4284A

**Material Relative Loss Factor vs. Frequency**

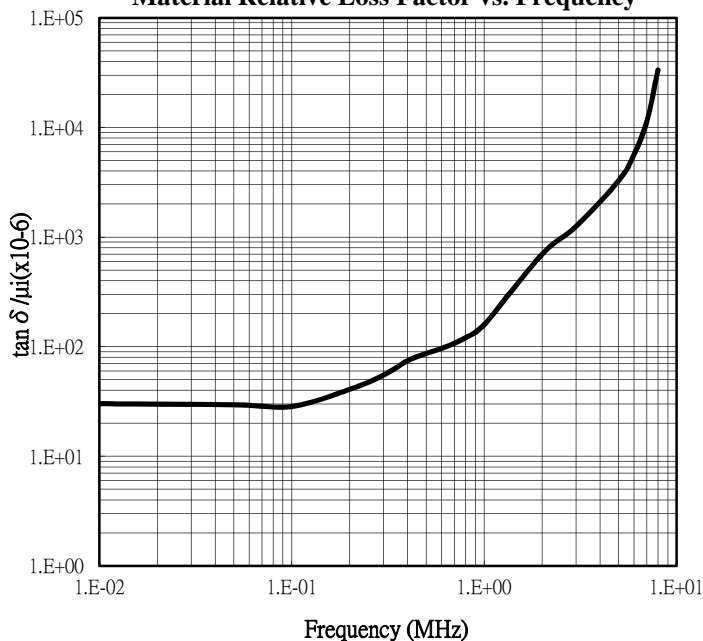

Measured on a 25/5/15mm toroid using the HP 4284A and E4991A

# F<sub>1</sub> Material

## F<sub>1</sub> Material Specifications

Property	Unit	Symbol	Value
Initial Permeability (@B < 0.25 mT)		$\mu_i$	100
Saturation Magnetic Flux Density (@Field Strength)	mT	B <sub>s</sub>	450
Remanent Flux Density	mT	B <sub>r</sub>	350
Coercive Force	A/m	H <sub>c</sub>	80
Relative Loss Factor (@Frequency)	10 <sup>-6</sup> MHz	$\tan \delta / \mu_i$	40 0.3
Temperature Factor of Initial Permeability(20~70°C)	10 <sup>-6</sup> /°C	$\alpha \mu_{ir}$	50
Curie Temperature	°C	T <sub>c</sub>	>300
Electrical Resistivity	Ω·m	$\rho_v$	10 <sup>6</sup>

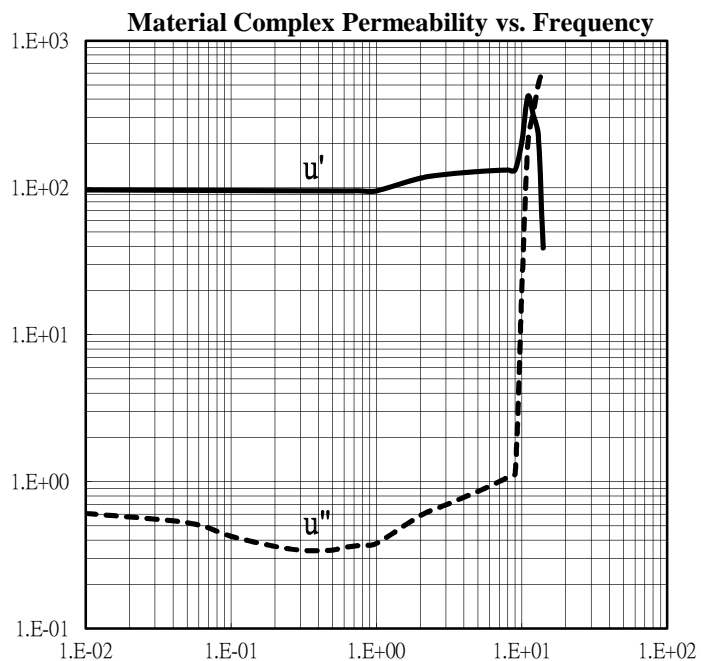

Measured on a 25/5/15mm toroid using the HP 4284A and E4991A

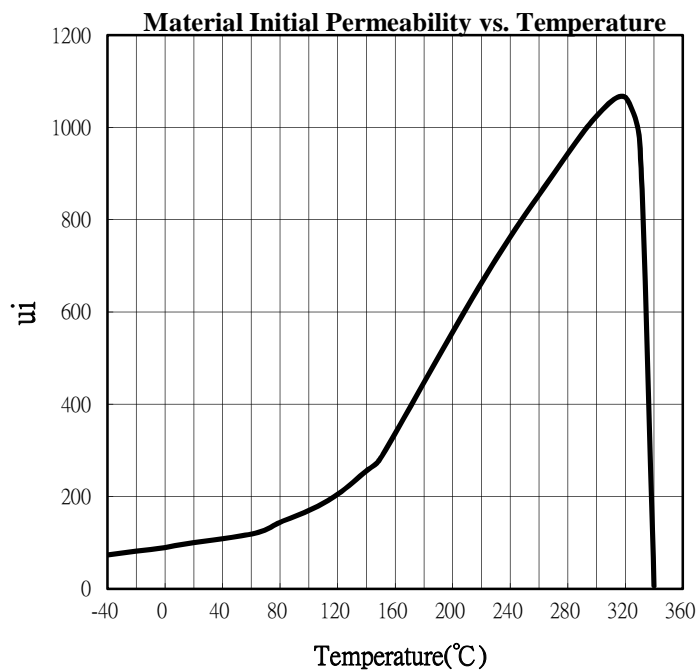

Measured on a 25/5/15mm toroid at 10KHz@B < 0.25 mT using the HP 4284A

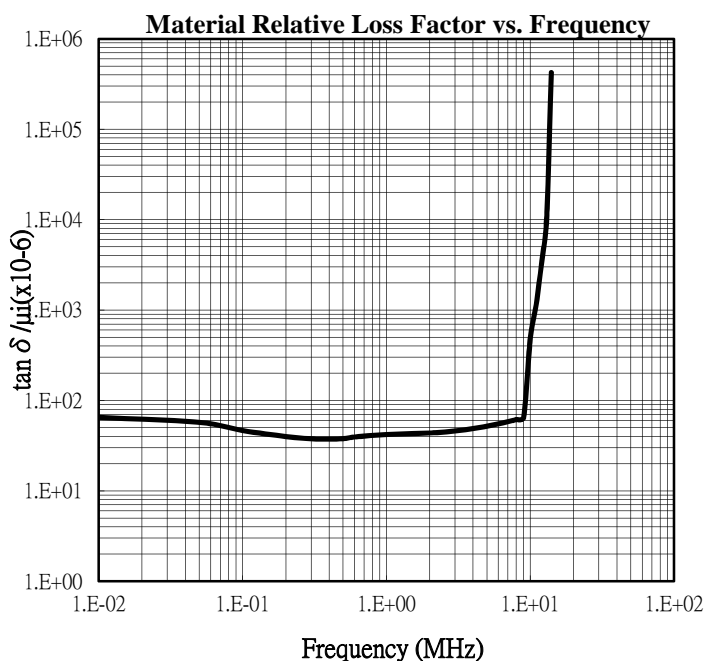

Measured on a 25/5/15mm toroid using the HP 4284A and E4991A

# X<sub>24</sub> Material

**X<sub>24</sub> Material Specifications**

Property	Unit	Symbol	Value
Initial Permeability (@B < 0.25 mT)		$\mu_i$	65
Saturation Magnetic Flux Density (@Field Strength)	mT	B <sub>s</sub>	300
Remanent Flux Density	A/m	H <sub>c</sub>	2800
Coercive Force	mT	Br	240
Relative Loss Factor (@Frequency)	A/m	H <sub>c</sub>	300
Relative Loss Factor (@Frequency)	10 <sup>-6</sup>	$\tan \delta / \mu_i$	70
Relative Loss Factor (@Frequency)	MHz		0.3
Temperature Factor of Initial Permeability(RT~70°C)	10 <sup>-6</sup> /°C	$\alpha \mu_{ir}$	45
Curie Temperature	°C	T <sub>c</sub>	>300
Electrical Resistivity	Ω-m	$\rho_v$	10 <sup>6</sup>

**Material Complex Permeability vs. Frequency**

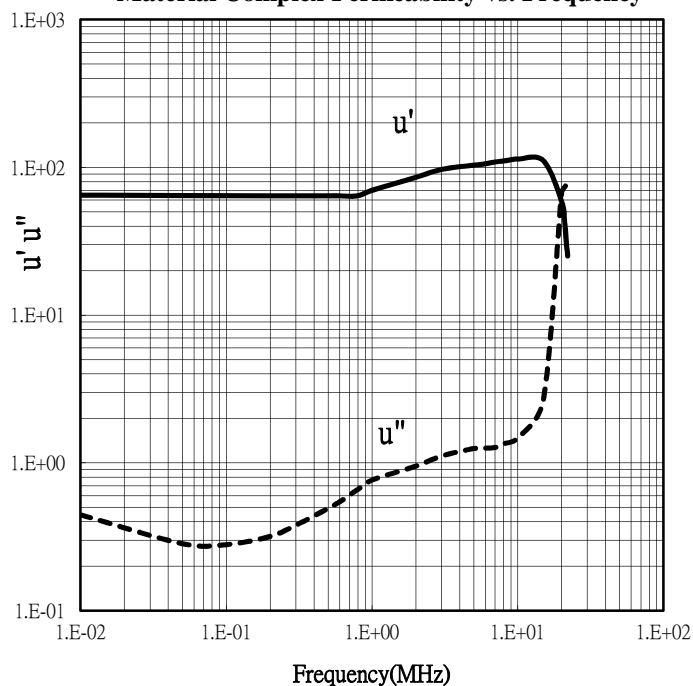

Measured on a 25/5/15mm toroid using the HP 4284A and E4991A

**Material Initial Permeability vs. Temperature**

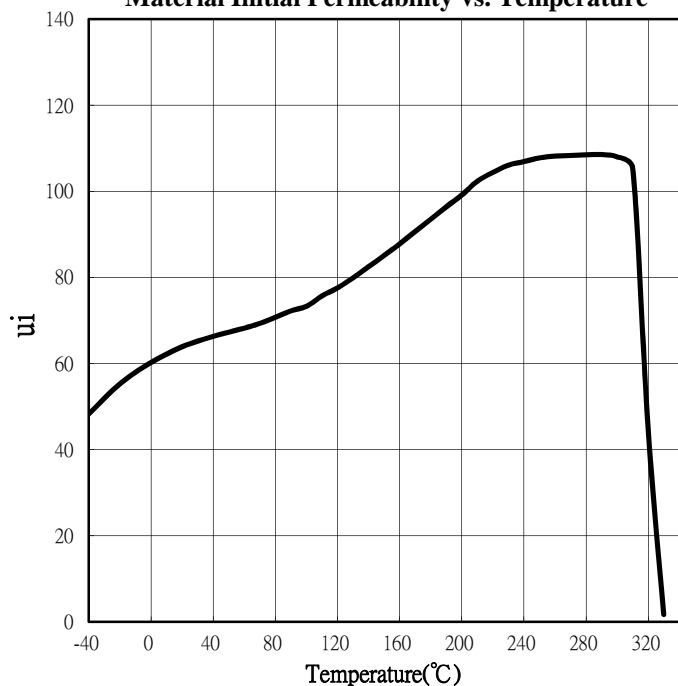

Measured on a 25/5/15mm toroid at 10KHz@B < 0.25 mT using the HP 4284A

**Material Relative Loss Factor vs. Frequency**

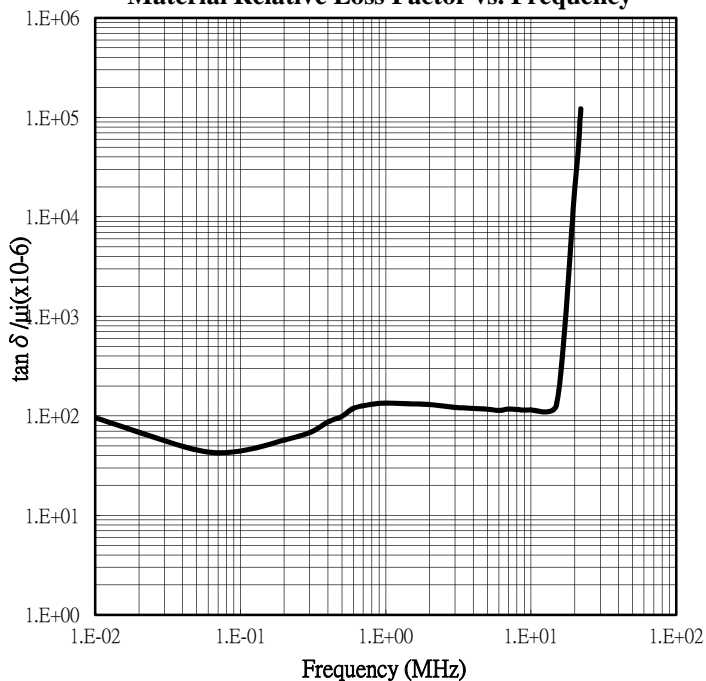

Measured on a 25/5/15mm toroid using the HP 4284A and E4991A

# BF : AT SERIES

## (BEAD CORES AXIAL TAPPING)

### 1. ORDERING CODE

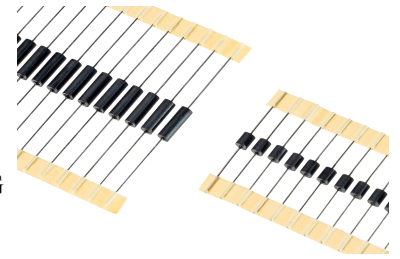
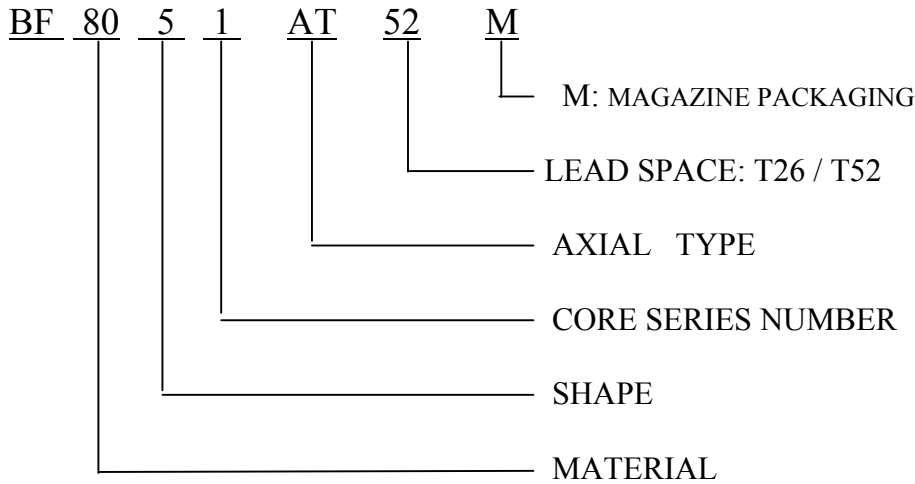

### 2. SHAPES

Unit: mm

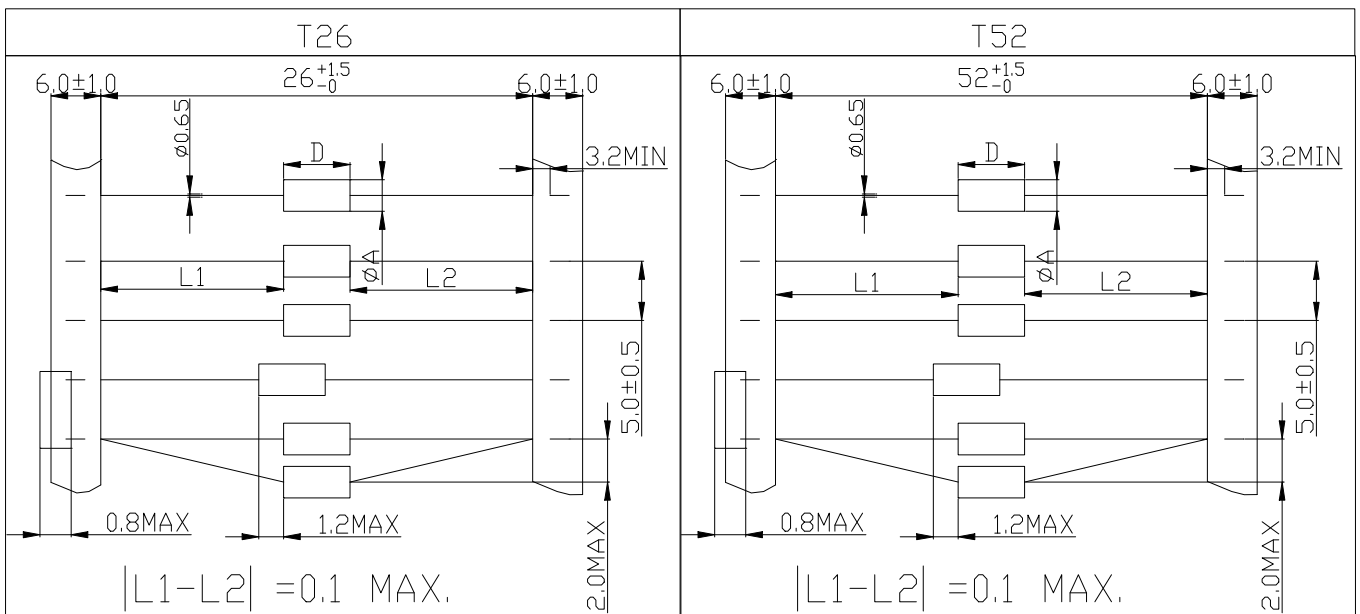

# BF : AT SERIES

## (BEAD CORES AXIAL TAPPING)

### 3.DIMENSIONS

NO.	FERRICO PART NO.	ΦA(mm)	D(mm)	ød(mm)	IMPEDANCE(Ω) TYP. /100MHz	Rated Current (A)
1	BF 805RAT52M	2.5±0.2	2.5±0.2	0.65	40	7
2	BF 805AJAT52M	2.5±0.2	3.0±0.2	0.65	44	7
3	BF 805WAT52M	2.5±0.2	4.0±0.3	0.65	51	7
4	BF 805QAT52M	3.5±0.2	2.5±0.2	0.65	44	7
5	BF 8051AT52M	3.5±0.2	4.4±0.3	0.65	65	7
6	BF 8056AT52M	3.5±0.2	5.0±0.2	0.65	70	7
7	BF 8056AT26M	3.5±0.2	5.0±0.2	0.65	66	7
8	BF 8052AT52M	3.5±0.2	6.0±0.2	0.65	77	7
9	BF 8052AT26M	3.5±0.2	6.0±0.2	0.65	74	7
10	BF 8053AT52M	3.5±0.2	8.0±0.3	0.65	100	7
11	BF 8053AT26M	3.5±0.2	8.0±0.3	0.65	97	7
12	BF 8054AT52M	3.5±0.2	9.0±0.3	0.65	117	7
13	BF 8054AT26M	3.5±0.2	9.0±0.3	0.65	113	7
14	BF 805JAT52M	3.5±0.2	10.0±0.5	0.65	137	7
15	BF 805JAT26M	3.5±0.2	10.0±0.5	0.65	122	7
16	BF 805DAT52M	3.5±0.2	12.0±0.5	0.65	144	7
17	BF 805EAT52M	3.5±0.2	14.0±0.5	0.65	175	7

REMARK : OTHER SIZES ARE AVAILABLE UPON REQUEST

# BF : RT SERIES (BEAD CORE RADIAL TAPPING)

## 1. ORDERING CODE

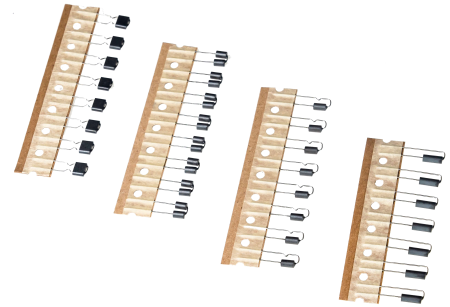
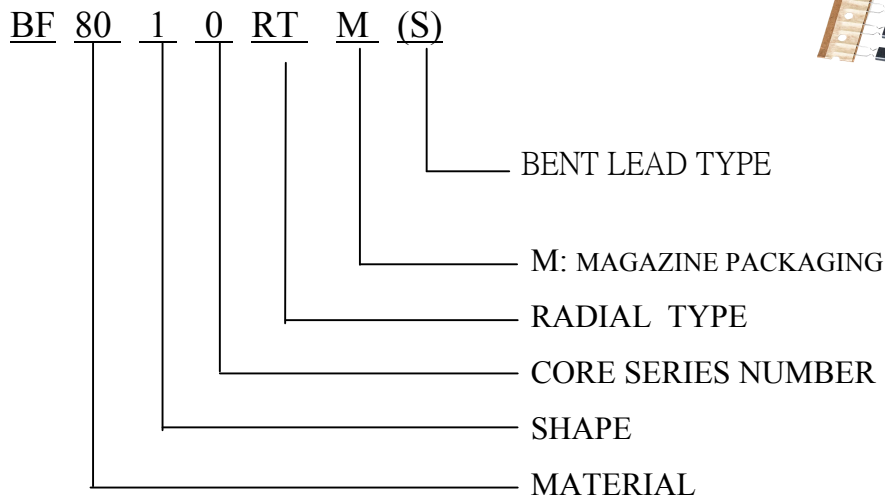

## 2. SHAPES

Unit: mm

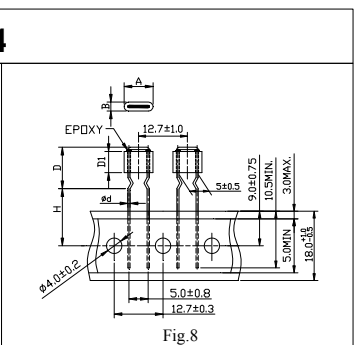
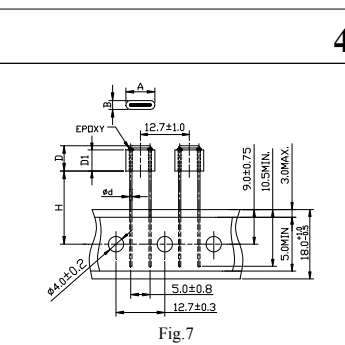
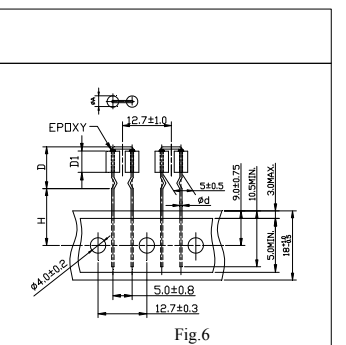
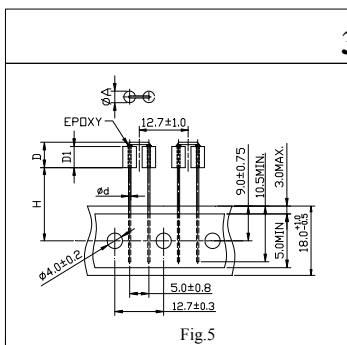
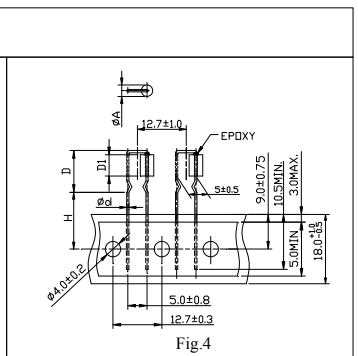
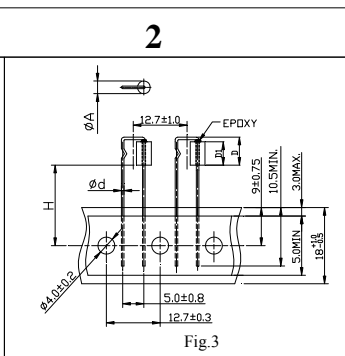
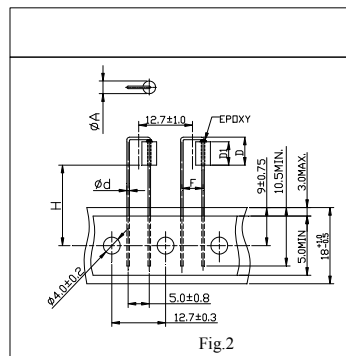
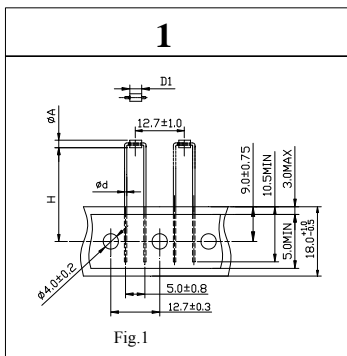

# BF : RT SERIES

## (BEAD CORE RADIAL TAPPING)

### 3.DIMENSIONS

NO.	FERRICO PART NO.	FIG.	ΦA/A (mm)	B (mm)	D (mm)	D1 (mm)	Ød (mm)	H (mm)	IMPEDANCE(Ω) TYP./100MHz	Rated Current (A)
1	BF 801WRTM	1	2.5±0.2			4.0±0.3	0.65	18.5 <sup>+1.0</sup> <sub>-0.5</sub>	45	7
2	BF 802LRTM	2	3.5±0.2		6.0MAX.	3.0±0.2	0.65	18.5 <sup>+1.0</sup> <sub>-0.5</sub>	40	7
3	BF 8026RTM	2	3.5±0.2		7.5MAX.	5.0±0.2	0.65	18.5 <sup>+1.0</sup> <sub>-0.5</sub>	68	7
4	BF 8026RTM(S)	4	3.5±0.2		12.0MAX.	5.0±0.2	0.65	13.0±1.0	68	7
5	BF 8026RTM(S)	3	3.5±0.2		7.5MAX.	5.0±0.2	0.65	18.5 <sup>+1.0</sup> <sub>-0.5</sub>	68	7
6	BF 8022RTM	2	3.5±0.2		9.0MAX.	6.0±0.3	0.65	18.5 <sup>+1.0</sup> <sub>-0.5</sub>	70	7
7	BF 8024RTM	2	3.5±0.2		12.0MAX.	9.0±0.3	0.65	18.5 <sup>+1.0</sup> <sub>-0.5</sub>	110	7
8	BF 803WRTM	5	2.5±0.2		6.5MAX.	4.0±0.3	0.65	18.5 <sup>+1.0</sup> <sub>-0.5</sub>	80	7
9	BF 8036RTM	5	3.5±0.2		7.5MAX.	5.0±0.2	0.65	18.5 <sup>+1.0</sup> <sub>-0.5</sub>	125	7
10	BF 8036RTM(S)	6	3.5±0.2		12.0MAX.	5.0±0.2	0.65	13.0±1.0	125	7
11	BF 8030RTM	5	3.5±0.2		7.7MAX.	5.2±0.2	0.65	18.5 <sup>+1.0</sup> <sub>-0.5</sub>	127	7
12	BF 8032RTM	5	3.5±0.2		8.5MAX.	6.0±0.2	0.65	18.5 <sup>+1.0</sup> <sub>-0.5</sub>	150	7
13	BF 803ACRTM	5	3.5±0.2		8.3MAX.	6.5±0.3	0.65	18.5 <sup>+1.0</sup> <sub>-0.5</sub>	160	7
14	BF 8033RTM	5	3.5±0.2		11.0MAX.	8.0±0.3	0.65	18.5 <sup>+1.0</sup> <sub>-0.5</sub>	200	7
15	BF 804HRTM	7	6.0±0.2	3.0±0.2	7.0MAX.	5.0±0.2	0.65	18.5 <sup>+1.0</sup> <sub>-0.5</sub>	110	7
16	BF 8047RTM	7	7.5±0.2	2.3±0.2	7.0MAX.	5.5±0.3	0.60	19.0±1.0	110	6
17	BF 8047RTM(S)	8	7.5±0.2	2.3±0.2	12.5MAX.	5.5±0.3	0.60	14.5±1.0	110	6
18	BF 8046RTM	7	7.5±0.2	2.3±0.2	8.0MAX.	6.0±0.3	0.60	18.5 <sup>+1.0</sup> <sub>-0.5</sub>	120	6
19	BF 804DRTM	7	7.5±0.2	2.3±0.2	9.8MAX.	7.5±0.5	0.60	19.0±1.0	150	6
20	BF 804ARTM	7	7.5±0.2	2.3±0.2	9.8MAX.	7.8±0.5	0.60	18.5 <sup>+1.0</sup> <sub>-0.5</sub>	150	6
21	BF 804ARTM(S)	8	7.5±0.2	2.3±0.2	16.0MAX.	7.8±0.5	0.60	18.0±2.0	150	6
22	BF 8040RTM	7	8.0±0.5	2.5±0.3	7.0MAX.	5.0±0.2	0.60	18.5 <sup>+1.0</sup> <sub>-0.5</sub>	120	6

REMARK : OTHER SIZES ARE AVAILABLE UPON REQUEST

# BF : AT SERIES (BEAD CORE AXIAL TAPPING)

ITEM: BF 805RAT52M  
Z-F RESPONSE

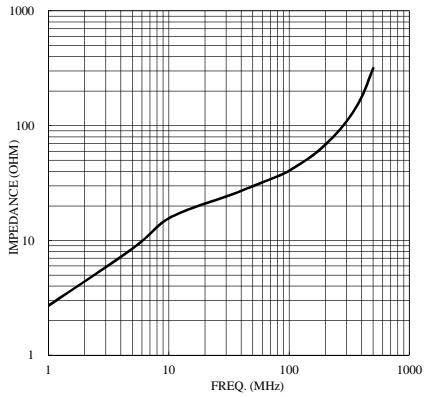

ITEM: BF 805WAT52M  
Z-F RESPONSE

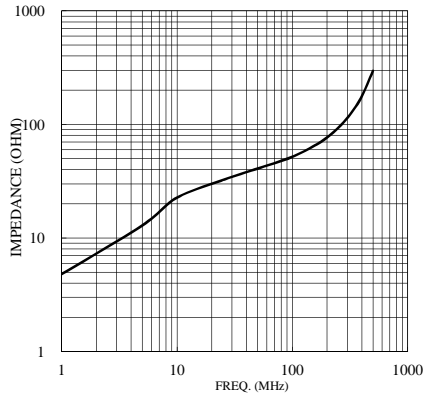

ITEM: BF 805QAT52M  
Z-F RESPONSE

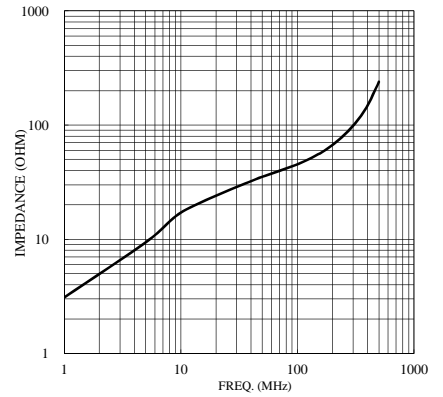

ITEM: BF 8051AT52M  
Z-F RESPONSE

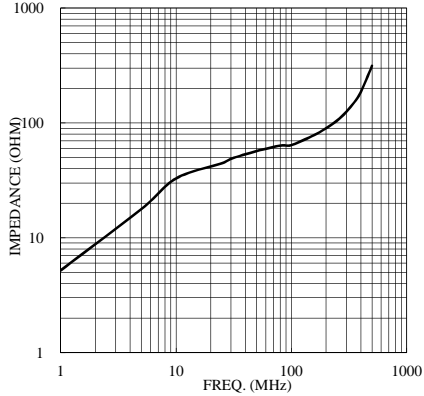

ITEM: BF 8056AT52M  
Z-F RESPONSE

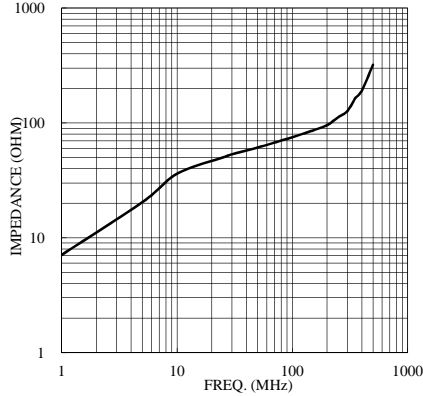

ITEM: BF 8052AT52M  
Z-F RESPONSE

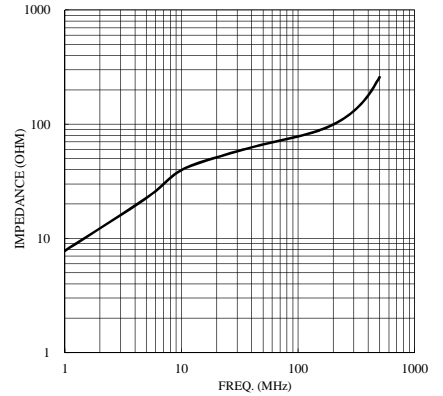

ITEM: BF 8053AT52M  
Z-F RESPONSE

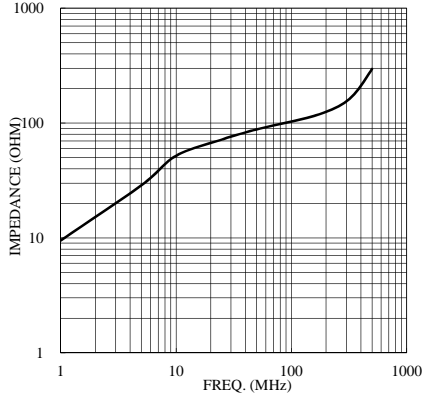

ITEM: BF 8054AT52M  
Z-F RESPONSE

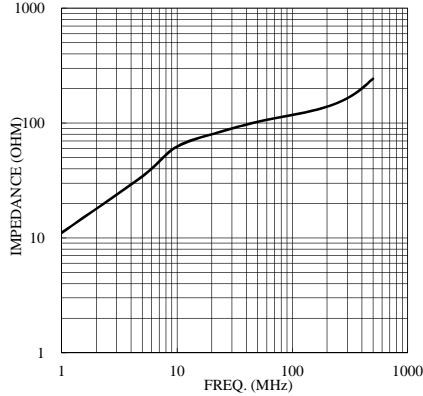

ITEM: BF 805JAT52M  
Z-F RESPONSE

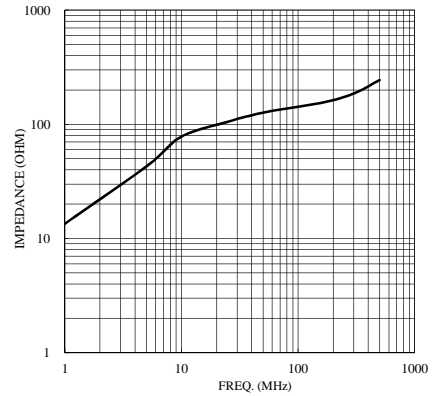

ITEM: BF 805AHAT52M  
Z-F RESPONSE

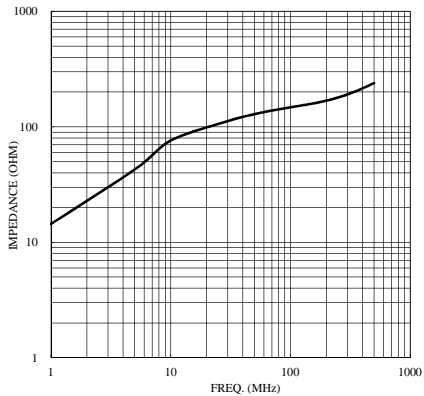

ITEM: BF 805DAT52M  
Z-F RESPONSE

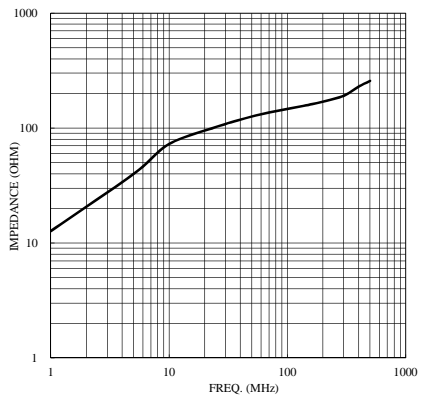

ITEM: BF 805EAT52M  
Z-F RESPONSE

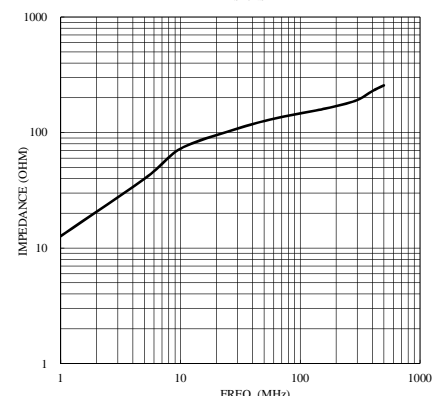

# BF : RT SERIES (BEAD CORE RADIAL TAPPING)

ITEM: BF 801WRTM  
Z-F RESPONSE

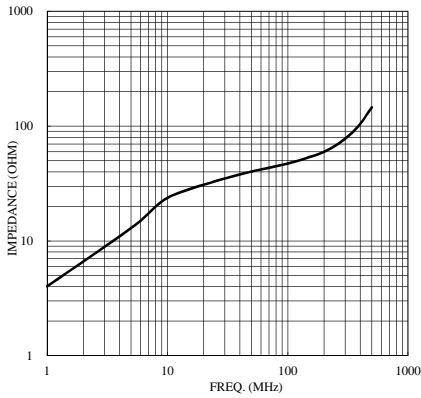

ITEM: BF 802LRTM  
Z-F RESPONSE

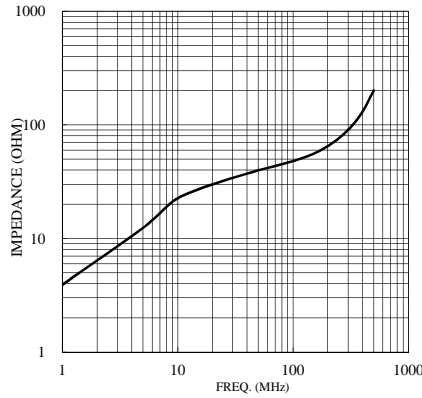

ITEM: BF 8026RTM  
Z-F RESPONSE

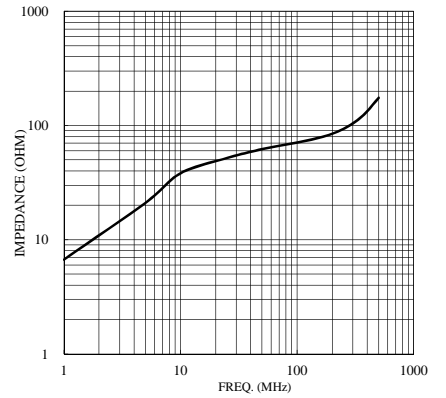

ITEM: BF 8022RTM  
Z-F RESPONSE

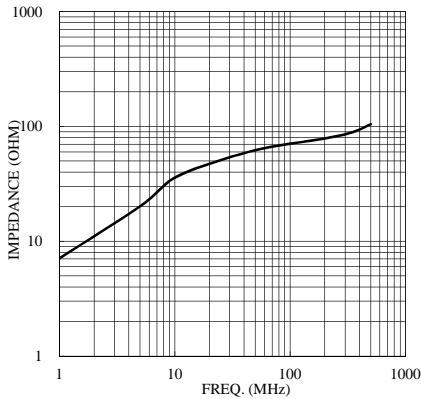

ITEM: BF 8024RTM  
Z-F RESPONSE

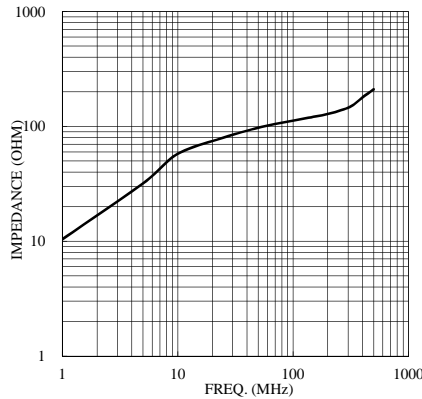

ITEM: BF 803WRTM  
Z-F RESPONSE

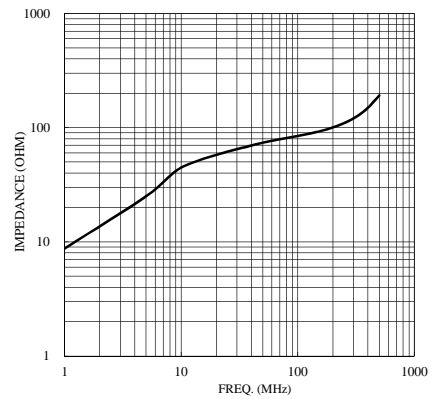

ITEM: BF 8030RTM  
Z-F RESPONSE

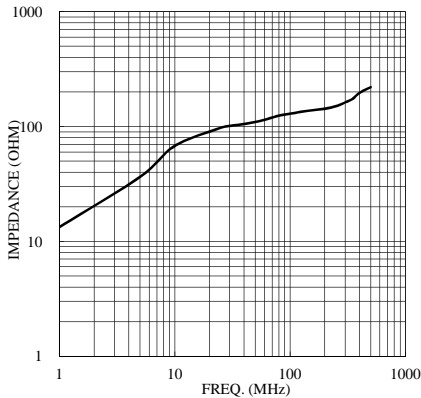

ITEM: BF 803ACRTM  
Z-F RESPONSE

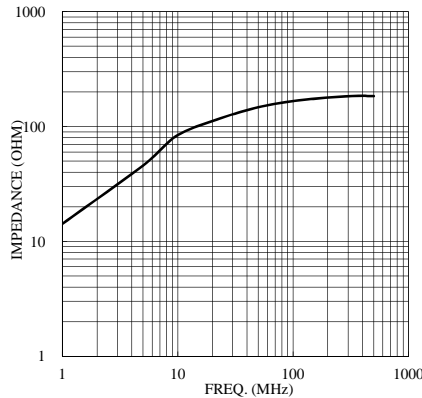

ITEM: BF 8033RTM  
Z-F RESPONSE

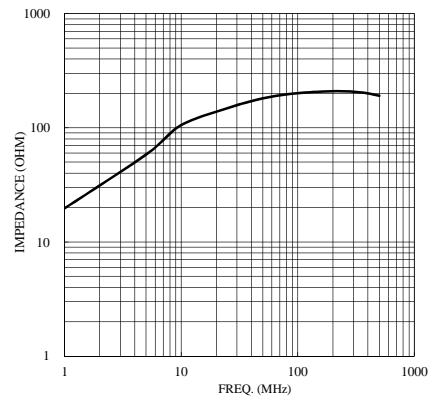

ITEM: BF 8047RTM  
Z-F RESPONSE

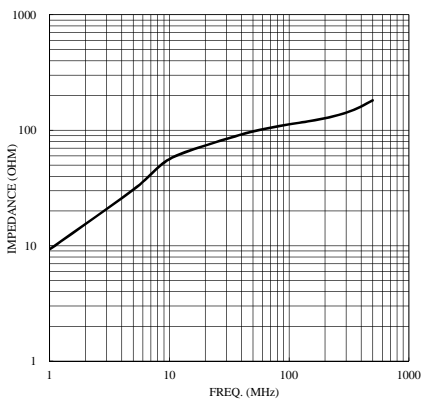

ITEM: BF 8046RTM  
Z-F RESPONSE

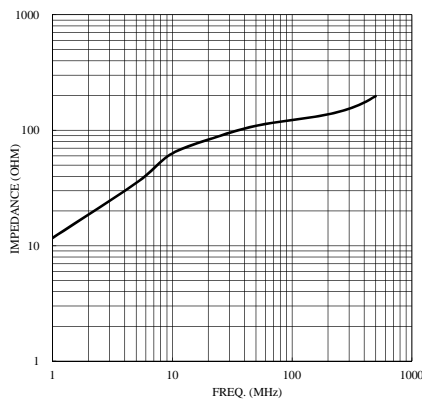

ITEM: BF 804ARTM  
Z-F RESPONSE

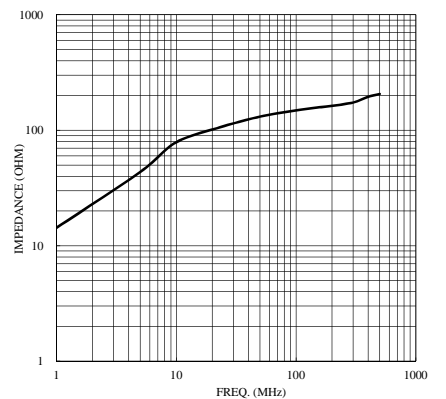

# FF SERIES

## (FLAT CABLE SUPPRESSION CORES)

### 1. ORDERING CODE

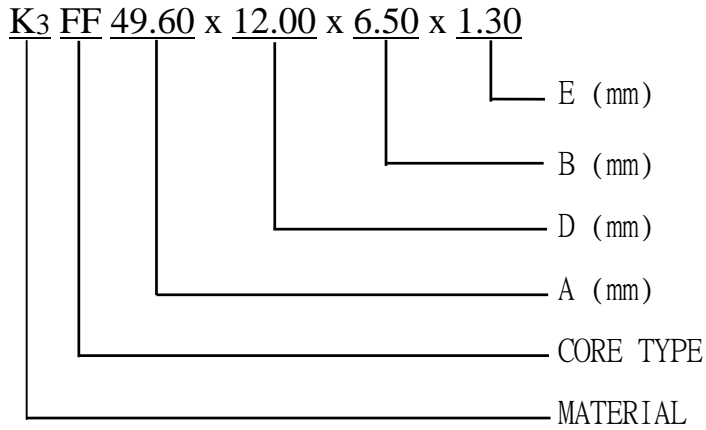

### 2. SHAPES

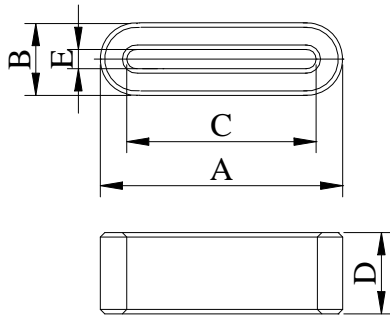

Fig. 1

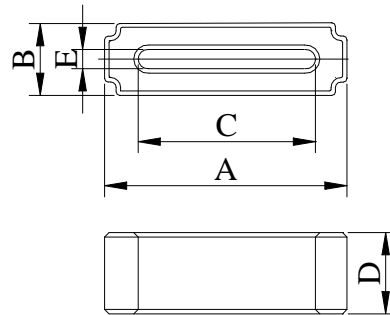

Fig. 2

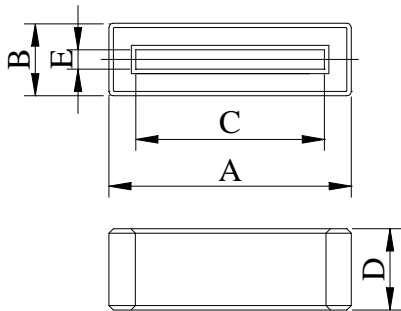

Fig. 3

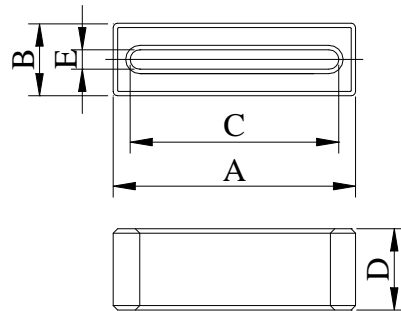

Fig. 4

# FF SERIES

## (FLAT CABLE SUPPRESSION CORES)

### 3. DIMENSIONS

Unit:mm

NO.	FERRICO PART NO.	Fig.	A	B	C	D	E	APPLICABLE CABLE (WIDE)	IMPEDANCE( $\Omega$ )	
									TYP.	
									25 MHz	100 MHz
1	K3 FF 800x900x270x070	4	80 $\pm$ 03	27 $\pm$ 03	60 $\pm$ 025	90 $\pm$ 03	07 $\pm$ 025	MAX.50	37	91
2	K3 FF 850x500x200x060	1	85 $\pm$ 03	20 $\pm$ 02	60 $\pm$ 02	50 $\pm$ 03	06 $\pm$ 02	MAX.50	23	74
3	K3 FF 950x800x210x060	4	95 $\pm$ 03	21 $\pm$ 025	70 $\pm$ 03	80 $\pm$ 03	06 $\pm$ 02	MAX.60	28	87
4	K3 FF 980x800x330x080	1	98 $\pm$ 06	33 $\pm$ 05	73 $\pm$ 06	80 $\pm$ 05	08 $\pm$ 04	MAX.60	32	80
5	K3 FF 1000x2000x701x400	3	100 $\pm$ 05	701 $\pm$ 04	70 $\pm$ 04	200 $\pm$ 05	40 $\pm$ 04	MAX.60	57	98
6	K3 FF 1050x500x210x060	4	105 $\pm$ 03	21 $\pm$ 025	80 $\pm$ 03	50 $\pm$ 03	06 $\pm$ 02	MAX.70	25	81
7	K3 FF 1150x200x300x070	4	115 $\pm$ 03	30 $\pm$ 03	80 $\pm$ 03	20 $\pm$ 02	07 $\pm$ 02	MAX.70	15	57
8	K3 FF 1350x600x200x050	1	135 $\pm$ 04	20 $\pm$ 05	110 $\pm$ 04	60 $\pm$ 03	05 $\pm$ <sub>0</sub> <sup>04</sup>	MAX.100	16	48
9	K3 FF 1350x1500x275x070	4	135 $\pm$ 03	275 $\pm$ 03	110 $\pm$ 03	150 $\pm$ 05	07 $\pm$ 03	MAX.100	43	118
10	K3 FF 1380x300x500x080	1	138 $\pm$ 04	50 $\pm$ 04	96 $\pm$ 04	30 $\pm$ 03	08 $\pm$ 04	MAX85	21	63
11	K3 FF 1387x200x365x095	1	1387 $\pm$ 03	365 $\pm$ 03	100 $\pm$ 03	20 $\pm$ 03	09 $\pm$ <sub>0.2</sub> <sup>0.1</sup>	MAX90	17	61
12	K3 FF 1400x600x550x330	1	140 $\pm$ 04	55 $\pm$ 05	120 $\pm$ 04	60 $\pm$ 03	33 $\pm$ <sub>0</sub> <sup>04</sup>	MAX110	20	63
13	K3 FF 1400x500x800x400	1	140 $\pm$ 04	80 $\pm$ 05	100 $\pm$ 03	50 $\pm$ 03	40 $\pm$ 05	MAX90	23	63
14	K3 FF 1400x1250x800x430	1	140 $\pm$ 04	80 $\pm$ 05	100 $\pm$ 03	125 $\pm$ 05	43 $\pm$ 05	MAX90	42	82
15	K3 FF 1400x1500x900x400	3	140 $\pm$ 05	90 $\pm$ 05	90 $\pm$ 04	150 $\pm$ 03	40 $\pm$ 04	MAX.80	54	93
16	K3 FF 1550x1000x340x140	1	155 $\pm$ 04	34 $\pm$ 04	135 $\pm$ 04	100 $\pm$ 03	14 $\pm$ 05	MAX.125	26	75
17	K3 FF 1560x1200x185x070	4	156 $\pm$ 05	185 $\pm$ <sub>12</sub> <sup>05</sup>	136 $\pm$ 04	120 $\pm$ 04	07 $\pm$ <sub>12</sub> <sup>05</sup>	MAX.125	35	94
18	K3 FF 1600x900x500x050	1	160 $\pm$ 05	50 $\pm$ <sub>07</sub> <sup>0</sup>	115 $\pm$ 04	90 $\pm$ 05	05 $\pm$ <sub>0</sub> <sup>06</sup>	MAX.105	37	86
19	K3 FF 1600x1000x400x080	1	160 $\pm$ 04	40 $\pm$ 04	115 $\pm$ 04	100 $\pm$ 05	08 $\pm$ 03	MAX.105	39	101
20	K3 FF 1600x1200x500x050	1	160 $\pm$ 05	50 $\pm$ <sub>07</sub> <sup>0</sup>	115 $\pm$ 04	120 $\pm$ 05	05 $\pm$ <sub>0</sub> <sup>06</sup>	MAX.105	46	92
21	K3 FF 1600x1200x500x130	1	160 $\pm$ 04	50 $\pm$ 03	115 $\pm$ 04	120 $\pm$ 05	13 $\pm$ 02	MAX.105	41	95
22	K3 FF 1650x400x410x080	1	165 $\pm$ 04	41 $\pm$ 04	120 $\pm$ 04	40 $\pm$ 04	08 $\pm$ 025	MAX110	24	77
23	K3 FF 1660x2000x375x070	1	166 $\pm$ 05	375 $\pm$ 04	130 $\pm$ 04	200 $\pm$ 05	07 $\pm$ 03	MAX.120	50	119
24	K3 FF 1660x1200x375x100	1	166 $\pm$ 05	375 $\pm$ 04	130 $\pm$ 04	120 $\pm$ 04	10 $\pm$ 03	MAX.120	36	96
25	K3 FF 1700x1200x280x070	1	170 $\pm$ 05	28 $\pm$ 03	130 $\pm$ 05	120 $\pm$ 05	07 $\pm$ 03	MAX.120	33	92
26	K3 FF 1700x1000x450x150	1	170 $\pm$ 03	45 $\pm$ 03	140 $\pm$ 03	100 $\pm$ 04	15 $\pm$ 03	MAX.130	32	85
27	K3 FF 1700x900x500x080	1	170 $\pm$ 04	50 $\pm$ 04	134 $\pm$ 04	90 $\pm$ 03	08 $\pm$ 04	MAX.125	34	75
28	K3 FF 1700x1200x500x080	1	170 $\pm$ 04	50 $\pm$ 04	134 $\pm$ 04	120 $\pm$ 04	08 $\pm$ 04	MAX.125	46	106
29	K3 FF 1700x1200x500x100	1	170 $\pm$ 04	50 $\pm$ 04	134 $\pm$ 04	120 $\pm$ 04	10 $\pm$ 02	MAX.125	43	101
30	K3 FF 1700x1000x700x400	3	170 $\pm$ 03	70 $\pm$ 03	140 $\pm$ 03	100 $\pm$ 04	40 $\pm$ 03	MAX.130	25	66

# FF SERIES

## (FLAT CABLE SUPPRESSION CORES)

Unit:mm

NO.	FERRICO PART NO.	Fig.	A	B	C	D	E	APPLICABLE CABLE (WIDE)	IMPEDANCE(Ω)	
									TYP.	
									25 MHz	100 MHz
31	K3 FF 1785x1720x835x550	4	1785 <sup>+015</sup> <sub>-04</sub>	835±03	1345±03	172±03	55 <sup>+0</sup> <sub>-08</sub>	MAX.125	41	86
32	K3 FF 1800x800x230x070	1	180±03	23±02	150±03	80±04	07±02	MAX.140	21	59
33	K3 FF 1800x800x500x1.00	1	180±05	50±03	140±05	80±03	1.0±03	MAX.130	32	88
34	K3 FF 1800x1000x450x1.50	1	180±03	45±03	150±04	100±04	1.5±03	MAX.140	31	85
35	K3 FF 1850x1200x400x1.00	1	185±04	40±03	150±04	120±05	1.0±03	MAX.140	37	100
36	K3 FF 1880x900x590x1.60	1	188±04	59±03	146±04	90±03	1.6±03	MAX.136	33	83
37	K3 FF 1900x1200x400x1.00	1	190±08	40±04	135±05	120±05	1.0±03	MAX.125	37	99
38	K3 FF 1900x1500x400x1.50	1	190±08	40±04	135±05	150±05	1.5±03	MAX.125	40	100
39	K3 FF 1900x1200x650x1.00	1	190±08	65±05	134±05	120±05	1.0±03	MAX.125	51	116
40	K3FF 1900x1200x650x1.50	1	190±08	65±05	1345±05	120±05	1.5±03	MAX.125	47	102
41	K3 FF 1900x1200x650x1.80	1	190±08	65±05	140±05	120±05	1.8±03	MAX.130	45	96
42	K3 FF 1900x2000x450x0.5	1	190±1.0	45±05	150±0.7	200±0.5	0.5 <sup>+0.5</sup> <sub>0</sub>	MAX.140	66	165
43	K3 FF 1930x2860x760x1.30	1	193±0.8	76±0.5	130±0.5	286±0.8	1.3±0.4	MAX.120	124	218
44	K3 FF 2000x750x500x1.30	1	200±0.5	50±0.4	156±0.5	75±0.5	1.3 <sup>+0.5</sup> <sub>0.3</sub>	MAX.145	27	78
45	K3 FF 2000x1200x650x1.30	1	200±0.5	65±0.5	150±0.5	120±0.5	1.3 <sup>+0.5</sup> <sub>0.3</sub>	MAX.140	46	104
46	K3 FF 2050x1500x350x0.70	3	205±0.6	35±0.5	165±0.5	150±0.5	0.7 <sup>+0.25</sup> <sub>-0.15</sub>	MAX.155	39	112
47	K3 FF 2130x2200x650x1.40	1	2131±0.5	65±0.5	160±0.5	220±0.8	1.4±0.3	MAX.150	72	144
48	K3 FF 2150x900x500x0.50	1	215±0.5	50 <sup>+0</sup> <sub>-0.7</sub>	170±0.5	90±0.5	0.5 <sup>+0.5</sup> <sub>0</sub>	MAX.160	37	108
49	K3 FF 2150x600x300x0.70	3	215±0.4	30±0.3	185±0.4	60±0.3	0.7±0.3	MAX.175	24	76
50	K3 FF 2150x600x400x0.80	1	215±0.5	40±0.3	175±0.5	60±0.3	0.8±0.3	MAX.165	25	79
51	K3 FF 2150x800x500x0.80	1	215±0.5	50 <sup>+0</sup> <sub>-0.7</sub>	170±0.5	80±0.5	0.8 <sup>+0.5</sup> <sub>0</sub>	MAX.160	30	81
52	K3 FF 2200x500x300x1.00	1	220±0.5	30±0.4	180±0.5	50±0.5	1.0±0.3	MAX.170	20	67
53	K3 FF 2270x600x175x0.60	4	227±0.5	175 <sup>+0.5</sup> <sub>-0.2</sub>	206±0.5	60±0.3	0.6 <sup>+0.5</sup> <sub>-0.2</sub>	MAX.195	24	77
54	K3 FF 2280x600x280x0.70	4	228±0.5	28±0.3	187±0.5	60±0.3	0.7±0.3	MAX.175	24	78
55	K3 FF 2300x610x400x1.00	4	230±0.5	40±0.4	180±0.5	61±0.5	1.0 <sup>+0.4</sup> <sub>-0.3</sub>	MAX.170	24	77
56	K3 FF 2300x750x600x1.00	1	230±0.6	60±0.4	180±0.6	75±0.4	1.0±0.4	MAX.170	33	90
57	K3 FF 2330x1200x300x0.70	4	230±0.5	30 <sup>+0.4</sup> <sub>-0.2</sub>	200±0.5	120±0.5	0.7 <sup>+0.7</sup> <sub>0</sub>	MAX.190	22	70
58	K3 FF 2380x1200x630x1.00	1	238±0.5	63±0.3	188±0.5	120±0.5	1.0±0.3	MAX.175	44	116
59	K3 FF 2380x1500x630x1.10	1	238±0.5	63±0.3	188±0.5	150±0.5	1.1 <sup>+0.4</sup> <sub>-0.3</sub>	MAX.175	51	127

# FF SERIES

## (FLAT CABLE SUPPRESSION CORES)

Unit:mm

NO.	FERRICO PART NO.	Fig.	A	B	C	D	E	APPLICABLE CABLE (WIDE)	IMPEDANCE(Ω)	
									TYP.	
									25 MHz	100 MHz
60	K3 FF 2450x1200x500x0.50	1	24.5±0.5	50 <sup>±0</sup> <sub>0.7</sub>	200±0.5	120±0.5	0.5 <sup>±0.6</sup> <sub>0</sub>	MAX.190	42	121
61	K3 FF 2450x2000x500x0.50	1	24.5±0.5	50 <sup>±0</sup> <sub>0.7</sub>	200±0.5	200±0.6	0.5 <sup>±0.6</sup> <sub>0</sub>	MAX.190	60	165
62	K3 FF 2450x200x500x0.70	1	24.5±0.5	50 <sup>±0</sup> <sub>0.7</sub>	200±0.5	200±0.6	0.7 <sup>±0.6</sup> <sub>0</sub>	MAX.190	60	160
63	K3 FF 2500x1200x500x0.80	1	25.0±0.5	50±0.5	21.0±0.5	120±0.5	0.8±0.3	MAX.200	43	117
64	K3 FF 2500x1200x500x1.00	1	25.0±0.5	50±0.3	21.5±0.6	120±0.4	1.0±0.3	MAX.205	42	122
65	K3 FF 2500x1200x300x0.80	1	25.0±0.5	3.0±0.3	21.0±0.5	120±0.5	0.8±0.3	MAX.200	36	103
66	K3 FF 2500x1600x7.70x0.90	1	25.0±0.5	7.7±0.3	18.0±0.38	16.0±0.32	0.9±0.2	MAX.17.0	70	158
67	K3 FF 2500x1200x500x1.30	1	25.0±0.5	50±0.3	17.3±0.5	120±0.5	1.3±0.3	MAX.160	37	99
68	K3 FF 25.50x1000x500x1.50	5	25.5±0.5	50±0.3	22.0±0.3	100±0.4	1.5±0.3	MAX.21.0	30	88
69	K3 FF 2600x900x500x1.20	1	26.0±0.5	50±0.4	22.0±0.5	90±0.5	1.2±0.4	MAX.21.0	30	89
70	K3 FF 26.50x2600x500x0.50	1	26.5±0.5	50 <sup>±0</sup> <sub>0.7</sub>	22.0±0.5	260±0.5	0.5 <sup>±0.6</sup> <sub>0</sub>	MAX.21.0	74	193
71	K3 FF 27.00x800x6.50x1.30	1	27.0±0.5	6.5±0.4	22.0±0.5	8.0±0.4	1.3 <sup>0.4</sup> <sub>0.3</sub>	MAX.21.0	33	93
72	K3 FF 27.40x1500x3.50x1.30	1	27.4±0.5	3.5±0.4	24.6±0.5	15.0±0.5	1.3 <sup>0.5</sup> <sub>0.2</sub>	MAX.23.5	32	95
73	K3 FF 2800x900x3.50x0.80	4	28.0±0.5	3.5±0.4	24.0±0.5	9.0±0.4	0.8±0.35	MAX.23.0	32	98
74	K3 FF 2800x1200x400x1.00	1	28.0±0.5	4.0±0.4	24.0±0.5	12.0±0.5	1.0±0.3	MAX.23.0	35	103
75	K3 FF 2800x600x400x1.50	1	28.0±0.5	4.0±0.4	24.0±0.5	6.0±0.4	1.5±0.3	MAX.23.0	21	69
76	K3 FF 2800x600x500x0.80	1	28.0±0.5	5.0±0.4	24.0±0.5	6.0±0.4	0.8 <sup>0.4</sup> <sub>0.2</sub>	MAX.23.0	26	81
77	K3 FF 2800x800x6.50x1.00	1	28.0±0.5	6.5±0.5	23.5±0.5	8.0±0.5	1.0 <sup>0.4</sup> <sub>0.3</sub>	MAX.22.5	34	95
78	K3 FF 2800x14.60x7.70x1.40	2	28.0±0.5	7.7±0.5	23.0±0.5	14.6±0.6	1.4±0.4	MAX.22.0	48	121
79	K3 FF 2800x7.00x7.70x1.50	3	28.0±0.5	7.7±0.5	23.0±0.5	7.0±0.4	1.5±0.4	MAX.22.0	29	82
80	K3 FF 28.50x1200x500x1.00	4	28.5±0.5	50 <sup>±0.6</sup> <sub>0.4</sub>	24.0±0.5	120±0.5	1.0 <sup>0.4</sup> <sub>0.3</sub>	MAX.23.0	41	113
81	K3 FF 28.50x1800x6.50x1.00	1	28.5±1.0	6.5±0.5	23.5±0.7	18.0±0.7	1.0±0.3	MAX.22.5	61	160
82	K3 FF 28.60x1500x4.55x1.50	1	28.6±0.4	4.55±0.3	25.0±0.4	15.0±0.4	1.5±0.3	MAX.24.0	36	104
83	K3 FF 28.60x3100x7.70x1.70	1	28.6±1.0	7.7±0.5	23.5±0.8	31.0±1.0	1.7±0.4	MAX.22.5	90	207
84	K3 FF 2900x1000x800x1.85	1	29.0±1.0	8.0±0.3	21.5±0.5	10.0±0.3	1.85±0.3	MAX.20.5	37	95
85	K3 FF 2900x1000x800x2.00	1	29.0±0.5	8.0±0.4	22.0±0.5	10.0±0.5	2.0±0.3	MAX.21.0	35	92
86	K3 FF 31.00x1200x300x0.50	1	31.0±0.7	3.0±0.3	27.0±0.8	12.0±0.5	0.5 <sup>0.7</sup> <sub>0</sub>	MAX.26.0	35	104
87	K3 FF 31.00x1200x500x0.50	1	31.0±0.7	50 <sup>±0</sup> <sub>0.7</sub>	27.0 <sup>±0.9</sup> <sub>0.7</sub>	12.0±0.5	0.5 <sup>±0.7</sup> <sub>0</sub>	MAX.26.0	43	122
88	K3 FF 31.00x1200x500x1.00	1	31.0±0.7	50 <sup>±0</sup> <sub>0.7</sub>	27.0 <sup>±0.9</sup> <sub>0.7</sub>	12.0±0.5	1.0±0.3	MAX.26.0	38	112
89	K3 FF 32.00x800x500x0.80	1	32.0±0.8	5.0±0.3	28.0±0.6	8.0±0.3	0.8±0.3	MAX.27.0	33	97

# FF SERIES

## (FLAT CABLE SUPPRESSION CORES)

Unit:mm

NO.	FERRICO PART NO.	Fig	A	B	C	D	E	APPLICABLE CABLE (WIDE)	IMPEDANCE(Ω)	
									TYP.	
									25 MHz	100 MHz
90	K3 FF 3200x970x775x150	1	320±05	775±05	278±05	97±05	15±04	MAX.268	35	98
91	K3 FF 3200x1200x350x070	4	320±1.0	35±0.4	280±0.8	120±0.5	07±0.4	MAX.27.0	40	116
92	K3 FF 3200x1200x350x1.0	4	320±1.0	35±0.4	280±0.8	120±0.5	1.0±0.3	MAX.27.0	33	95
93	K3 FF 3200x950x650x250	1	320±1.0	65±0.5	280±0.7	95±0.5	25±0.5	MAX.27.0	26	82
94	K3 FF 3200x3000x700x1.00	4	320±0.6	7.0±0.3	260±0.5	300±0.6	1.0±0.3	MAX.25.0	100	260
95	K3 FF 3320x1500x770x150	1	332±1.0	77± <sup>06</sup> / <sub>01</sub>	270±0.8	150±0.6	15±0.2	MAX.26.0	49	125
96	K3 FF 3340x1200x660x1.40	4	334±1.0	66±0.4	284±0.8	120±0.5	14±0.3	MAX.27.4	37	104
97	K3 FF 3350x1200x650x1.00	1	335±1.0	65±0.4	270±0.8	120±0.5	1.0±0.3	MAX.26.0	44	121
98	K3 FF 3350x800x650x1.30	1	335±1.0	65±0.4	270±0.8	80±0.5	1.3±0.3	MAX.26.0	30	91
99	K3 FF 3350x1200x650x1.30	1	335±1.0	65±0.4	270±0.8	120±0.5	1.3±0.3	MAX.26.0	40	112
100	K3 FF 3350x2000x650x1.30	1	335±1.0	65±0.4	270±0.8	200±0.5	1.3±0.3	MAX.26.0	56	147
101	K3 FF 3350x1200x650x1.30	1	335±1.0	65±0.4	280±0.8	120±0.5	1.3±0.3	MAX.27.0	41	113
102	K3 FF 3350x2000x650x1.30	1	335±1.0	65±0.4	290±0.8	200±0.5	1.3±0.3	MAX.28.0	57	153
103	K3 FF 3500x2500x700x1.00	1	350±1.0	7.0±0.5	290±0.8	250±0.8	1.0± <sup>04</sup> / <sub>03</sub>	MAX.28.0	85	228
104	K3 FF 3500x1460x770x1.40	1	350±1.0	77±0.5	300±0.8	146±0.6	14±0.4	MAX.29.0	46	121
105	K3 FF 3600x1200x350x080	4	360±1.0	35±0.2	320±0.8	120±0.5	08±0.3	MAX.31.0	36	101
106	K3 FF 3701x1346x450x051	1	3701±1.0	45±0.5	330±0.8	1346±0.8	051± <sup>05</sup> / <sub>02</sub>	MAX.32.0	48	134
107	K3 FF 3850x2540x1200x180	4	385±1.0	12.0±0.5	268±0.8	254±0.8	1.8±0.35	MAX.25.5	97	216
108	K3 FF 3885x2860x2600x1295	1	3885±0.75	260±0.6	265±0.75	286±0.7	1295±0.25	MAX.25.0	100	157
109	K3 FF 3900x1200x400x080	4	390±0.8	4.0±0.5	350±0.8	120±0.5	08±0.5	MAX.34.0	40	122
110	K3 FF 3900x1200x400x1.00	4	390±0.8	4.0±0.5	350±0.8	120±0.5	1.0±0.3	MAX.34.0	37	102
111	K3 FF 4000x1200x650x1.00	1	400±1.0	65±0.5	350±0.8	120±0.5	1.0±0.3	MAX.34.0	43	122
112	K3 FF 4000x1000x650x1.30	1	400±1.0	65±0.5	350±0.8	100±0.5	1.3±0.3	MAX.34.0	33	98
113	K3 FF 4000x1200x650x1.30	1	400±1.0	65±0.5	350±0.8	120±0.5	1.3±0.3	MAX.34.0	39	112
114	K3 FF 4000x2000x650x1.30	1	400±1.0	65±0.5	350±0.8	200±0.5	1.3±0.3	MAX.34.0	58	155
115	K3 FF 4000x1200x870x350	1	400±1.0	87±0.5	350±0.8	120±0.5	35±0.4	MAX.34.0	27	78
116	K3 FF 4000x1250x1000x200	4	400±1.0	10.0±0.5	323±0.8	125±0.5	20±0.4	MAX.31.3	44	112
117	K3 FF 4100x1200x650x1.30	1	410±1.0	65±0.6	360±0.7	120±0.5	1.3±0.3	MAX.35.0	40	118
118	K3 FF 4510x2860x1250x150	4	451±0.9	125±0.25	344±0.64	286±0.64	15±0.4	MAX.33.5	112	285



# FF SERIES (FLAT CABLE SUPPRESSION CORES)

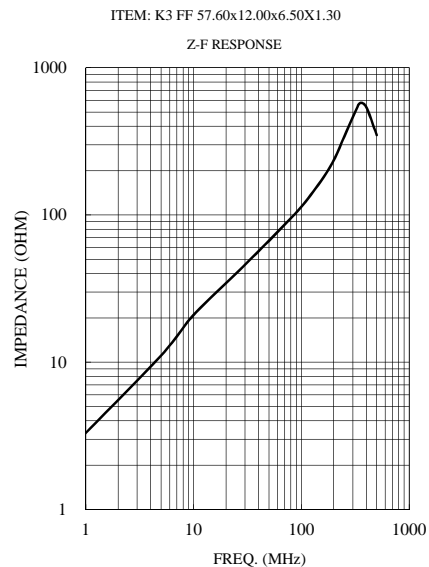
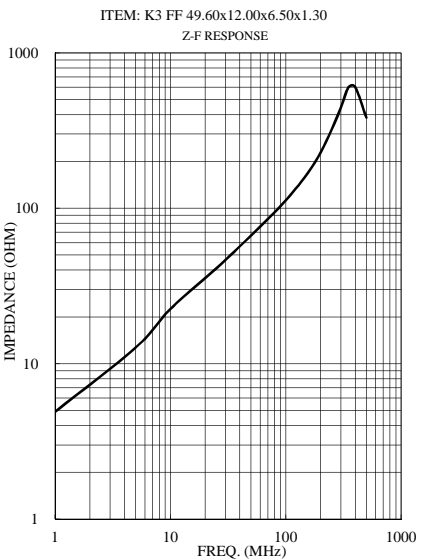
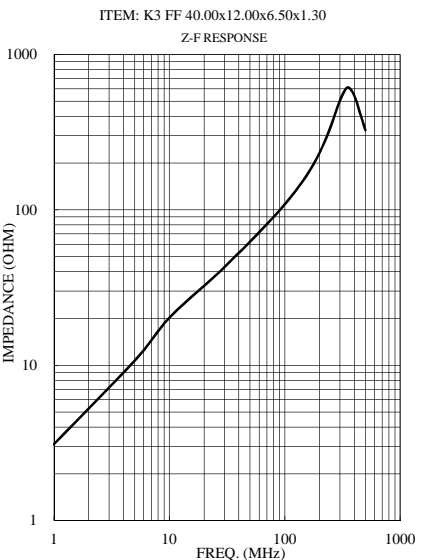
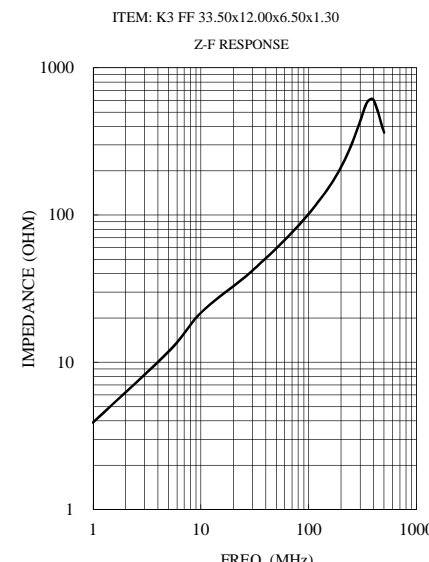
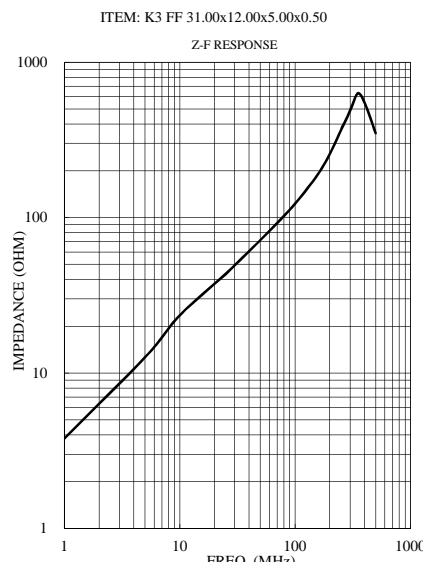
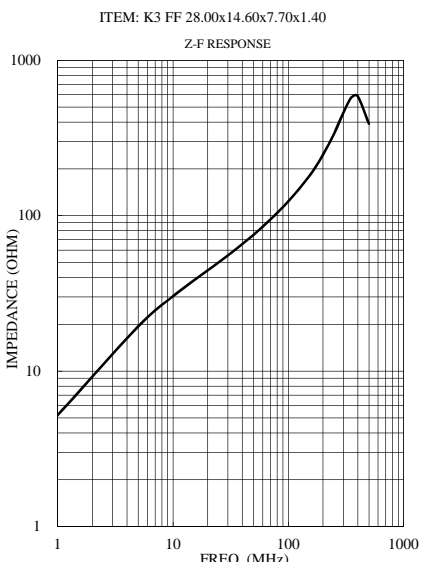
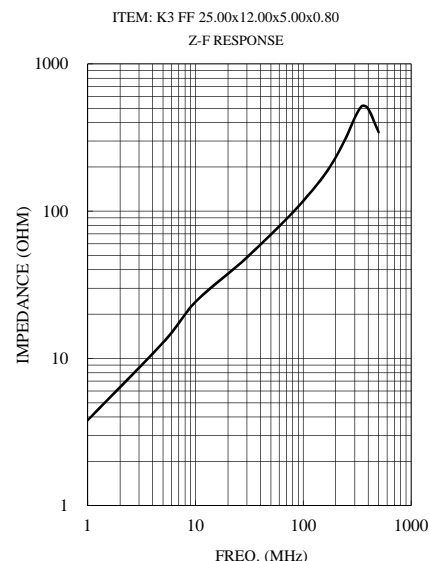
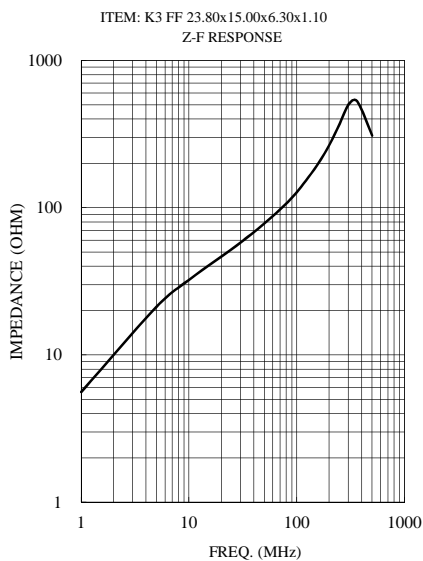
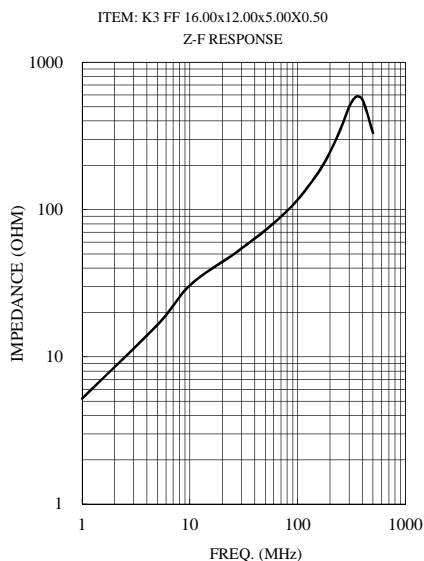

# FFS SERIES

## (FLAT CABLE SUPPRESSION CORES)

### 1. ORDERING CODE

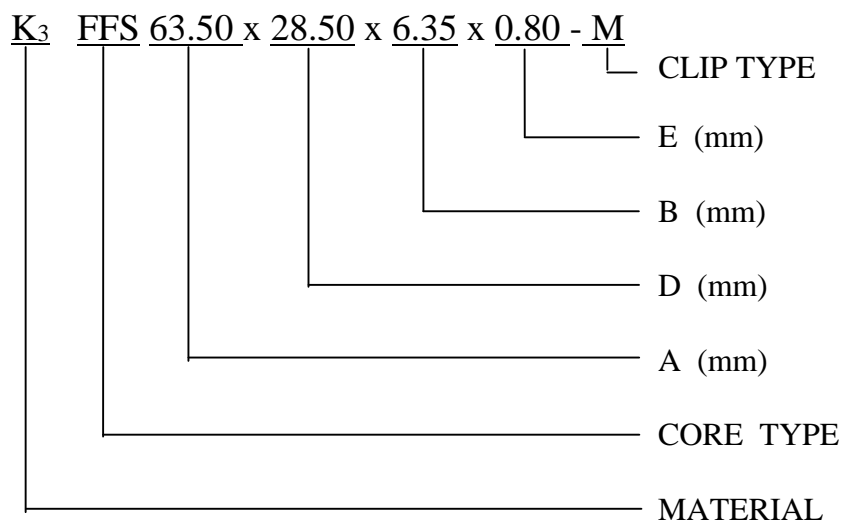

### 2. SHAPES

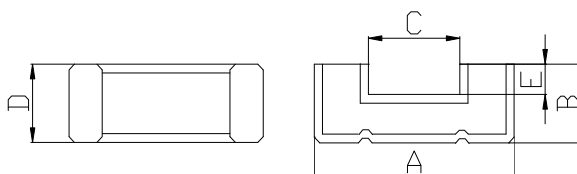

### 3. DIMENSIONS

Unit: mm

NO.	FERRICO PART NO.	A	B	C	D	E	IMPEDANCE(Ω) (TYP.)	
							25MHz	100MHz
1	K3 FFS 38.00x12.70x6.35x0.84 -M	38.0 ±0.76	6.35±0.25	26.7± 0.76	12.7±0.5	0.84±0.25	54	130
2	K3 FFS 38.00x25.40x6.35x0.84-M	38.0 ±0.76	6.35±0.25	26.7± 0.76	25.4±0.7	0.84±0.25	91	167
3	K3 FFS 45.00x28.50x6.35x0.80-M	45.0±1.0	6.35±0.25	34.4±0.7	28.6±0.7	0.8±0.2	93	240
4	K3 FFS 63.50x15.00x6.35x0.80-M	63.5±1.5	6.35±0.25	52.0±1.2	15.0±0.4	0.8±0.2	64	176
5	K3 FFS 63.50x28.50x6.35x0.80-M	63.5±1.5	6.35±0.25	52.0±1.2	28.5±0.7	0.8 <sup>±0.30</sup> <sub>±0.20</sub>	77	194
6	K3 FFS 76.20x15.00x6.35x0.80-M	76.2±1.5	6.35±0.4	65.3±1.3	15.0±0.64	0.8±0.25	45	125
7	K3 FFS 76.20x28.50x6.70x0.80-M	76.2±1.5	6.7±0.4	65.3±1.3	28.6±0.7	0.8 <sup>±0.30</sup> <sub>±0.20</sub>	63	164
8	K3 FFS 88.90x28.50x6.50x0.80-M	88.9±1.8	6.5±0.3	78.2±1.5	28.6±0.8	0.84±0.3	100	290

REMARK : OTHER SIZES AND MATERIAL ARE AVAILABLE UPON REQUEST

# FFS SERIES

## (FLAT CABLE SUPPRESSION CORES)

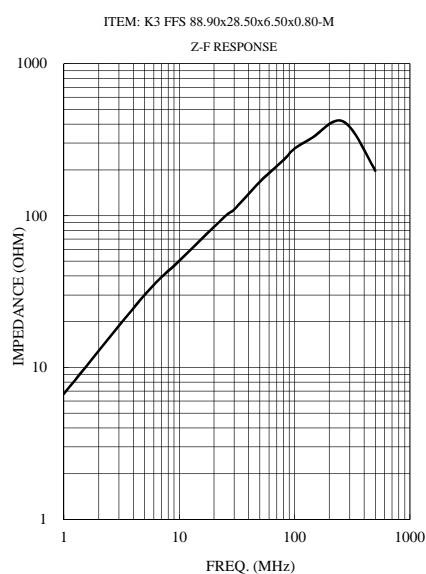
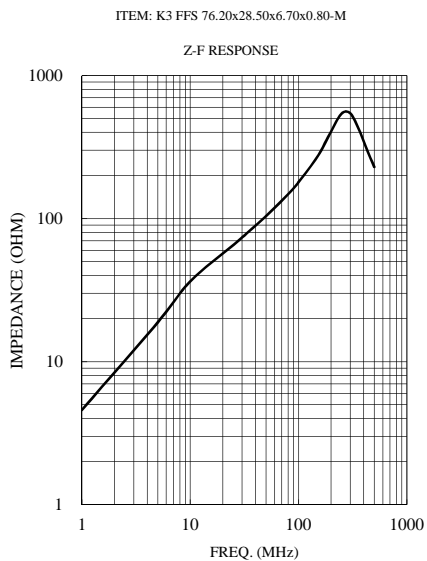
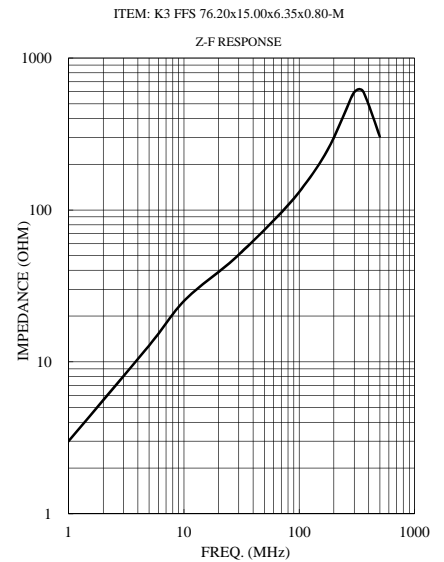
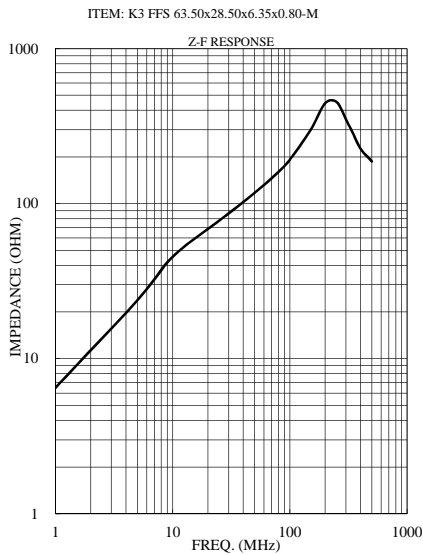
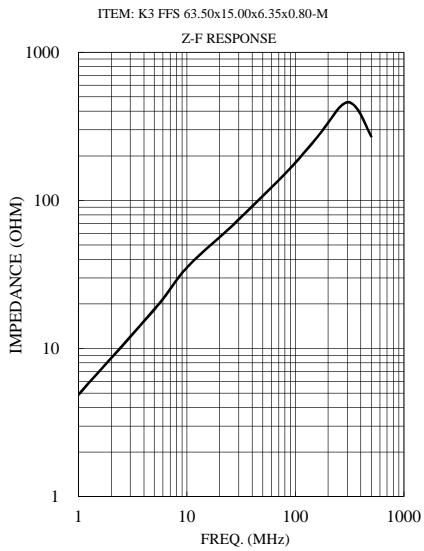
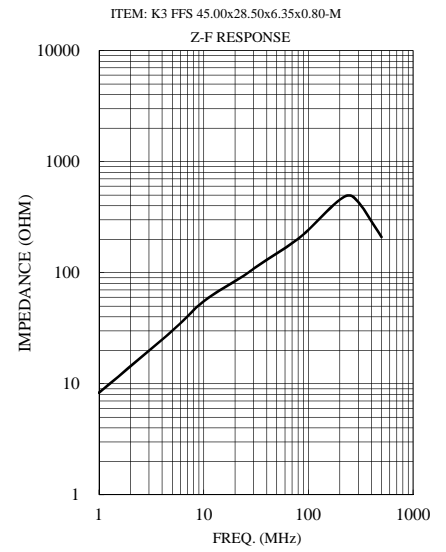
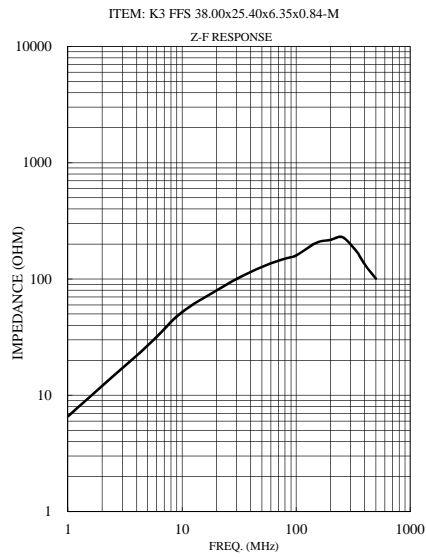
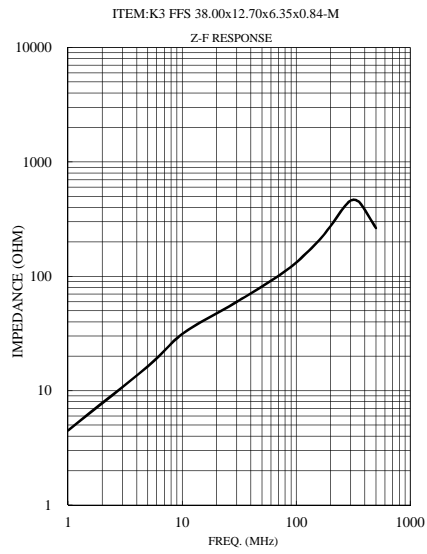

# NF SERIES

(EMI SUPPRESSION CORES WITH PLASTIC CASE)

## 1. ORDERING CODE

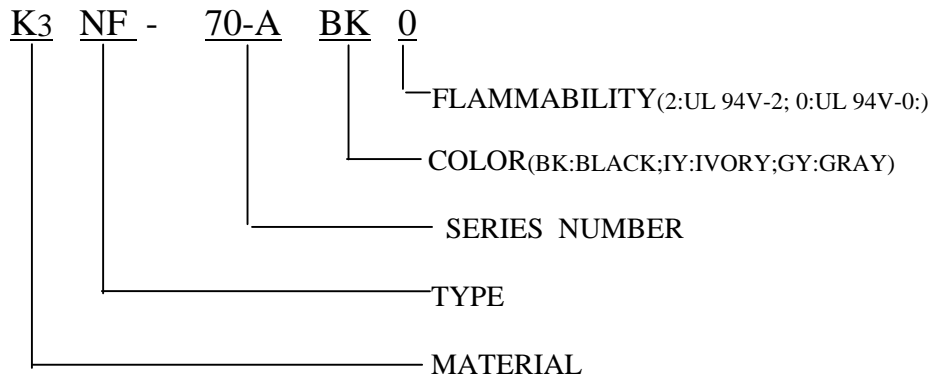

## 2. SHAPES

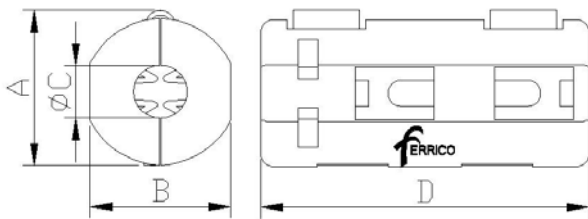

Fig.1

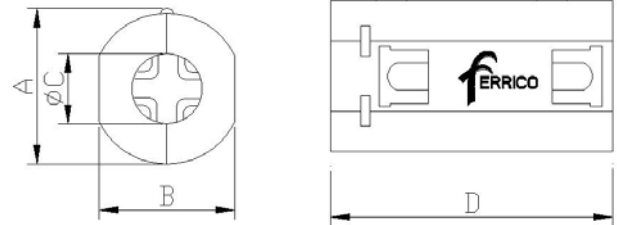

Fig.2

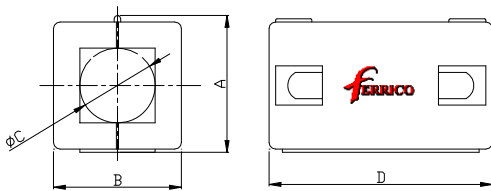

Fig.3

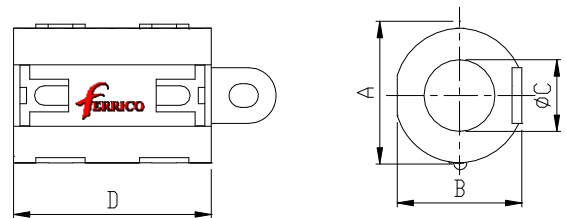

Fig.4

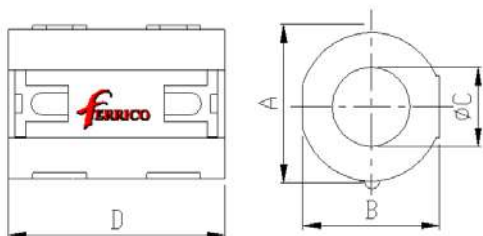

Fig.5

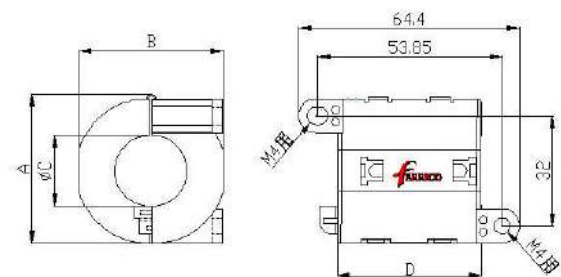

Fig.6

# NF SERIES



## (EMI SUPPRESSION CORES WITH PLASTIC CASE)

### 3.DIMENSIONS

Unit:mm

NO.	FERRICO PART NO.	Fig.	A	B	C	D	CABLE DIAMETER	IMPEDANCE( $\Omega$ )	
								TYP.	
								25MHz	100 MHz
1	K3 NF-30-A(N)BK0	1	12.0 $\pm$ 1.0	11.5 $\pm$ 1.0	4.0 $\pm$ 1.0	25.0 $\pm$ 1.0	MAX. $\Phi$ 3.5	66	142
2	K3 NF-55(N)BK0	2	14.5 $\pm$ 1.0	13.5 $\pm$ 1.0	5.5 $\pm$ 1.0	29.5 $\pm$ 1.0	MAX. $\Phi$ 5.0	64	146
3	K3 NF-55-B(N)BK0	2	14.5 $\pm$ 1.0	13.5 $\pm$ 1.0	5.5 $\pm$ 1.0	43.0 $\pm$ 1.0	MAX. $\Phi$ 5.0	125	270
4	K3 NF-60-A(N)BK0	2	19.8 $\pm$ 1.0	18.0 $\pm$ 1.0	6.0 $\pm$ 1.0	37.0 $\pm$ 1.0	MAX. $\Phi$ 5.5	150	260
5	K3 NF-65-A(N)BK0	3	20.5 $\pm$ 1.0	20.0 $\pm$ 1.0	6.5 $\pm$ 1.0	32.5 $\pm$ 1.0	MAX. $\Phi$ 6.2	123	293
6	K3 NF-70-ABK0	1	16.0 $\pm$ 1.0	14.0 $\pm$ 1.0	7.2 $\pm$ 1.0	24.0 $\pm$ 1.0	MAX. $\Phi$ 6.7	55	100
7	K3 NF-72(N)BK0	1	16.0 $\pm$ 1.0	14.0 $\pm$ 1.0	7.2 $\pm$ 1.0	31.5 $\pm$ 1.0	MAX. $\Phi$ 6.7	60	133
8	K3 NF-75BK0	2	19.8 $\pm$ 1.0	18.0 $\pm$ 1.0	9.0 $\pm$ 1.0	37.0 $\pm$ 1.0	MAX. $\Phi$ 8.8	105	175
9	K3 NF-100-ABK0	3	25.5 $\pm$ 1.0	23.5 $\pm$ 1.0	10.0 $\pm$ 1.0	32.5 $\pm$ 1.0	MAX. $\Phi$ 9.7	129	207
10	K3 NF-110-A(N)BK0	2	20.5 $\pm$ 1.0	21.0 $\pm$ 1.0	11.0 $\pm$ 1.0	36.5 $\pm$ 1.0	MAX. $\Phi$ 10.5	76	140
11	K3 NF-110-B(N)BK0	4	20.5 $\pm$ 1.0	21.0 $\pm$ 1.0	11.0 $\pm$ 1.0	30.5 $\pm$ 1.0	MAX. $\Phi$ 10.8	76	140
12	K3 NF-110-C(N)BK0	5	20.5 $\pm$ 1.0	21.0 $\pm$ 1.0	11.0 $\pm$ 1.0	30.5 $\pm$ 1.0	MAX. $\Phi$ 10.8	76	140
13	K3 NF-125BK0	2	30.0 $\pm$ 1.0	29.0 $\pm$ 1.0	13.0 $\pm$ 1.0	39.0 $\pm$ 1.0	MAX. $\Phi$ 12.5	120	205
14	K3 NF-130-A(N)BK0	3	31.5 $\pm$ 1.0	30.5 $\pm$ 1.0	13.0 $\pm$ 1.0	32.5 $\pm$ 1.0	MAX. $\Phi$ 12.7	122	236
15	K3 NF-190GY0	2	40.0 $\pm$ 1.0	40.0 $\pm$ 1.0	19.0 $\pm$ 1.0	41.0 $\pm$ 1.0	MAX. $\Phi$ 18.5	123	206
16	K3 NF-205GY0	2	42.5 $\pm$ 1.0	42.0 $\pm$ 1.0	20.5 $\pm$ 1.0	42.0 $\pm$ 1.0	MAX. $\Phi$ 20.0	137	215
17	F6 NF-205BGY0	6	42.5 $\pm$ 1.0	42.0 $\pm$ 1.0	20.5 $\pm$ 1.0	42.0 $\pm$ 1.0	MAX. $\Phi$ 20.0	160	220

REMARK : 1. COMBINATION CASE & 2 FERRITE PARTS

2. MATERIAL IS AVAILABLE UPON REQUEST

3.CASE COLOR (BLACK, IVORY, GRAY) IS AVAILABLE UPON REQUEST

# NF SERIES

## (EMI SUPPRESSION CORES WITH PLASTIC CASE)

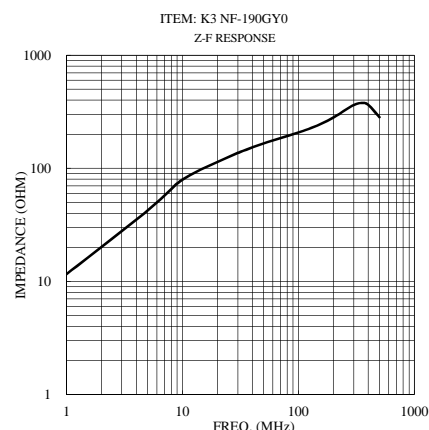
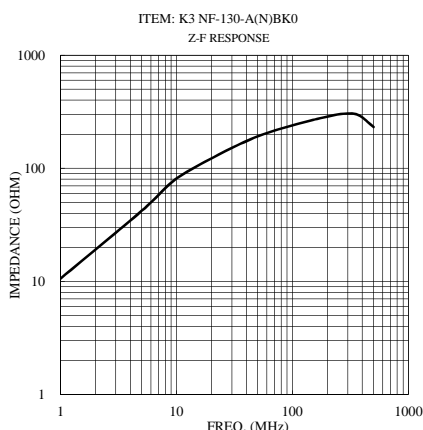
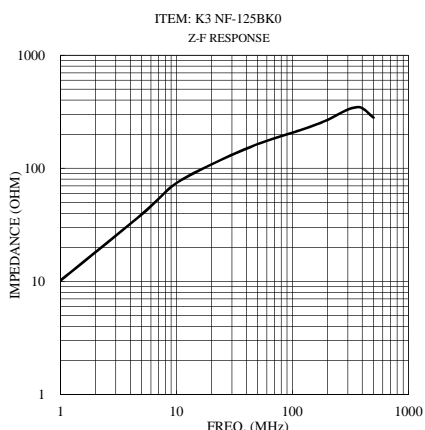
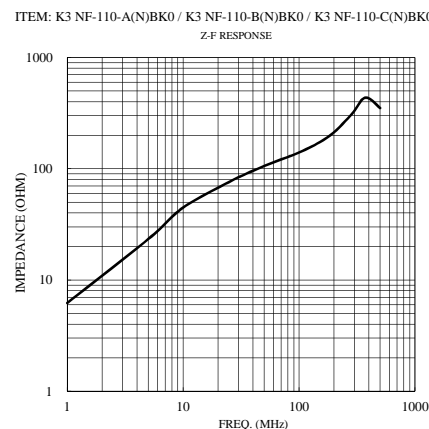
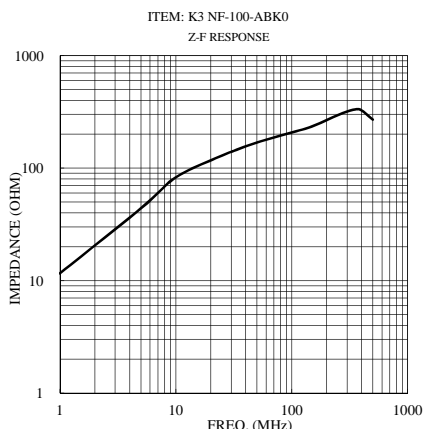
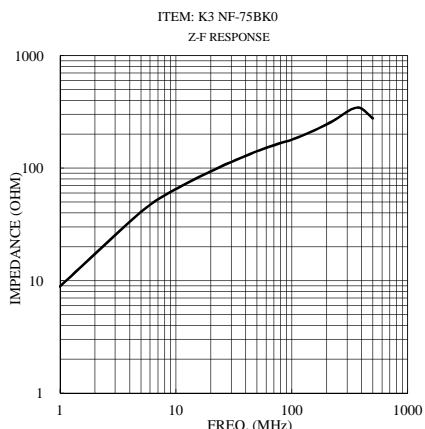
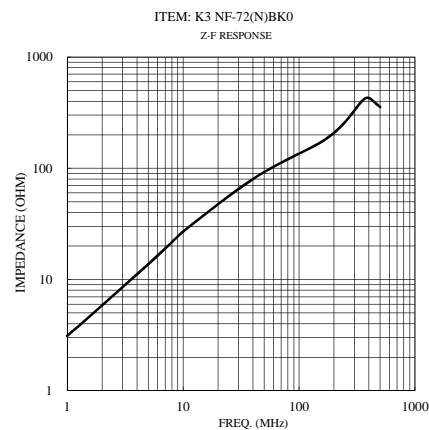
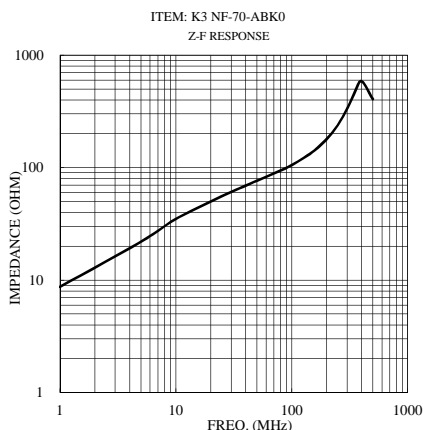
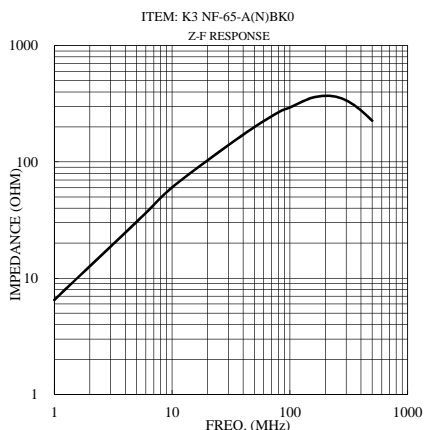
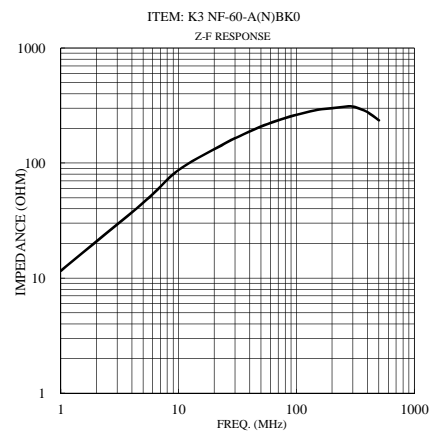
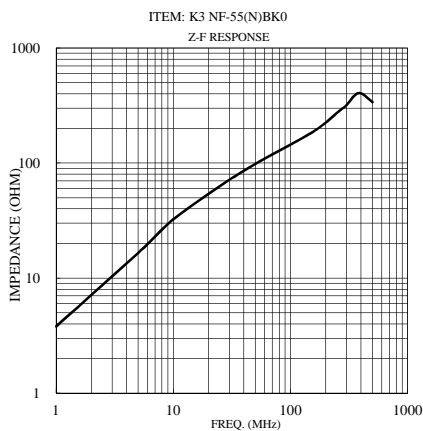
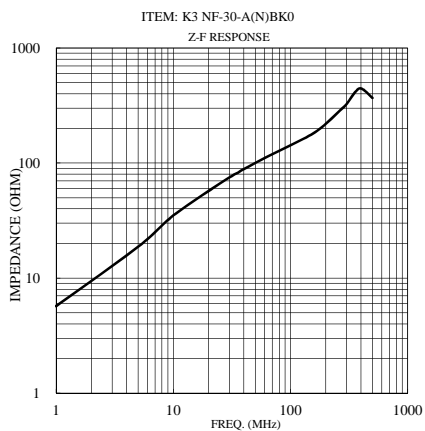

# NFR SERIES

(EMI SUPPRESSION CORES WITH PLASTIC CASE)

## 1. ORDERING CODE

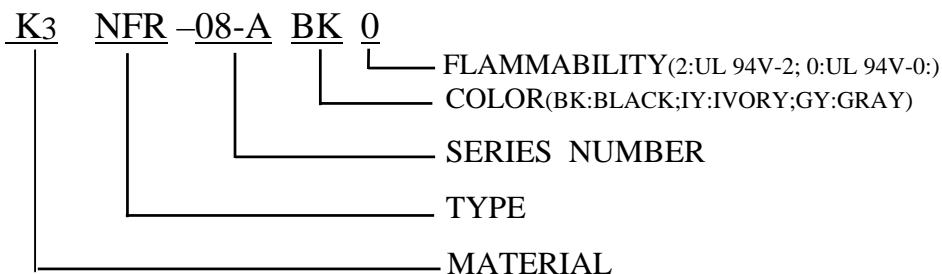

## 2. SHAPES

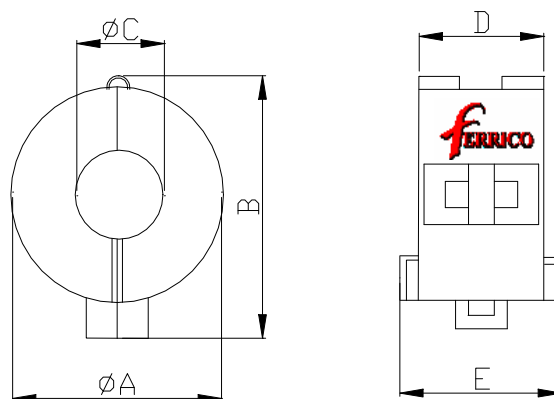

## 3. DIMENSIONS

Unit:mm

NO.	FERRICO PART NO.	ΦA	B	ΦC	D	E	CABLE DIAMETER	IMPEDANCE(Ω) TYP.	
								25 MHz	100 MHz
1	K3 NFR-08-ABK0	19.5±1.0	24.0±1.0	8.0±1.0	17.0±1.0	22.5±1.0	MAX. Φ 7.5	57	117
2	K3 NFR-08BBK0	19.6±1.0	24.0±1.0	8.0±1.0	19.6±1.0	25.6±1.0	MAX. Φ 7.5	72	122
3	K3 NFR-10-ABK0	24.0±1.0	28.0±1.0	10.0±1.0	13.0±1.0	19.0±1.0	MAX. Φ 9.5	46	92
4	K3 NFR-12-ABK0	28.0±1.0	32.0±1.0	12.0±1.0	16.5±1.0	22.5±1.0	MAX. Φ 11.0	67	123
5	K3 NFR-14-ABK0	30.0±1.0	34.0±1.0	14.0±1.0	14.5±1.0	21.0±1.0	MAX. Φ 13.5	44	85

REMARK :1. COMBINATION CASE & 2 FERRITE PARTS

2. MATERIAL IS AVAILABLE UPON REQUEST

3.CASE COLOR (BLACK, IVORY, GRAY) IS AVAILABLE UPON REQUEST

# NFR SERIES

## (EMI SUPPRESSION CORES WITH PLASTIC CASE)

ITEM: K3 NFR-08-ABK0

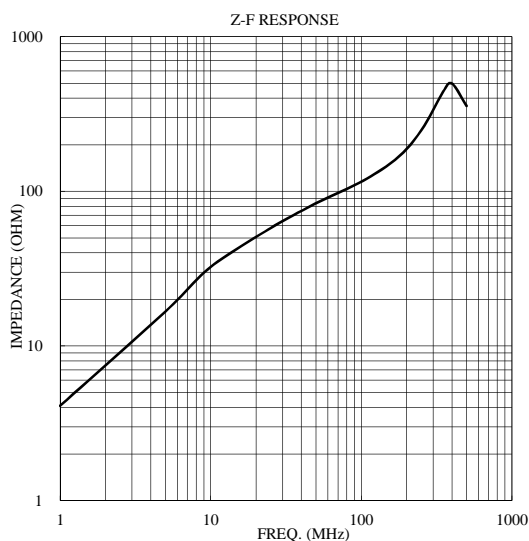

ITEM: K3 NFR-08BBK0

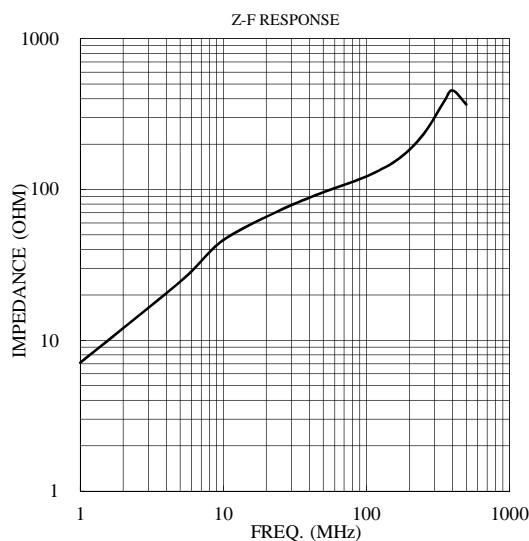

ITEM: K3 NFR-10-ABK0

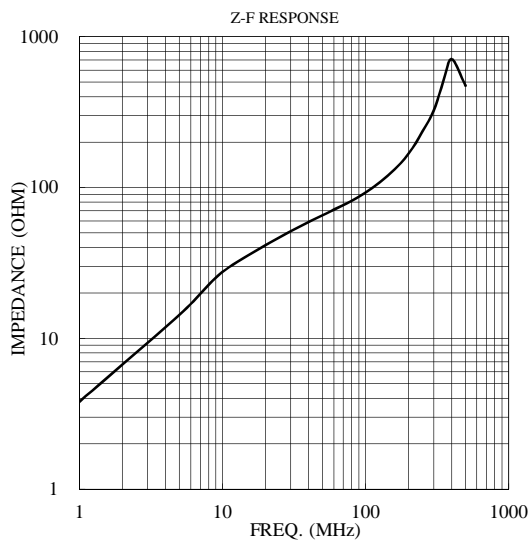

ITEM: K3 NFR-12-ABK0

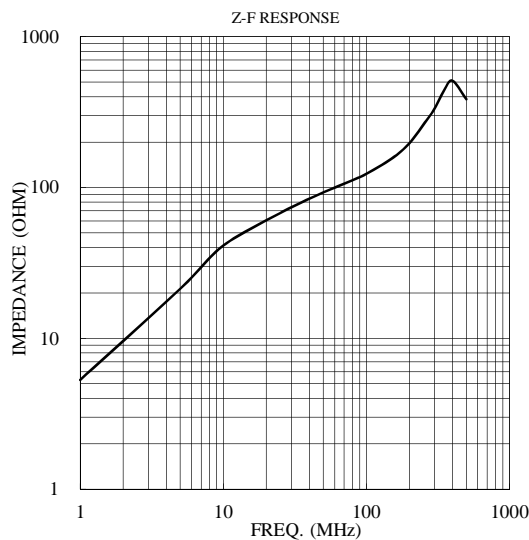

ITEM: K3 NFR-14-ABK0

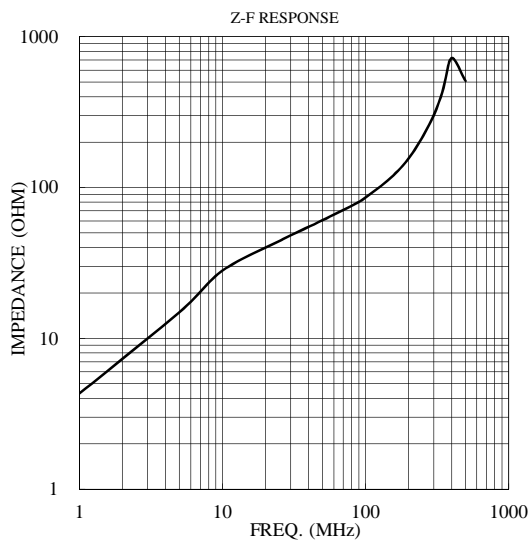

# NFU SERIES

(EMI SUPPRESSION CORES WITH PLASTIC CASE)

## 1. ORDERING CODE

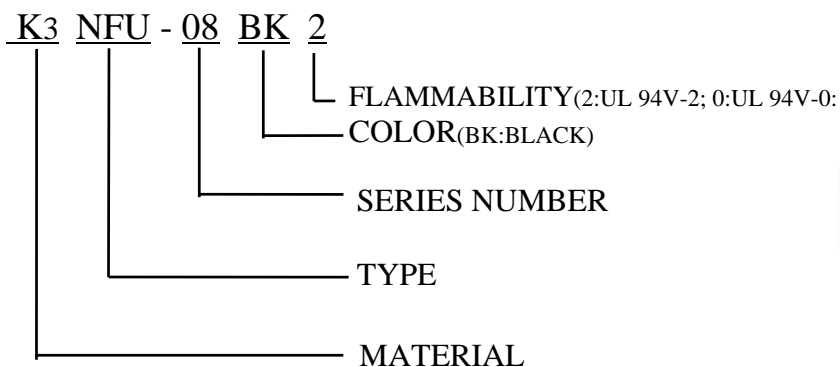

## 2.SHAPES

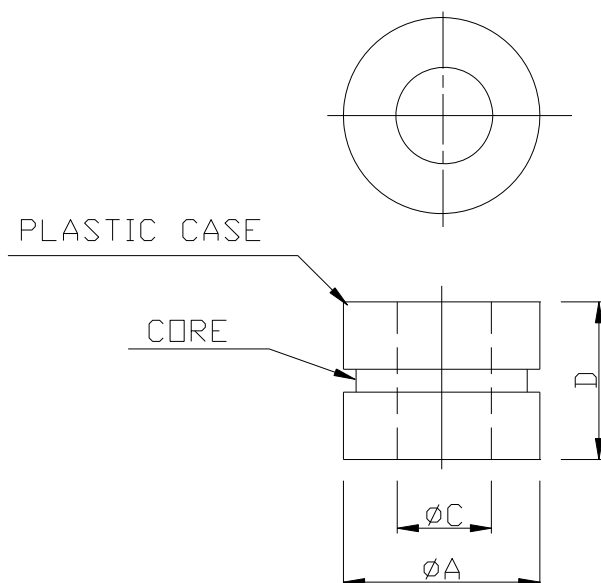

## 3.DIMENSIONS

Unit: mm

NO.	FERRICO PART NO.	$\Phi A$	$\Phi C$	D	CABLE DIAMETER	IMPEDANCE( $\Omega$ ) TYP.	
						25 MHz	100 MHz
1	K3 NFU-08BK2	20.0 $\pm$ 1.0	8.3 $\pm$ 1.0	12.0 $\pm$ 1.0	MAX $\Phi$ 8.0	50	90
2	K3 NFU-13BK2	26.5 $\pm$ 1.0	13.5 $\pm$ 1.0	14.0 $\pm$ 1.0	MAX $\Phi$ 13.0	47	86

REMARK: MATERIAL IS AVAILABLE UPON REQUEST

# NFT SERIES

(EMI SUPPRESSION CORES WITH PLASTIC CASE)

## 1. ORDERING CODE

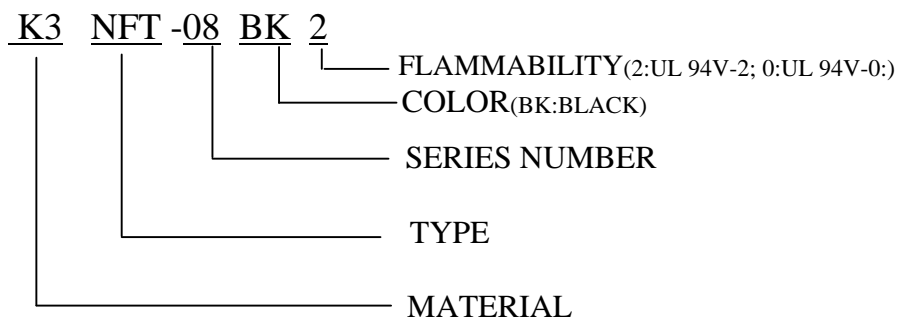

## 2. SHAPES

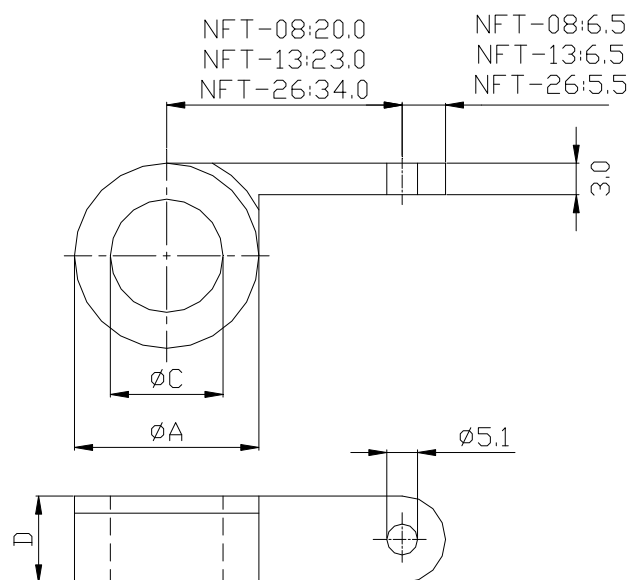

## 3. DIMENSIONS

Unit:mm

NO.	FERRICO PART NO.	$\Phi A$	$\Phi C$	D	CABLE DIAMETER	IMPEDANCE( $\Omega$ ) TYP.	
						25 MHz	100 MHz
1	K3 NFT-08BK2	23.0 $\pm$ 1.0	8.2 $\pm$ 1.0	12.5 $\pm$ 1.0	MAX. $\Phi$ 8.0	52	90
2	K3 NFT-13BK2	29.3 $\pm$ 1.0	13.8 $\pm$ 1.0	13.5 $\pm$ 1.0	MAX. $\Phi$ 13.5	49	88
3	K3 NFT-26BK2	51.5 $\pm$ 1.0	24.5 $\pm$ 1.0	17.0 $\pm$ 1.0	MAX. $\Phi$ 24.0	62	115

REMARK : MATERIAL IS AVAILABLE UPON REQUEST

# NFU、NFT SERIES

## (EMI SUPPRESSION CORES WITH PLASTIC CASE)

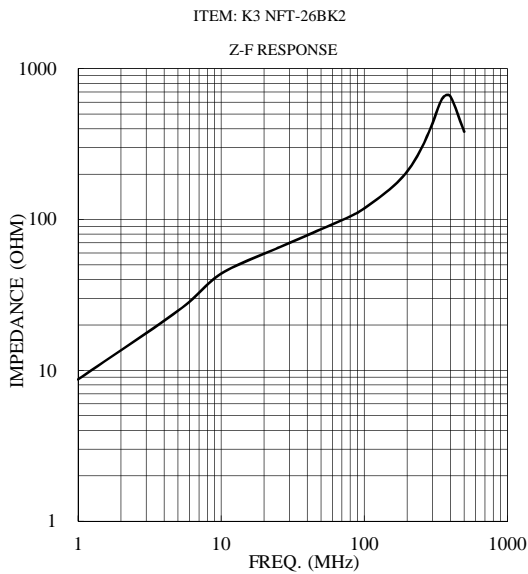
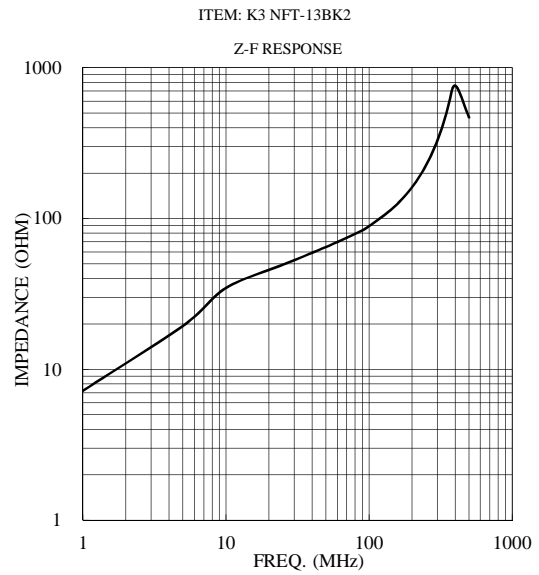
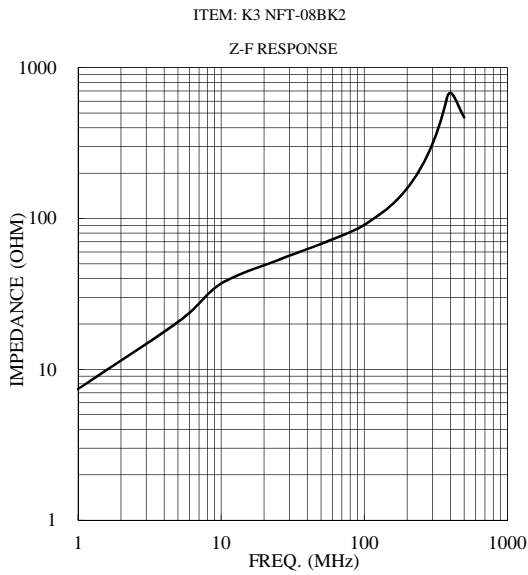
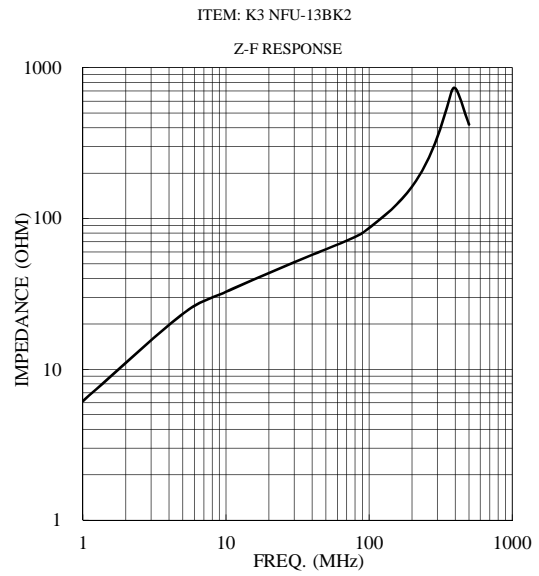
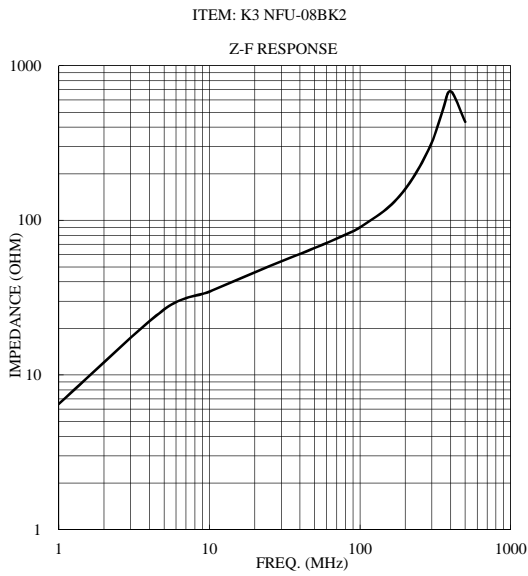



# NFC SERIES

## (EMI SUPPRESSION CORES WITH PLASTIC CASE)

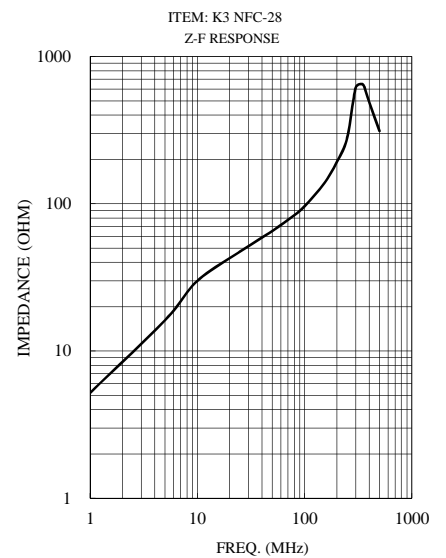
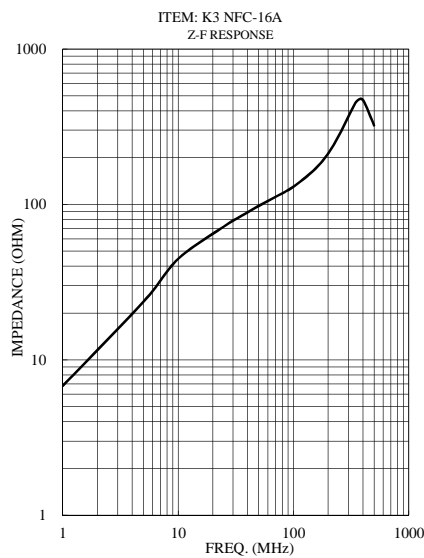
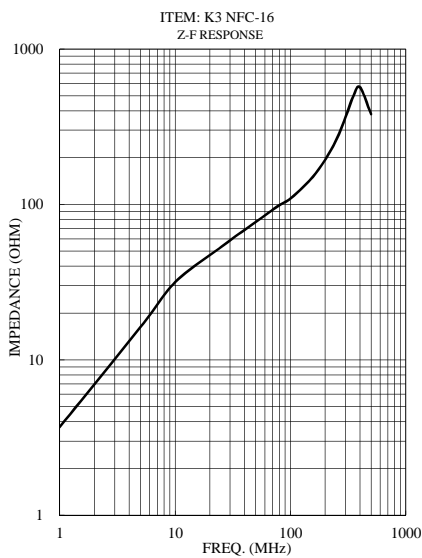
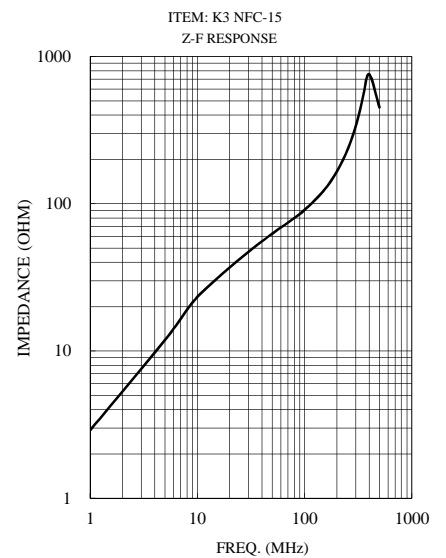
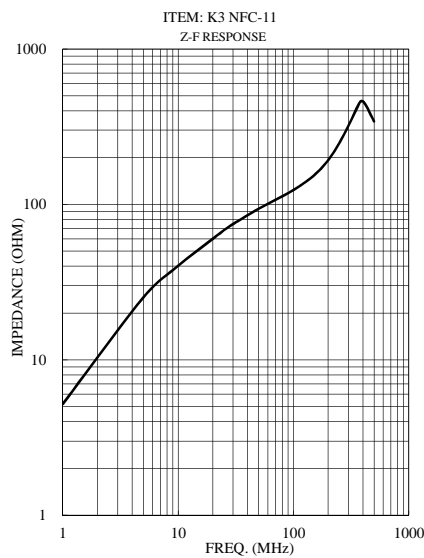
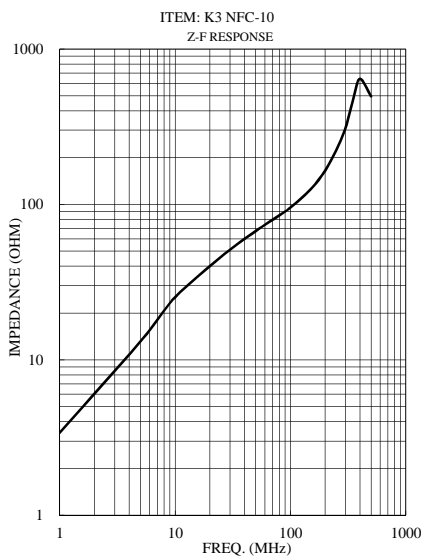
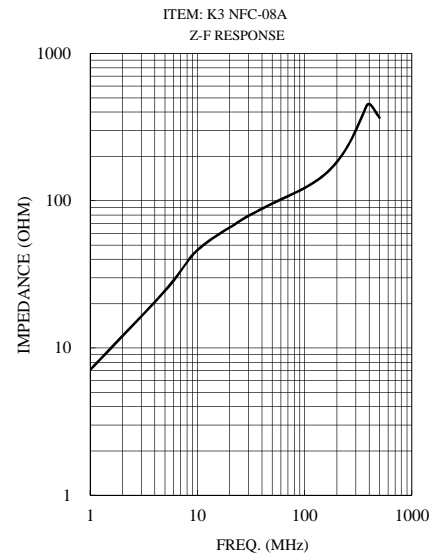
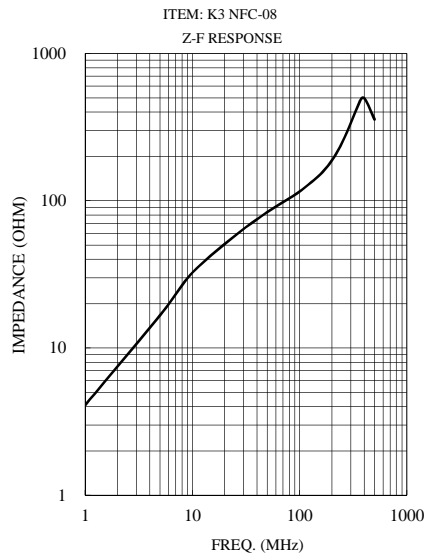
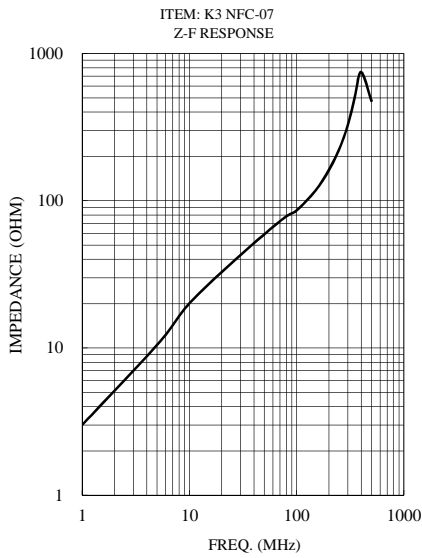

# RH SERIES

## (CYLINDRICAL CORES)

### 1. ORDERING CODE

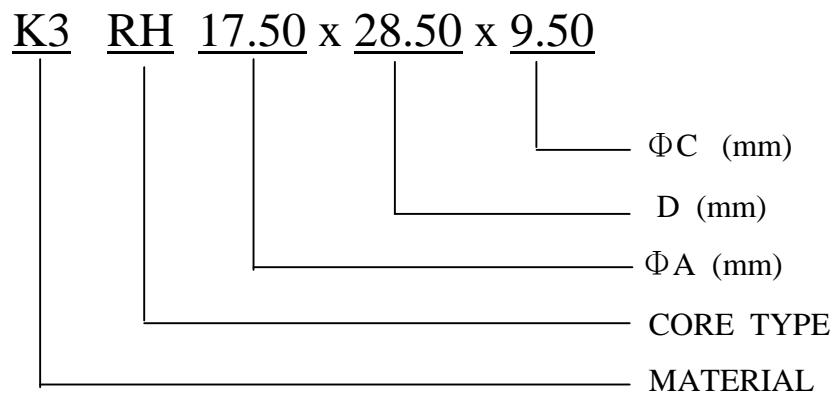

### 2. SHAPES & DIMENSIONS

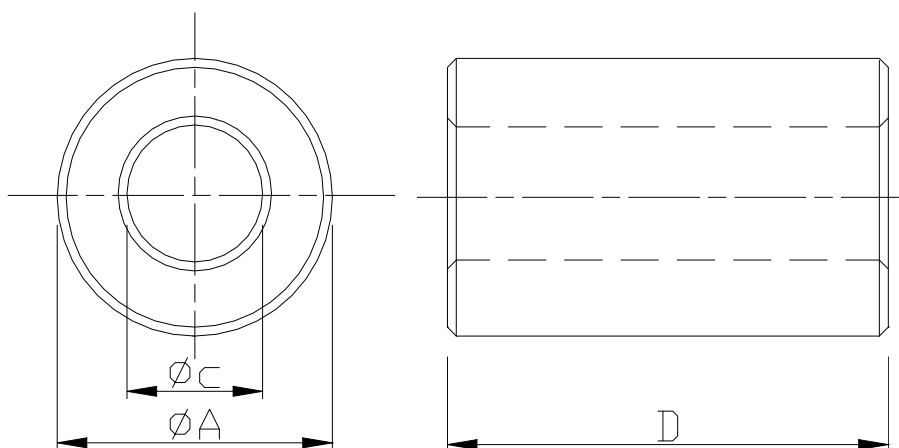

# RH SERIES

## (CYLINDRICAL CORES)

### 3.DIMENSIONS

Unit: mm

NO.	FERRICO PART NO.	IMPEDANCE( $\Omega$ )		NO.	FERRICO PART NO.	IMPEDANCE( $\Omega$ )	
		TYP.				TYP.	
		25 MHz	100 MHz			25 MHz	100 MHz
1	K3 RH 1.63x2.50x1.15	16	48	32	K3 RH 6.00x10.00x2.00	74	126
2	K3 RH 1.90x4.00x0.76	28	68	33	K3 RH 6.00x6.00x3.00	35	71
3	K3 RH 2.50x4.00x1.00	31	67	34	K3 RH 6.00x10.00x4.00	34	71
4	K3 RH 2.50x5.00x0.80	41	59	35	K3 RH 6.35x15.80x3.18	79	123
5	K3 RH 2.54x6.00x1.49	28	66	36	K3 RH 6.40x9.50x3.20	51	93
6	K3 RH 3.00x3.00x1.50	18	37	37	K3 RH 6.40x16.00x3.20	80	127
7	K3 RH 3.00x4.00x2.00	20	54	38	K3 RH 6.40x25.00x3.20	114	171
8	K3 RH 3.50x3.00x1.30	24	43	39	K3 RH 6.78x7.10x4.00	32	69
9	K3 RH 3.50x3.00x1.80	22	60	40	K3 RH 6.80x25.00x2.00	194	280
10	K3 RH 3.50x4.70x0.76	50	81	41	K3 RH 7.50x8.00x2.60	55	92
11	K3 RH 3.50x4.70x0.80	47	92	42	K3 RH 7.80x10.00x3.20	54	94
12	K3 RH 3.50x9.00x0.80	88	127	43	K3 RH 7.80x12.50x4.00	61	99
13	K3 RH 3.50x12.00x0.80	112	150	44	K3 RH 7.80x18.00x4.00	85	128
14	K3 RH 3.50x6.00x1.00	50	83	45	K3 RH 8.00x10.00x3.60	61	102
15	K3 RH 3.50x3.50x1.20	26	65	46	K3 RH 8.00x20.00x3.60	111	157
16	K3 RH 3.50x6.00x1.20	47	80	47	K3 RH 8.00x10.00x4.00	52	90
17	K3 RH 3.50x4.00x1.30	34	67	48	K3 RH 8.00x20.00x4.00	91	148
18	K3 RH 3.50x6.00x1.30	44	78	49	K3 RH 8.00x12.00x4.80	45	90
19	K3 RH 3.50x6.00x1.50	40	63	50	K3 RH 8.00x12.00x5.00	43	86
20	K3 RH 3.50x10.00x1.30	69	120	51	K3 RH 8.50x12.00x5.00	46	90
21	K3 RH 4.00x5.00x2.00	30	67	52	K3 RH 9.00x9.00x5.00	41	81
22	K3 RH 4.00x10.00x2.00	48	73	53	K3 RH 9.00x24.50x5.00	102	163
23	K3 RH 4.00x10.00x2.15	43	69	54	K3 RH 9.30x9.50x5.20	49	90
24	K3 RH 4.50x5.00x1.60	42	80	55	K3 RH 9.50x10.00x5.00	49	85
25	K3 RH 4.50x18.00x2.40	75	108	<b>TOLERANCE IN GENERAL</b> Under 6.0 $\pm 0.3$ Under 18.0~6.0 $\pm 0.5$ Under 24.0~18.0 $\pm 0.6$ Under 30.0~24.0 $\pm 0.8$ Under 40.0~30.0 $\pm 1.5$			
26	K3 RH 4.80x4.80x2.40	25	42				
27	K3 RH 5.00x5.00x2.30	33	68				
28	K3 RH 5.00x6.00x3.00	28	65				
29	K3 RH 5.50x8.00x2.70	35	53				
30	K3 RH 5.65x9.80x3.00	52	92				
31	K3 RH 5.80x10.00x3.40	41	90				

REMARK : 1.TOLERANCE CAN BE MODIFIED TO FIT SPECIFIED APPLICATION.  
 2. OTHER SIZES AND MATERIAL ARE AVAILABLE UPON REQUES

# RH SERIES (CYLINDRICAL CORES)

Unit: mm

NO.	FERRICO PART NO.	IMPEDANCE( $\Omega$ )		NO.	FERRICO PART NO.	IMPEDANCE( $\Omega$ )	
		TYP.				TYP.	
		25 MHz	100 MHz			25 MHz	100 MHz
56	K3 RH 9.50x16.00x5.00	66	115	87	K3 RH 12.20x25.00x8.40	70	116
57	K3 RH 9.50x19.50x5.00	89	141	88	K3 RH 12.30x25.00x4.90	161	248
58	K3 RH 9.50x9.50x5.20	41	83	89	K3 RH 12.30x25.40x4.95	155	222
59	K3 RH 9.50x10.20x5.20	50	95	90	K3 RH 12.70x15.00x7.90	51	90
60	K3 RH 9.66x10.20x3.80	68	108	91	K3 RH 12.70x12.70x7.90	47	90
61	K3 RH 9.90x15.00x6.35	59	128	92	K3 RH 13.00x20.00x5.10	130	202
62	K3 RH 10.00x10.00x5.00	55	93	93	K3 RH 14.20x15.00x6.35	84	125
63	K3 RH 10.00x14.00x6.00	58	87	94	K3 RH 14.20x28.50x6.35	160	236
64	K3 RH 10.00x14.00x6.50	45	83	95	K3 RH 14.20x15.00x6.60	80	128
65	K3 RH 10.00x20.00x6.50	64	107	96	K3 RH 14.20x28.50x6.60	137	227
66	K3 RH 10.00x10.00x7.00	32	70	97	K3 RH 14.20x15.00x7.00	77	119
67	K3 RH 10.00x17.00x5.00	83	141	98	K3 RH 14.20x28.50x7.00	140	206
68	K3 RH 10.50x20.00x5.50	92	136	99	K3 RH 14.20x28.50x7.25	130	198
69	K3 RH 10.50x14.00x5.60	64	106	100	K3 RH 14.20x28.50x8.00	110	165
70	K3 RH 10.50x20.50x5.60	94	142	101	K3 RH 15.00x35.00x6.10	214	315
71	K3 RH 10.70x20.00x6.40	72	118	102	K3 RH 15.00x28.00x6.80	155	229
72	K3 RH 11.00x18.50x5.00	106	166	103	K3 RH 15.60x19.00x7.00	105	166
73	K3 RH 11.00x20.00x5.00	109	164	104	K3 RH 15.60x28.50x7.00	153	223
74	K3 RH 11.00x15.00x6.75	54	96	105	K3 RH 15.90x50.80x7.90	248	358
75	K3 RH 11.50x35.00x5.00	187	289	106	K3 RH 16.00x16.00x8.00	81	125
76	K3 RH 11.80x14.00x6.00	69	113	107	K3 RH 16.00x28.00x8.00	145	217
77	K3 RH 11.80x15.00x7.30	56	98	108	K3 RH 16.00x17.00x9.00	71	113
78	K3 RH 12.00x28.50x5.60	137	215	109	K3 RH 16.00x28.00x9.00	111	166
79	K3 RH 12.00x25.00x6.00	121	180	110	K3 RH 16.00x28.00x9.50	103	160
80	K3 RH 12.00x20.00x6.50	85	133	<b>TOLERANCE IN GENERAL</b> Under 6.0 $\pm 0.3$ Under 18.0~6.0 $\pm 0.5$ Under 24.0~18.0 $\pm 0.6$ Under 30.0~24.0 $\pm 0.8$ Under 40.0~30.0 $\pm 1.5$			
81	K3 RH 12.00x24.50x7.00	91	161				
82	K3 RH 12.00x15.00x7.30	56	94				
83	K3 RH 12.00x15.00x7.50	51	91				
84	K3 RH 12.00x15.00x8.00	46	82				
85	K3 RH 12.00x15.00x8.50	40	79				
86	K3 RH 12.20x12.20x7.90	43	85				

REMARK : 1.TOLERANCE CAN BE MODIFIED TO FIT SPECIFIED APPLICATION.  
2. OTHER SIZES AND MATERIAL ARE AVAILABLE UPON REQUEST

# RH SERIES (CYLINDRICAL CORES)

Unit: mm

NO.	FERRICO PART NO.	IMPEDANCE( $\Omega$ )		NO.	FERRICO PART NO.	IMPEDANCE( $\Omega$ )	
		TYP.				TYP.	
		25 MHz	100 MHz			25 MHz	100 MHz
111	K3 RH 16.00x17.00x10.00	60	102	143	K3 RH 22.00x28.50x16.00	68	114
112	K3 RH 16.00x28.00x10.00	92	150	144	K3 RH 24.00x29.00x18.50	55	101
113	K3 RH 16.00x28.50x11.00	77	124	145	K3 RH 26.00x28.50x13.00	134	197
114	K3 RH 17.00x25.00x7.00	151	238	146	K3 RH 26.00x28.50x14.40	116	178
115	K3 RH 17.00x31.00x9.00	139	207	147	K3 RH 28.50x28.50x13.77	144	212
116	K3 RH 17.00x28.00x7.00	175	255	148	K3 RH 29.00x29.00x23.00	52	98
117	K3 RH 17.00x25.40x8.76	121	181	149	K3 RH 32.00x45.00x15.00	215	297
118	K3 RH 17.50x25.00x9.50	101	160				
119	K3 RH 17.50x28.50x9.50	122	186				
120	K3 RH 17.50x28.50x10.00	110	179				
121	K3 RH 17.50x28.50x10.70	98	156				
122	K3 RH 17.50x25.50x11.00	88	150				
123	K3 RH 18.20x28.20x9.90	120	190				
124	K3 RH 17.50x28.50x10.70	98	156				
125	K3 RH 17.50x25.50x11.00	88	150				
126	K3 RH 18.20x28.20x9.90	120	190				
127	K3 RH 18.40x28.00x9.50	110	189				
128	K3 RH 18.67x28.50x10.10	122	183				
129	K3 RH 18.67x34.00x10.10	141	228				
130	K3 RH 18.70x50.80x10.15	212	317				
131	K3 RH 18.70x28.50x11.20	104	165				
132	K3 RH 18.67x28.50x12.70	81	137				
133	K3 RH 19.00x50.80x11.50	184	280				
134	K3 RH 19.00x27.00x12.80	77	130				
135	K3 RH 19.00x29.10x13.00	82	134				
136	K3 RH 19.00x33.00x16.00	45	84	<b>TOLERANCE IN GENERAL</b> Under 6.0 $\pm 0.3$ Under 18.0~6.0 $\pm 0.5$ Under 24.0~18.0 $\pm 0.6$ Under 30.0~24.0 $\pm 0.8$ Under 40.0~30.0 $\pm 1.5$			
137	K3 RH 20.00x28.00x14.50	66	112				
138	K3 RH 20.50x28.50x11.50	110	178				
139	K3 RH 20.50x30.00x12.25	103	157				
140	K3 RH 21.00x37.00x9.00	214	305				
141	K3 RH 21.00x32.00x11.00	142	212				
142	K3 RH 21.00x28.50x13.00	95	153				

REMARK : 1.TOLERANCE CAN BE MODIFIED TO FIT SPECIFIED APPLICATION.  
2. OTHER SIZES AND MATERIAL ARE AVAILABLE UPON REQUEST

# RH CORES (CYLINDRICAL CORES)

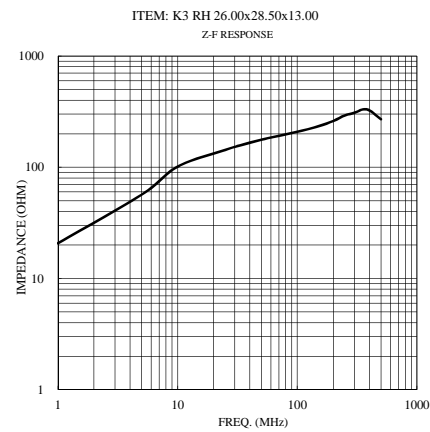
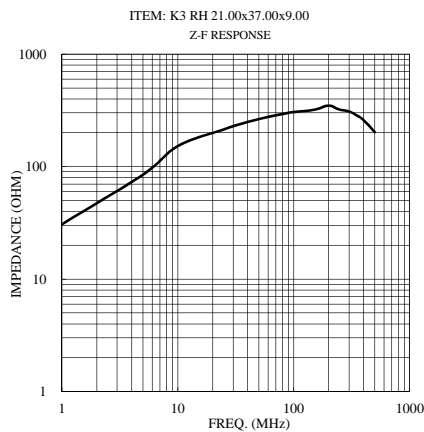
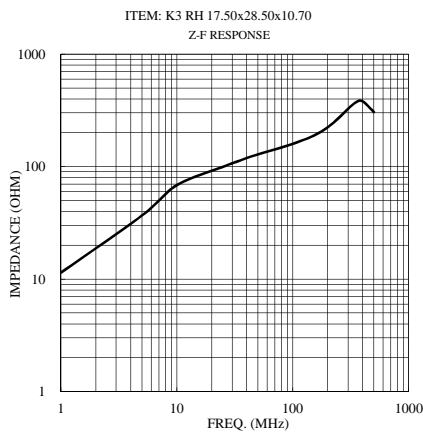
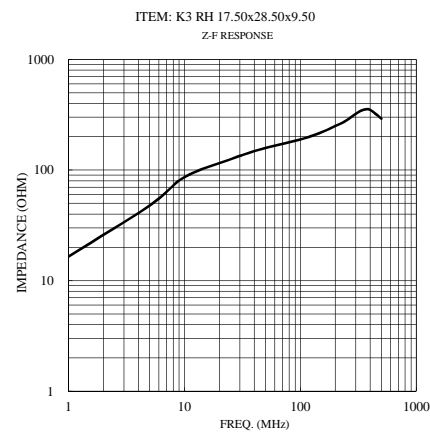
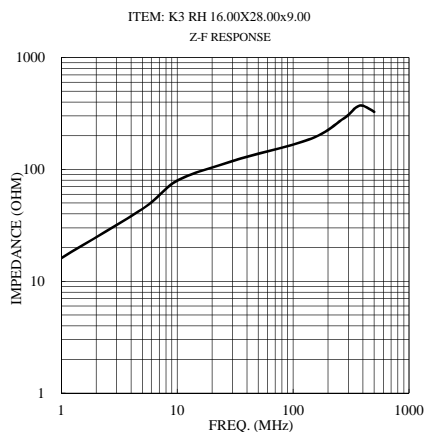
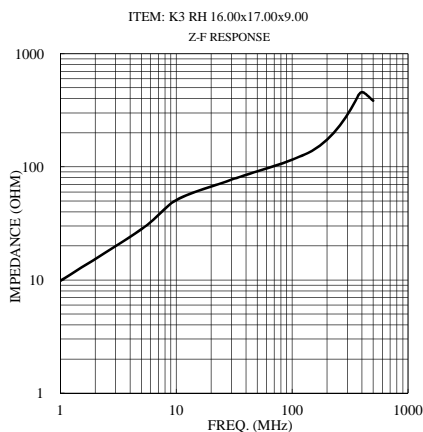
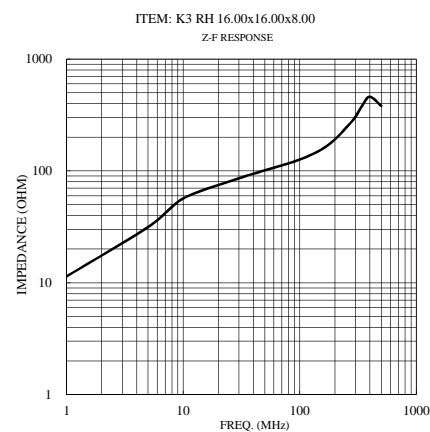
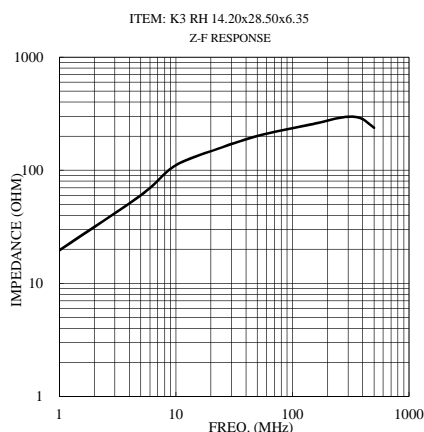
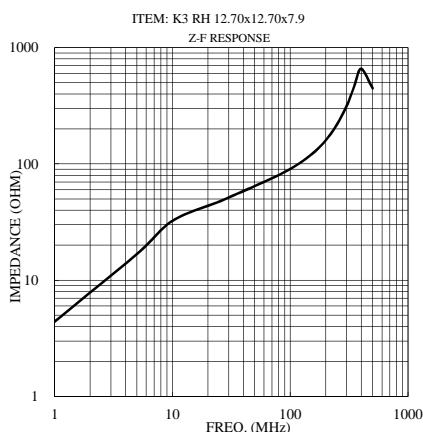
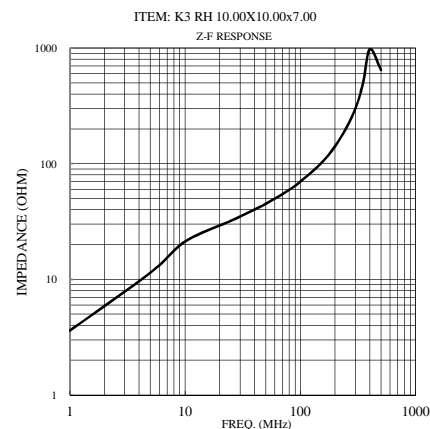
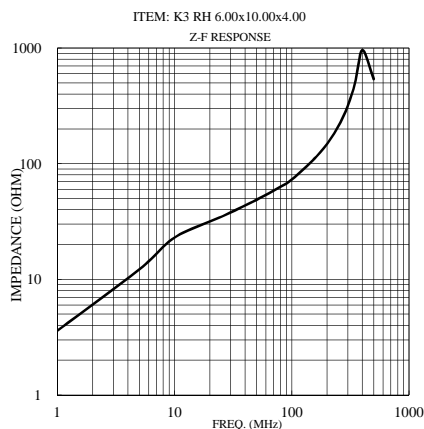
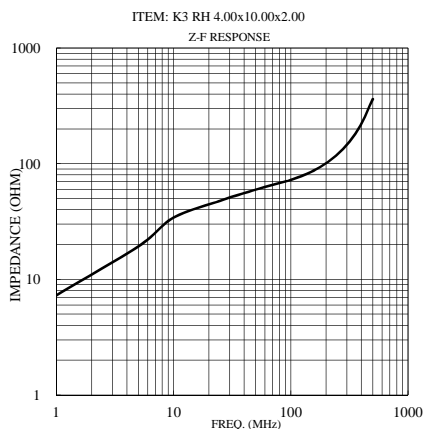

# T SERIES (TOROIDAL CORES)

---

## 1. ORDERING CODE

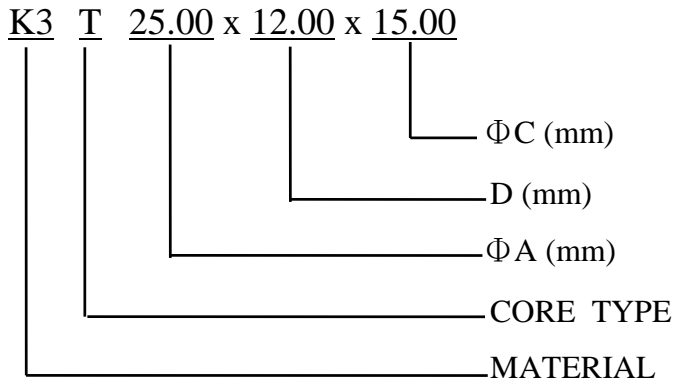

## 2. SHAPES

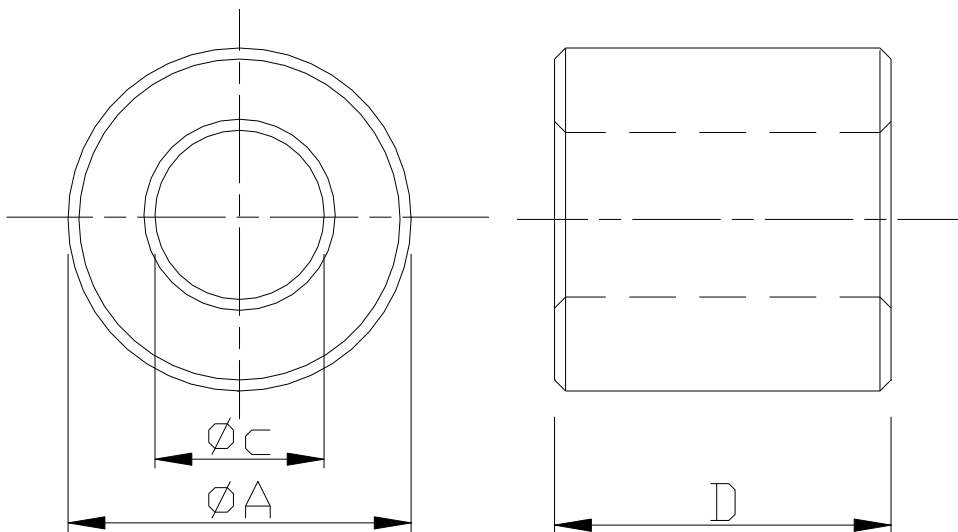

# T SERIES

## (TOROIDAL CORES)

### 3.DIMENSIONS

Unit:mm

NO.	FERRICO PART NO.	IMPEDANCE( $\Omega$ ) TYP.		NO.	FERRICO PART NO.	IMPEDANCE( $\Omega$ ) TYP.	
		25 MHz	100 MHz			25 MHz	100 MHz
1	— T 1.90x0.50x1.00			34	K3 T 9.10x4.60x5.00	27	62
2	— T 2.40x1.00x1.00			35	K3 T 9.50x4.80x5.00	27	65
3	— T 2.50x1.20x1.00			36	K3 T 10.00x4.00x6.00	23	60
4	— T 2.54x0.99x1.49			37	K3 T 10.00x5.00x5.00	30	67
5	— T 2.54x1.27x1.27			38	K3 T 10.00x5.00x7.00	20	59
6	— T 2.60x0.70x1.20			40	K3 T 10.30x10.20x5.80	47	85
7	— T 3.00x2.00x1.00			41	K3 T 10.50x10.00x7.00	32	75
8	— T 2.85x2.00x1.35			42	K3 T 11.00x9.00x5.00	52	94
9	— T 3.03x2.00x1.00			43	K3 T 11.80x8.00x7.80	28	67
10	— T 3.05x1.52x1.78			44	K3 T 12.00x3.00x6.00	22	60
11	— T 3.15x1.00x1.80			45	K3 T 12.00x4.00x7.50	22	61
12	— T 3.43x1.27x1.78			46	K3 T 12.00x6.00x7.00	28	66
13	— T 3.50x1.30x1.80			47	K3 T 12.00x7.00x5.60	38	76
14	— T 3.50x3.00x1.20			48	K3 T 12.00x10.00x7.50	37	78
15	— T 3.51x3.26x1.60			49	K3 T 12.00x11.50x8.50	32	71
16	— T 3.94x1.27x2.24			50	K3 T 12.70x6.40x7.90	30	66
17	— T 3.94x1.27x1.78			51	K3 T 13.00x6.00x7.00	33	70
18	— T 3.94x2.01x2.01			52	K3 T 13.00x10.00x7.00	47	85
19	K3 T 4.00x1.30x2.20	15	55	53	K3 T 13.00x12.50x7.00	56	98
20	K3 T 4.00x2.60x1.80	23	62	54	K3 T 14.00x5.00x7.00	27	65
21	K3 T 4.00x3.00x1.50	27	67	55	K3 T 14.00x5.00x9.00	23	58
22	K3 T 4.00x3.00x2.00	20	40	56	K3 T 14.00x5.00x10.00	21	62
23	K3 T 4.00x3.10x1.37	29	68	57	K3 T 14.00x7.00x8.00	28	64
24	K3 T 4.40x1.20x2.80	15	55	58	K3 T 14.00x8.00x10.00	28	63
25	K3 T 4.95x4.50x1.00	48	75	59	K3 T 14.20x10.20x6.35	60	101
26	K3 T 6.00x3.00x3.00	22	60	60	K3 T 14.20x5.00x7.00	30	65
27	K3 T 7.30x4.30x3.30	30	71	TOLERANCE IN GENERAL Under 6.0 $\pm 0.3$ Under 18.0~6.0 $\pm 0.5$ Under 24.0~18.0 $\pm 0.6$ Under 30.0~24.0 $\pm 0.8$ Under 40.0~30.0 $\pm 1.5$			
28	K3 T 7.60x4.20x3.60	32	66				
29	K3 T 8.00x3.00x4.00	24	60				
30	K3 T 8.00x4.00x4.00	27	65				
31	K3 T 9.00x5.00x4.50	30	67				
32	K3 T 9.00x3.00x5.00	23	60				
33	K3 T 9.00x8.00x5.00	39	81				

# T SERIES

## (TOROIDAL CORES)

Unit:mm

NO.	FERRICO PART NO.	IMPEDANCE( $\Omega$ ) TYP.		NO.	FERRICO PART NO.	IMPEDANCE( $\Omega$ ) TYP.	
		25 MHz	100 MHz			25 MHz	100 MHz
61	K3 T 14.50x5.50x8.50	27	65	93	K3 T 21.00x6.00x13.20	27	67
62	K3 T 14.50x8.00x10.00	27	65	94	K3 T 21.20x6.50x12.70	32	68
63	K3 T 15.00x12.00x10.50	37	78	95	K3 T 21.00x7.50x13.00	30	68
64	K3 T 16.00x4.80x9.00	55	90	96	K3 T 22.00x5.00x14.00	25	62
65	K3 T 16.00x5.00x10.00	25	61	97	K3 T 22.00x8.00x14.00	31	70
66	K3 T 16.00x6.00x9.00	32	70	98	K3 T 22.00x10.00x10.00	62	104
67	K3 T 16.00x8.00x10.00	34	75	99	K3 T 22.00x10.00x14.00	40	76
68	K3 T 16.00x8.00x12.00	25	62	100	K3 T 22.00x12.00x13.70	45	84
69	K3 T 16.00x12.00x9.00	50	95	101	K3 T 22.00x13.00x14.00	50	88
70	K3 T 16.00x13.00x8.00	68	108	102	K3 T 22.00x14.00x10.00	78	122
71	K3 T 16.00x13.00x9.00	57	98	103	K3 T 22.50x10.00x13.50	43	80
72	K3 T 16.00x13.50x12.00	35	70	104	K3 T 23.80x9.50x12.70	46	82
73	K3 T 16.00x15.00x9.00	65	97	105	K3 T 23.80x14.00x11.40	78	128
74	K3 T 16.50x13.00x8.00	67	112	106	K3 T 25.00x5.00x15.00	27	65
75	K3 T 16.50x16.00x8.20	82	131	107	K3 T 25.00x6.35x15.00	32	72
76	K3 T 17.50x6.35x9.50	35	70	108	K3 T 25.00x10.00x15.00	42	81
77	K3 T 17.50x11.00x9.50	52	88	109	K3 T 25.00x12.00x15.00	48	87
78	K3 T 17.50x12.70x9.50	57	100	110	K3 T 25.00x15.00x15.00	56	96
79	K3 T 17.50x14.50x9.50	60	105	111	K3 T 26.00x25.00x16.50	80	133
80	K3 T 18.00x6.00x10.00	30	65	112	K3 T 28.00x13.00x16.00	55	95
81	K3 T 18.00x7.00x10.00	36	75	113	K3 T 29.10x13.80x19.00	44	86
82	K3 T 18.00x10.00x10.00	46	85	114	K3 T 31.00x7.00x19.00	35	72
83	K3 T 18.00x6.00x12.00	27	66	115	K3 T 31.00x10.00x19.00	42	76
84	K3 T 18.45x10.25x9.75	52	94	116	K3 T 31.00x16.00x19.00	63	102
85	K3 T 18.67x14.27x10.10	64	108	<p>TOLERANCE IN GENERAL</p> <p>Under 6.0           <math>\pm 0.3</math></p> <p>Under 18.0~6.0   <math>\pm 0.5</math></p> <p>Under 24.0~18.0   <math>\pm 0.6</math></p> <p>Under 30.0~24.0   <math>\pm 0.8</math></p> <p>Under 40.0~30.0   <math>\pm 1.5</math></p>			
86	K3 T 8.70x15.00x12.70	46	85				
87	K3 T 19.00x8.00x12.00	35	72				
88	K3 T 19.00x10.00x10.00	50	88				
89	K3 T 20.00x5.00x10.00	32	69				
90	K3 T 20.00x10.00x10.00	51	95				
91	K3 T 20.00x10.00x12.00	40	75				
92	K3 T 21.00x6.00x12.70	28	70				



# T SERIES (TOROIDAL CORES)

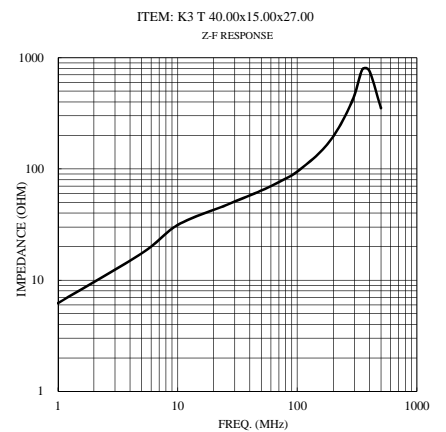
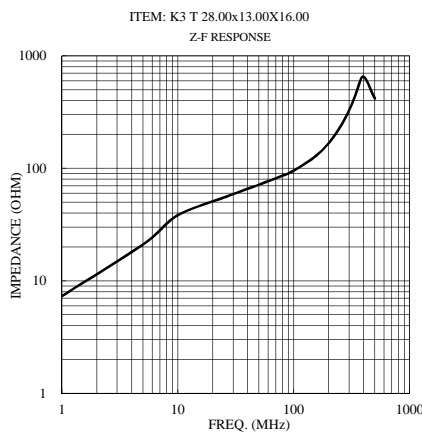
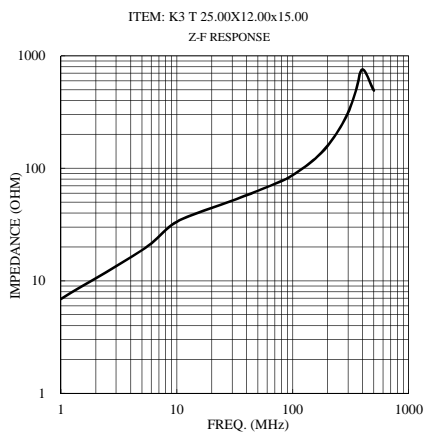
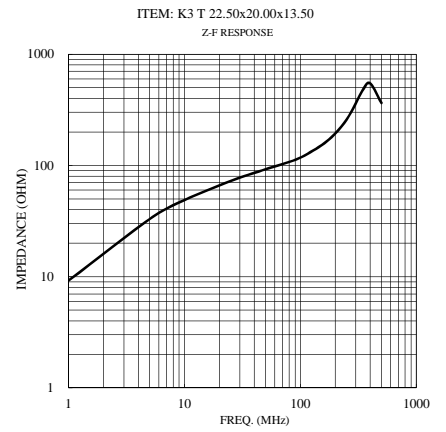
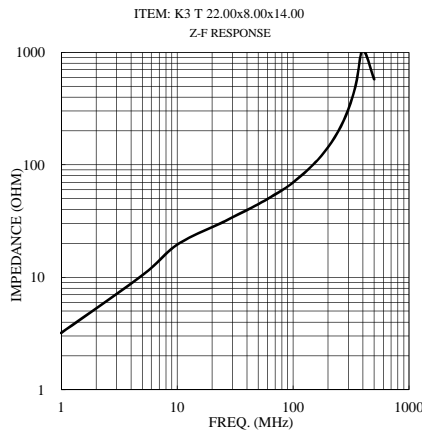
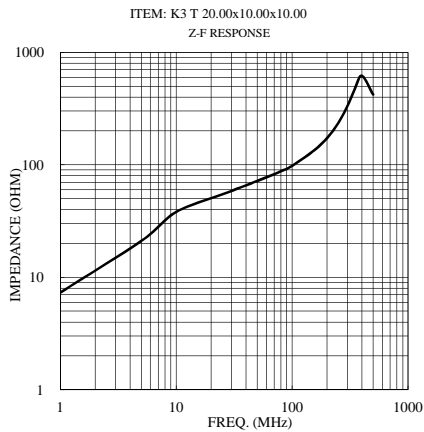
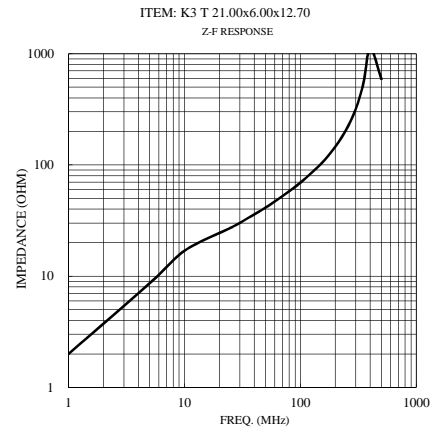
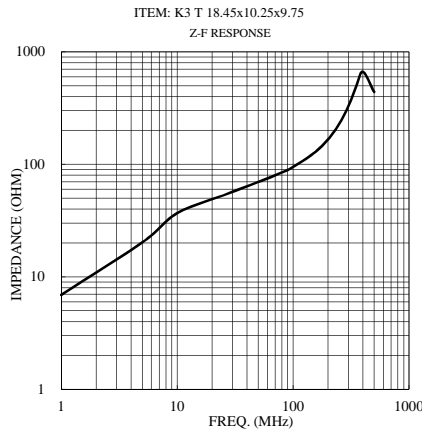
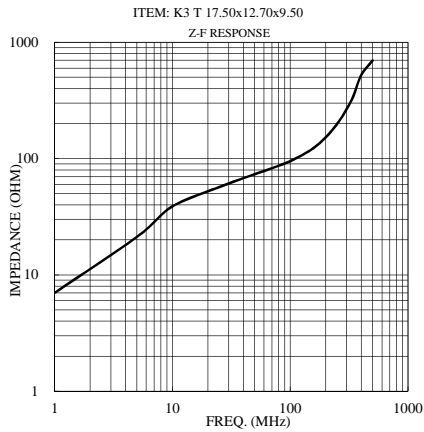
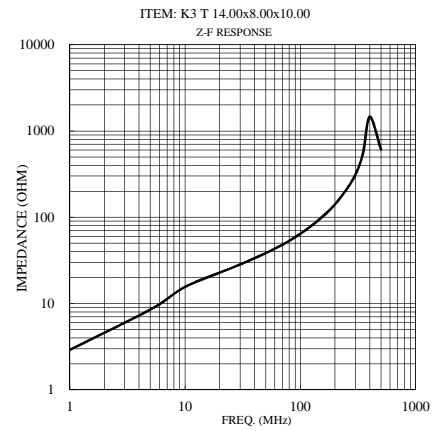
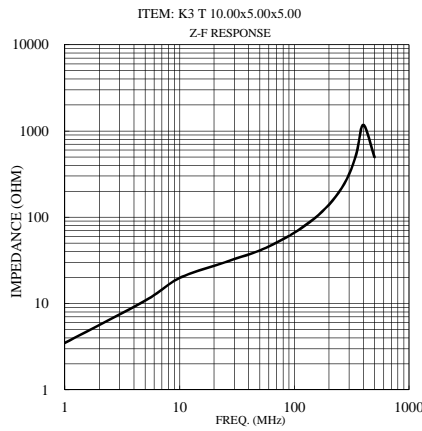
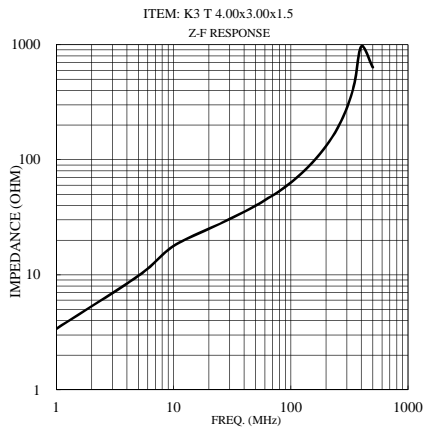

# R SERIES (ROD CORES)

## 1. ORDERING CODE

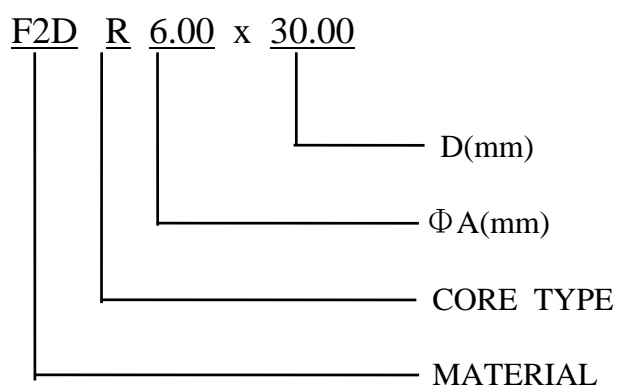

## 2. SHAPES

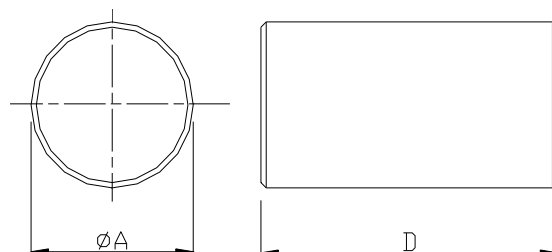

## 3. DIMENSIONS

Unit: mm

NO.	FERRICO PART NO.	ΦA	D	NO.	FERRICO PART NO.	ΦA	D
1	___R 0.53x1.40	0.53±0.08	1.4±0.12	16	___R 4.00x35.00	4.0±0.15	35.0±1.0
2	___R 0.90x1.90	0.9±0.08	1.9±0.1	17	___R 4.50x4.30	4.5±0.15	4.3±0.2
3	___R 1.20x4.50	1.2 <sup>±0</sup> <sub>±0.1</sub>	4.5±0.2	18	___R 5.00x25.00	5.0±0.2	25.0±0.8
4	___R 1.50x4.20	1.5±0.1	4.2±0.2	19	___R 6.00x20.00	6.0±0.2	20.0±0.5
5	___R 1.60x17.90	1.6±0.15	17.9±0.6	20	___R 6.00x30.00	6.0±0.2	30.0±1.0
6	___R 1.70x13.00	1.7±0.15	13.0±0.4	21	___R 6.00x40.00	6.0±0.3	40.0±1.0
7	___R 1.85x5.50	1.85±0.1	5.5±0.3	22	___R 6.50x32.00	6.5±0.2	32.0±0.8
8	___R 2.00x10.00	2.0±0.1	10.0±0.3	23	___R 7.30x20.00	7.3±0.2	20.0±0.6
9	___R 2.50x10.00	2.5±0.1	10.0±0.3	24	___R 8.00x20.00	8.0±0.3	20.0±0.6
10	___R 2.50x19.00	2.5±0.1	19.0±0.6	25	___R 8.00x30.00	8.0±0.3	30.0±0.8
11	___R 3.00x8.00	3.0±0.1	8.0±0.3	26	___R 10.00x27.00	10.0±0.4	27.0±1.0
12	___R 3.00x25.00	3.0±0.1	25.0±0.8	27	___R 11.50x40.00	11.5±0.3	40.0±1.0
13	___R 3.30x17.00	3.0±0.1	17.0±0.3	28	___R 12.00x25.00	12.0±0.4	25.0±0.8
14	___R 3.50x17.50	3.5±0.15	17.5±0.5	29	___R 12.90x18.00	12.9±0.4	18.0±0.5
15	___R 4.00x30.00	4.0±0.15	30.0±1.0	30	___R 15.00x15.50	15.0±0.4	15.5±0.4

REMARK : OTHER SIZES ARE AVAILABLE UPON REQUEST

# RWW SERIES

## (COIL FORM)

### 1. ORDERING CODE

F2D RWW 4.00 x 12.00

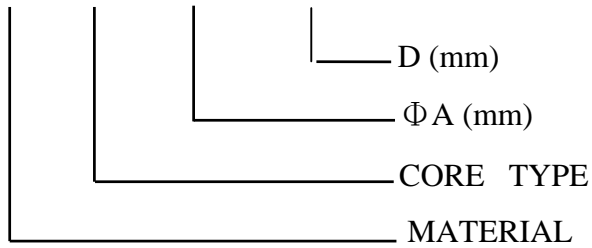

### 2. SHAPES

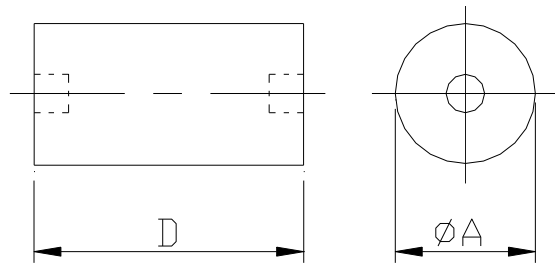

### 3. DIMENSIONS

Unit: mm

NO.	FERRICO PART NO.	Φ A	D
1	___ RWW 3.00x12.00	3.0±0.15	12.0±0.5
2	___ RWW 4.00x10.00	4.0±0.15	10.0±0.3
3	___ RWW 4.00x30.00	4.0±0.15	30.0±0.8
4	___ RWW 5.00x12.00	5.0±0.15	12.0±0.5
5	___ RWW 5.00x18.00	5.0±0.15	18.0±0.5
6	___ RWW 6.00x30.00	6.0±0.2	30.0±0.8
7	___ RWW 10.00x12.00	10.0±0.2	12.0±0.5
8	___ RWW 10.00x25.00	10.0±0.2	25.0±0.5

REMARK : OTHER SIZES ARE AVAILABLE UPON REQUEST



# RHH/R3H/R4H/R6H SERIES

## (WIDE BAND CHOKE CORES)

### 1. ORDERING CODE

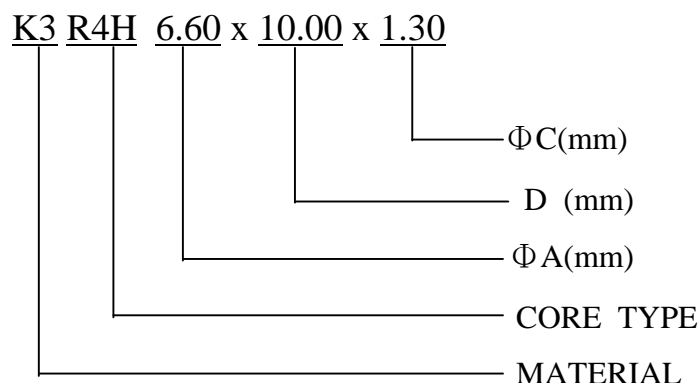

### 2. SHAPES

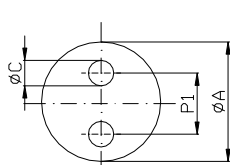

Fig.1 RHH

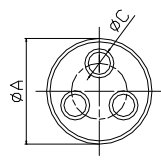

Fig.2 R3H

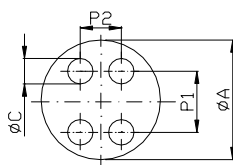

Fig.3 R4H

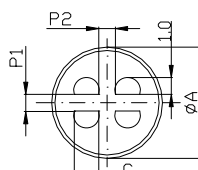

Fig.4 R4H

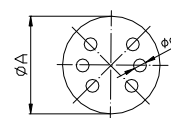

Fig.5 R6H

### 3. DIMENSIONS

Unit: mm

NO.	FERRICO PART NO.	Fig.	ΦA	D	ΦC/C	P1	P2
1	___RHH 6.00x5.50x1.45	1	6.0±0.3	5.5±0.3	1.45±0.15	2.6±0.1	
2	___RHH 7.00x5.50x1.40	1	7.0±0.5	5.5±0.5	1.4±0.1	2.7±0.1	
3	___R3H 16.00x28.00x4.40	2	16.0±0.4	28.0±0.6	4.4±0.25		
4	___R4H 6.60x10.00x1.30	3	6.6±0.5	10.0±0.3	1.3±0.1	2.2	2.2
5	___R4H 6.60x3.50x1.45	4	6.6±0.5	3.5±0.3	1.45±0.15	1.0	1.0
6	___R4H 8.00x5.00x1.20	3	8.0±0.3	5.0±0.3	1.2 <sup>+0.3</sup> <sub>0</sub>	3.0	3.0
7	___R6H 6.00x10.00x0.80	5	6.0±0.3	10.0±0.4	0.87 REF		

REMARK : OTHER SIZES AND MATERIAL ARE AVAILABLE UPON REQUEST

# SPMF SERIES

## (PCB MOUNTING FILTER)

### 1. ORDERING CODE

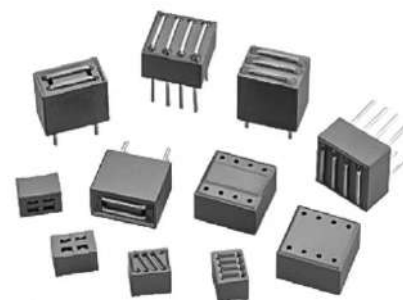
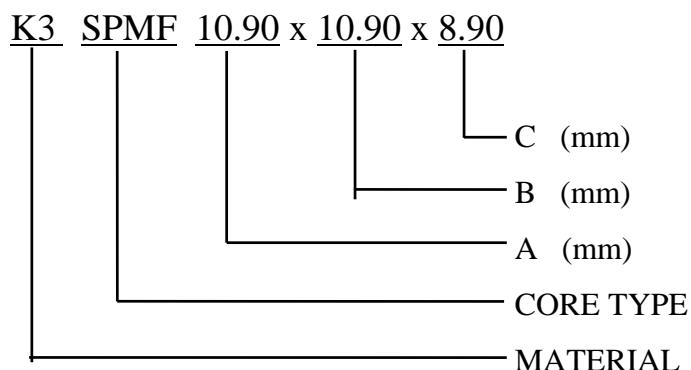

### 2. SHAPES

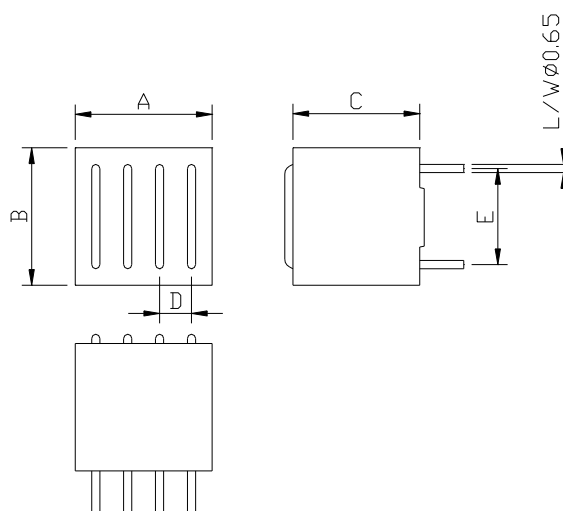

### 3. DIMENSIONS

Unit: mm

NO.	FERRICO PART NO.	LINES	A	B	C	D	E
1	__SPMF 8.34x10.90x10.10	3	8.34±0.25	10.9±0.3	10.1±0.3	2.54±0.1	7.62 REF
2	__SPMF 10.88x5.49x10.00	4	10.88±0.3	5.49±0.25	10.0±0.3	2.54±0.2	2.54±0.2
3	__SPMF 10.90x10.90x5.00	4	10.9±0.3	10.9±0.3	5.0±0.3	2.54±0.1	7.62 REF
4	__SPMF 10.90x10.90x6.35	4	10.9±0.3	10.9±0.3	6.35±0.3	2.54±0.1	7.62 REF
5	__SPMF 10.90x10.90x8.90	4	10.9±0.3	10.9±0.3	8.9±0.3	2.54±0.1	7.62 REF
6	__SPMF 10.90x10.90x10.10	4	10.9±0.3	10.9±0.3	10.1±0.3	2.54±0.1	7.62 REF

REMARK : OTHER SIZES AND MATERIAL ARE AVAILABLE UPON REQUEST

# SPMF SERIES (PCB MOUNTING FILTER)

ITEM: K3 SPMF 8.34 x 10.90 x 10.10

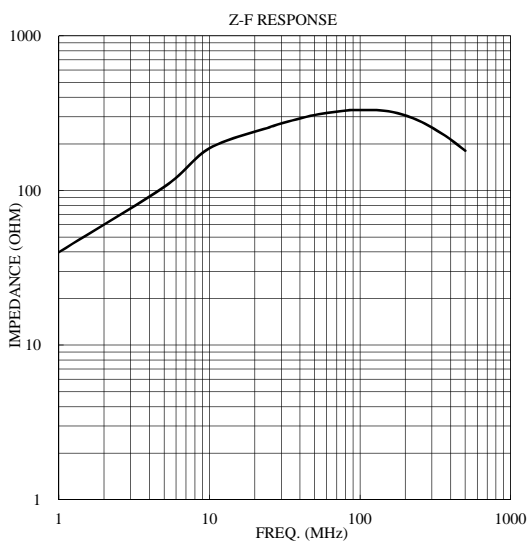

ITEM: K3 SPMF 10.88x5.49x10.00

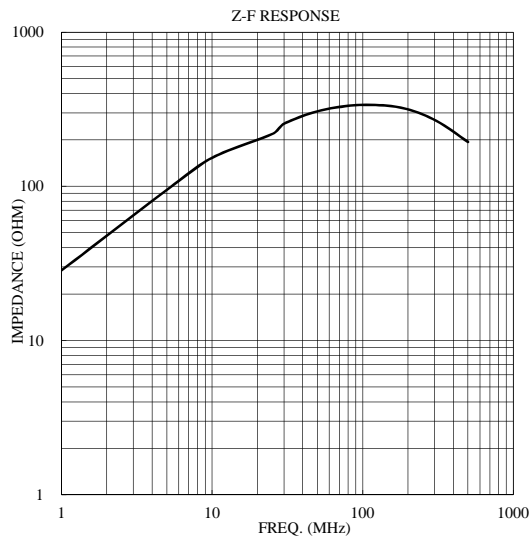

ITEM: K3 SPMF 10.90 x 10.90 x 5.00

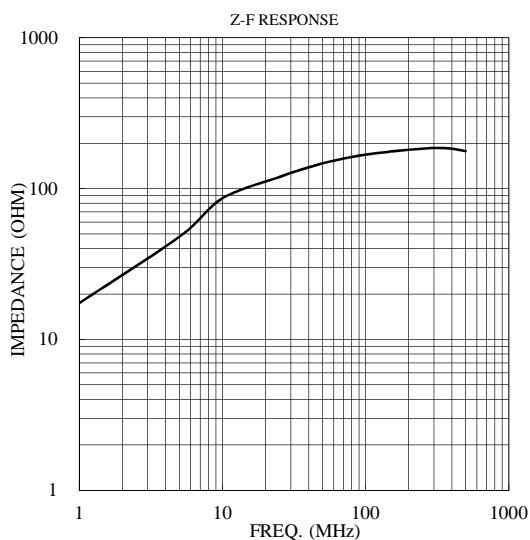

ITEM: K3 SPMF 10.90 x 10.90 x 6.35

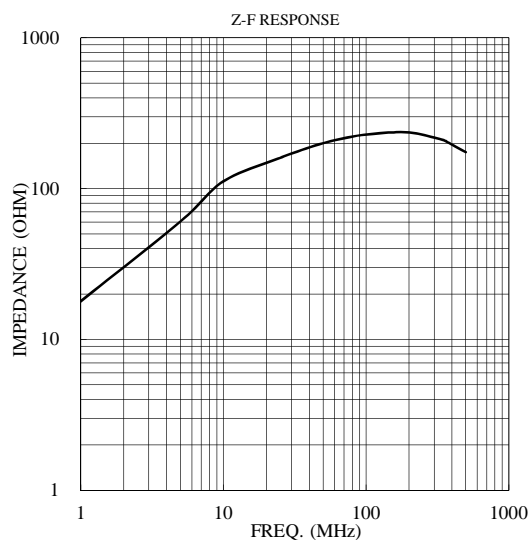

ITEM: K3 SPMF 10.90 x 10.90 x 8.90

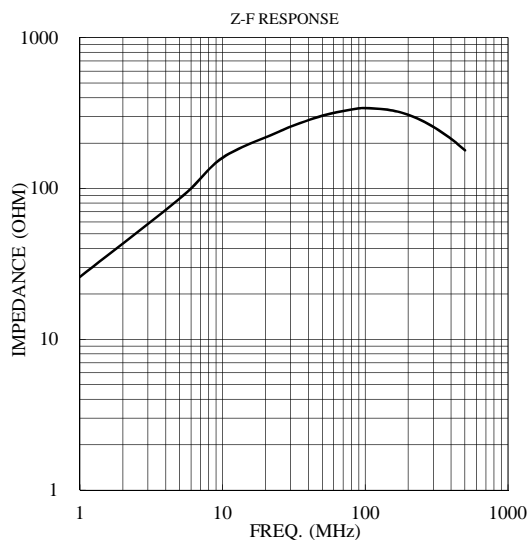

ITEM: K3 SPMF 10.90 x 10.90 x 10.1

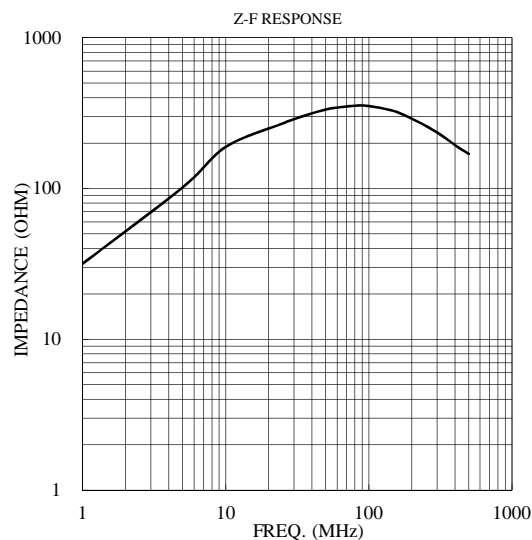





# DS SERIES

## (CONNECTOR SUPPRESSION PLATES)

### 1. ORDERING CODE

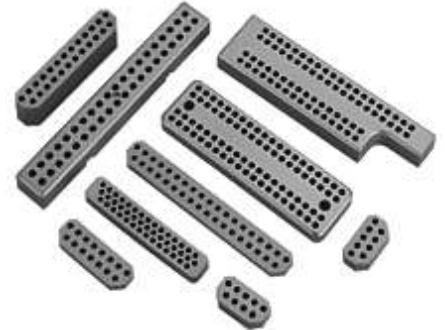
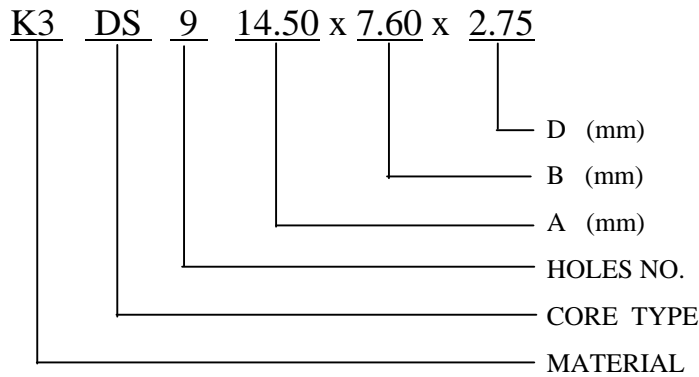

### 2. SHAPES

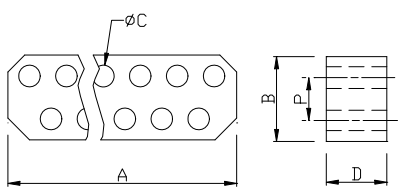

Fig.1

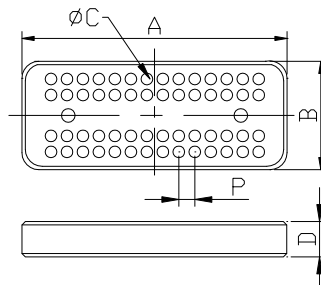

Fig.2

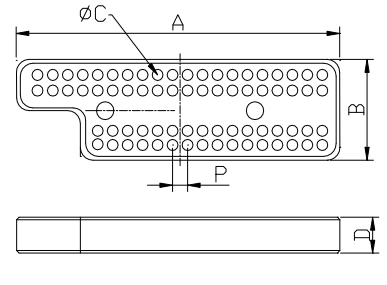

Fig.3

### 3. DIMENSIONS

Unit: mm

NO.	FERRICO PART NO.	Fig.	A	B	ΦC	D	P
1	—DS9 14.50x7.60x2.75	1	14.50 $\pm$ <sub>0.7</sub> <sup>0</sup>	7.60 $\pm$ 0.5	1.57 $\pm$ <sub>0</sub> <sup>0.15</sup>	2.75 $\pm$ 0.1	2.84 $\pm$ 0.15
2	—DS15 22.65x7.60x2.75	1	22.65 $\pm$ <sub>0.3</sub> <sup>0.1</sup>	7.60 $\pm$ 0.5	1.57 $\pm$ <sub>0</sub> <sup>0.1</sup>	2.75 $\pm$ 0.1	2.84 $\pm$ 0.15
3	—DS25 36.40x7.60x2.75	1	36.40 $\pm$ <sub>0.3</sub> <sup>0.1</sup>	7.60 $\pm$ 0.5	1.57 $\pm$ <sub>0</sub> <sup>0.15</sup>	2.75 $\pm$ 0.1	2.84 $\pm$ 0.15
4	—DS37 53.08x7.70x2.50	1	53.08 $\pm$ 0.5	7.70 $\pm$ 0.5	1.57 $\pm$ <sub>0</sub> <sup>0.15</sup>	2.50 $\pm$ 0.1	2.84 $\pm$ 0.15
5	—DS56 39.00x16.42x4.00	2	39.0 $\pm$ 0.4	16.42 $\pm$ 0.4	1.84 $\pm$ 0.08	4.0 $\pm$ 0.25	2.54 REF.
6	—DS72 54.24x16.42x4.00	3	54.24 $\pm$ 0.5	16.42 $\pm$ 0.4	1.84 $\pm$ 0.08	4.0 $\pm$ 0.25	2.54 REF.
7	—DS80 54.24x16.42x4.00	2	54.24 $\pm$ 0.5	16.42 $\pm$ 0.4	1.84 $\pm$ 0.08	4.0 $\pm$ 0.25	2.54 REF.

REMARK : OTHER SIZES AND MATERIAL ARE AVAILABLE UPON REQUEST

# DS SERIES (CONNECTOR SUPPRESSION PLATES)

ITEM: K3 DS9 14.50x7.60x2.75  
Z-F RESPONSE

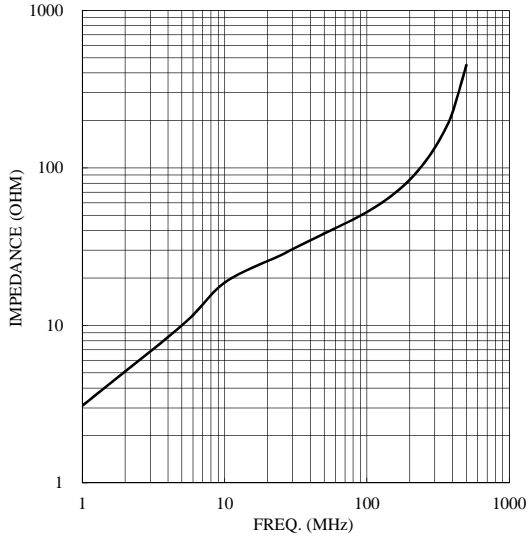

ITEM: K3 DS15 22.65x7.60x2.75  
Z-F RESPONSE

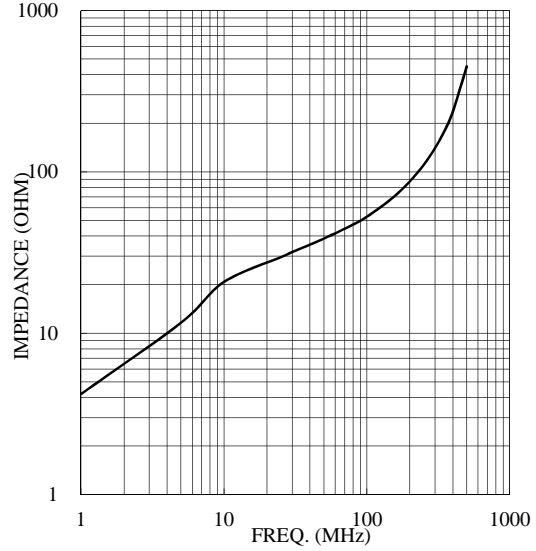

ITEM: K3 DS25 36.40x7.60x2.75  
Z-F RESPONSE

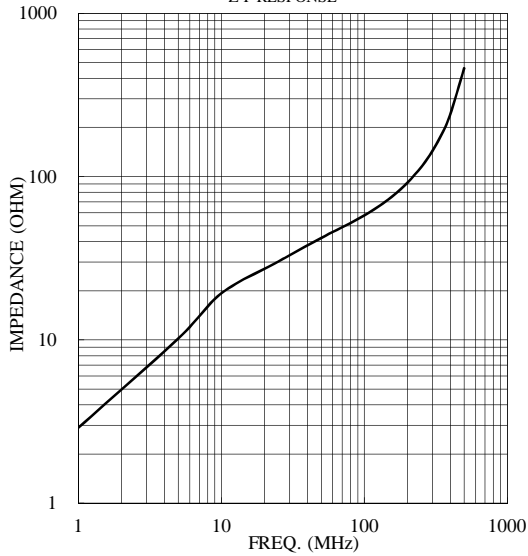

ITEM: K3 DS37 53.08x7.70x2.50  
Z-F RESPONSE

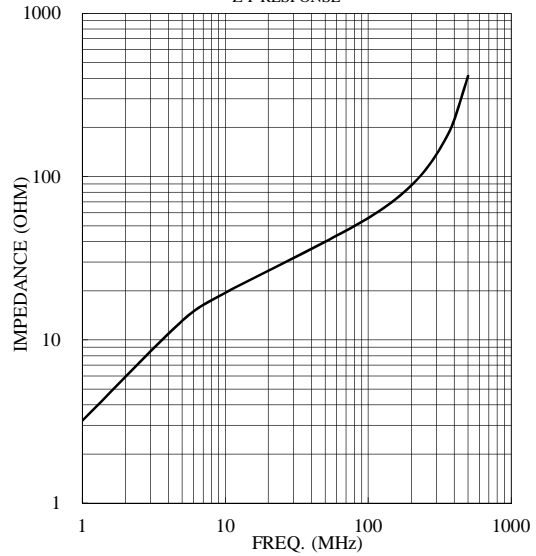

# DIR SERIES

## (SMD CHIP INDUCTOR CORES)

### 1. ORDERING CODE

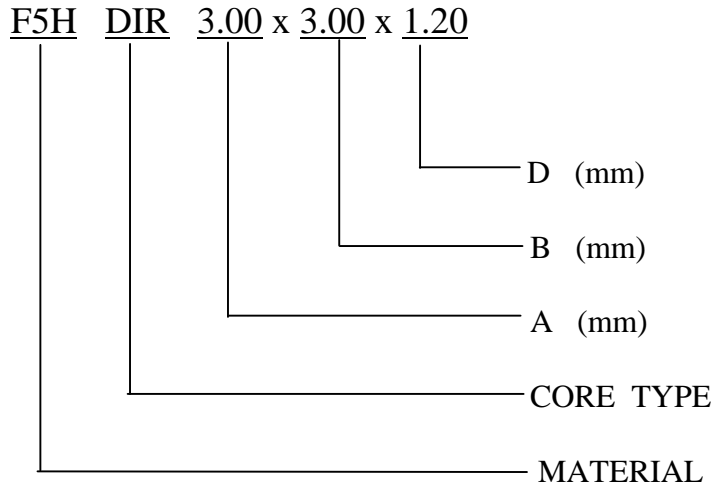

### 2. SHAPES

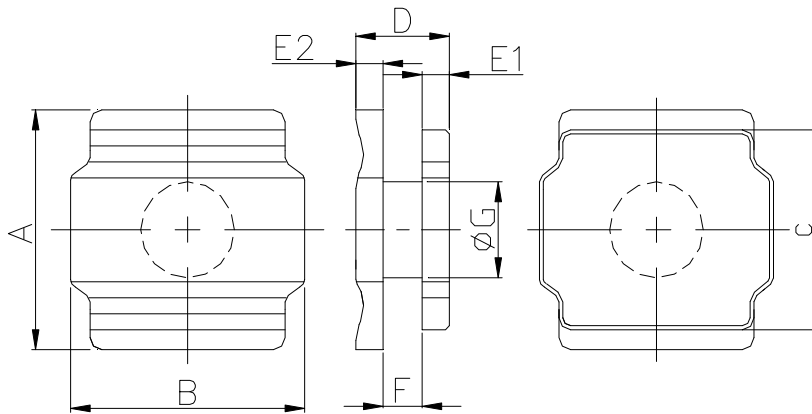

Fig.1

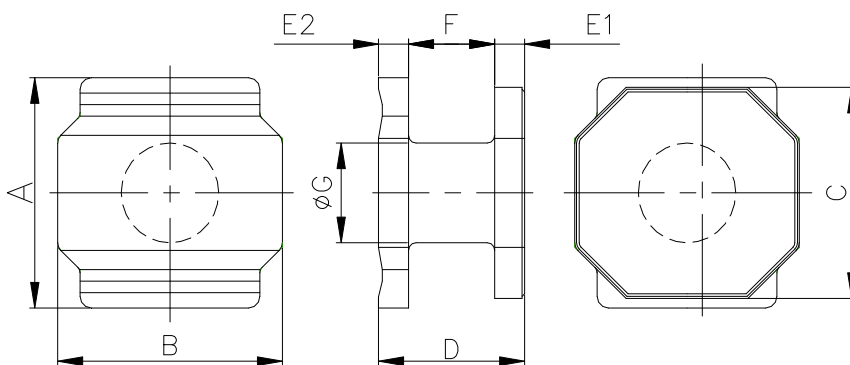

Fig.2

# DIR SERIES

## (SMD CHIP INDUCTOR CORES)

### 3.DIMENSIONS

Unit: mm

NO.	FERRICO PART NO.	Fig.	A	B	C	D	E1	F	E2	ΦG
1	F5H DIR 3.00x3.00x1.20	1	3.0±0.08	3.0±0.08	2.5±0.08	1.2±0.08	0.3±0.05	0.5±0.05	0.4±0.05	1.2±0.08
2	F5H DIR 3.00x3.00x1.35	2	3.0±0.08	3.0±0.08	2.5±0.08	1.35±0.08	0.35±0.05	0.6±0.07	0.4±0.05	1.3±0.08
3	F5H DIR 4.00x4.00x2.30	1	4.0±0.1	4.0±0.1	3.5±0.1	2.3±0.1	0.5±0.08	1.0±0.08	0.8±0.08	1.8±0.08
4	F5H DIR 5.00x5.00x2.30	2	5.0±0.1	5.0±0.1	4.5±0.1	2.3±0.1	0.45±0.07	1.3±0.1	0.55±0.07	2.6±0.1
5	F5H DIR 5.60x5.00x4.70	1	5.6±0.2	5.0±0.15	5.0±0.15	4.7±0.15	0.9±0.10	2.5±0.15	1.3±0.10	3.0±0.15
6	F5H DIR 6.00x6.00X2.55	2	6.0±0.1	6.0±0.1	5.5±0.1	2.55±0.1	0.6±0.1	1.3±0.1	0.65±0.1	3.0±0.1
7	F5H DIR 7.00x7.00x2.30	2	7.0±0.1	7.0±0.1	6.5±0.1	2.3±0.1	0.45±0.07	1.3±0.1	0.55±0.07	4.0±0.1
8	F5H DIR 7.00x7.00X2.55	2	7.0±0.1	7.0±0.1	6.5±0.1	2.55±0.1	0.6±0.1	1.3±0.1	0.65±0.1	4.0±0.1
9	F5H DIR 8.00x8.00x2.30	2	8.0±0.1	8.0±0.1	7.5±0.1	2.3±0.1	0.6±0.1	1.05±0.1	0.65±0.1	5.0±0.1
10	F5H DIR 8.00x8.00X2.55	2	8.0±0.1	8.0±0.1	7.5±0.1	2.55±0.1	0.6±0.1	1.3±0.1	0.65±0.1	5.0±0.1
11	F5H DIR 8.00x8.00X3.70	1	8.0±0.1	8.0±0.1	7.5±0.1	3.7±0.1	0.7±0.1	2.0±0.1	1.0±0.1	3.5±0.1
12	F5H DIR 8.00x8.00X3.70	2	8.0±0.1	8.0±0.1	7.5±0.1	3.7±0.1	0.7±0.1	2.2±0.1	0.8±0.1	3.6±0.1
13	F5H DIR 10.00x10.00X2.55	2	10.0±0.1	10.0±0.1	9.5±0.1	2.55±0.1	0.6±0.1	1.3±0.1	0.65±0.1	6.0±0.1
14	F5H DIR 10.00x10.00X3.70	2	10.0±0.1	10.0±0.1	9.5±0.1	3.7±0.1	0.8±0.1	2.0±0.1	0.9±0.1	5.5±0.1

REMARK: OTHER SIZES ARE AVAILABLE UPON REQUEST

# DR SERIES (DRUM CORES)

## 1.ORDERING CODE

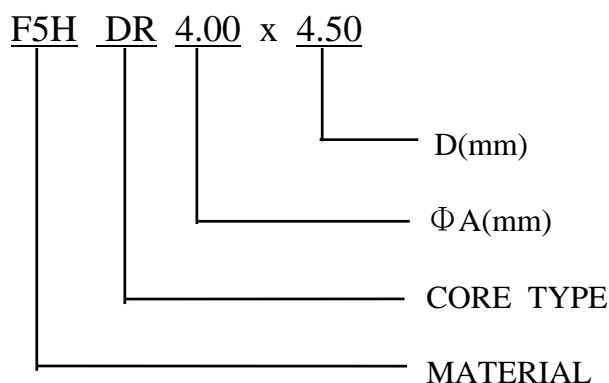

## 2.SHAPES

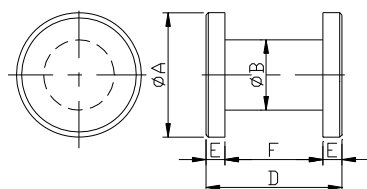

Fig.1

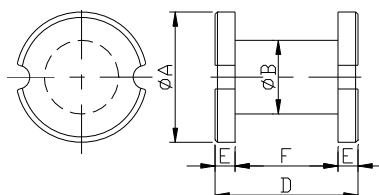

Fig.2

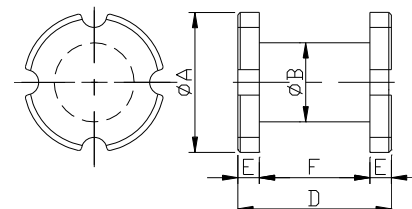

Fig.3

## 3.DIMENSIONS

Unit:mm

NO.	FERRICO PART NO.	Fig.	ΦA	ΦB	D	E	F
1	DR 2.60x0.80	1	2.6±0.10	1.0±0.07	0.8±0.07	0.25±0.07	0.3±0.07
2	DR 2.70x1.30(S)	2	2.7±0.10	0.98±0.07	1.3±0.10	0.3±0.07	0.7±0.07
3	DR 3.20x0.90	1	3.2±0.10	2.0±0.10	0.9±0.10	0.3±0.10	0.3±0.10
4	DR 4.20x0.80	1	4.2± <sup>0</sup> <sub>0.2</sub>	2.0±0.10	0.8±0.07	0.275±0.07	0.25±0.05
5	DR 4.30x0.80	1	4.3±0.10	2.0±0.10	0.8± <sup>0</sup> <sub>0.1</sub>	0.28REF.	0.2±0.07
6	DR 3.90x3.00(4S)	3	3.9± <sup>0.05</sup> <sub>0.20</sub>	1.5±0.15	3.0± 0.20	0.75REF.	1.5±0.10
7	DR 4.00x3.00	1	4.0± <sup>0</sup> <sub>0.20</sub>	2.0±0.15	3.0± 0.20	0.75REF.	1.5±0.10
8	DR 4.50x5.80	1	4.5±0.15	2.2±0.15	5.8±0.20	0.9±0.10	4.0±0.10
9	DR 5.30x3.60	1	5.3±0.20	2.8±0.20	3.6±0.20	0.5 REF	2.6±0.20
10	DR 6.80x4.00(S)	2	6.8±0.20	3.0±0.15	4.0±0.20	0.85±0.10	2.3±0.15
11	DR 8.00x4.00(S)	2	8.0±0.20	3.6±0.20	4.0±0.20	0.95±0.15	2.1±0.15
12	DR 8.00x10.00	1	8.0±0.20	3.0±0.15	10.0±0.20	1.5±0.15	7.0±0.20
13	DR 8.70x4.20	1	8.7±0.20	3.3±0.15	4.2±0.20	0.78±0.15	2.65±0.20
14	DR 9.00x12.00	1	9.0±0.30	4.5±0.20	12.0±0.30	3.2 REF	5.6±0.20
15	DR 10.00x11.00(S)	2	10.0±0.15	6.1±0.20	11.0±0.15	2.35±0.10	6.3±0.15
16	DR 10.00x12.50	1	10.0±0.20	4.0±0.15	12.5±0.30	2.0±0.15	8.5±0.20
17	DR 12.00x15.00(S)	2	12.0±0.30	6.0±0.20	15.0±0.30	2.1±0.20	10.8±0.20
18	DR 14.00x15.00(S)	2	14.0±0.50	7.0±0.20	15.0±0.50	2.5 REF.	10.0±0.25
19	DR 15.00x12.00	1	15.0±0.30	4.5±0.20	12.0±0.30	3.0±0.20	6.0±0.20
20	DR 15.00x15.00(S)	2	15.0±0.20	7.0±0.20	15.0±0.20	3.0±0.20	9.0±0.20

REMARK:OTHER SIZES ARE AVAILABLE UPON REQUEST

# DR SERIES (COIL FORM)



## 1.ORDERING CODE

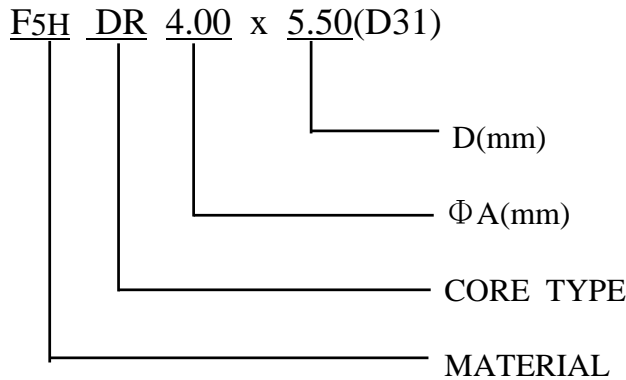

## 2.SHAPES

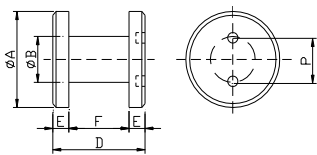

Fig. 1

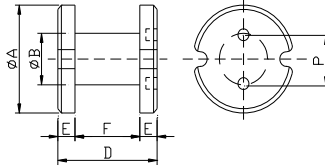

Fig. 2

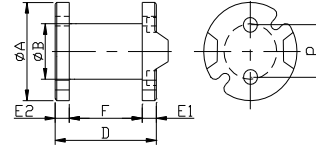

Fig. 3

## 3.DIMENSIONS

Unit:mm

NO.	FERRICO PART NO.	Fig.	ΦA	ΦB	D	E/E2	F	P
1	___DR 4.00x5.50(D31)	1	4.0±0.15	2.0±0.15	5.5±0.30	1.6±0.15	2.3±0.15	2.0
2	___DR 4.50x7.00(S)(D31)	3	4.5±0.08	2.0±0.10	7.0±0.15	1.4±0.1/1.0±0.1	3.9±0.15	2.5
3	___DR 5.00x4.60(D31)	1	5.0±0.15	2.5±0.15	4.6±0.15	1.3 REF.	2.0±0.15	2.5
4	___DR 6.00x8.00(D31)	1	6.0±0.20	3.0±0.15	8.0±0.30	2.0±0.15	4.0±0.15	3.0
5	___DR 6.00x8.00(S)(D31)	2	6.0±0.20	3.0±0.15	8.0±0.30	1.8 REF.	4.4±0.20	3.6
6	___DR 7.80x10.00(S)(D31)	3	7.8±0.20	3.0±0.20	10.0 <sup>0</sup> <sub>±0.3</sub>	2.0/2.0REF.	5.0±0.20	5.0
7	___DR 8.00x8.00(S)(D31)	2	8.0±0.15	3.0±0.15	8.0±0.30	2.0±0.15	4.0±0.15	5.0
8	___DR 8.00x9.00(D31)	1	8.0±0.15	3.5±0.15	9.0±0.30	2.0±0.15	5.0±0.15	5.0
9	___DR 8.00x10.10(S)(D31)	3	8.0 <sup>0.1</sup> <sub>±0.2</sub>	4.45±0.15	10.1±0.20	1.8±0.15/1.3±0.15	6.0±0.15	5.0
10	___DR 8.00x12.00(D31)	1	8.0±0.20	4.1±0.15	12.0±0.40	2.5±0.15	7.0±0.20	5.0
11	___DR 8.50x9.00(S)(D31)	3	8.5MAX	3.5±0.15	9.0MAX	1.2/1.8REF.	4.8MIN	5.0
12	___DR 9.00x12.00(D31)	1	9.0±0.30	4.0±0.20	12.0±0.30	2.5±0.105	7.0±0.20	5.0
13	___DR 10.00x12.00(D31)	1	10.0±0.30	3.5±0.20	12.0±0.30	2.35±0.105	7.3±0.20	5.0
14	___DR 11.00x10.00(S)(D31)	2	11.0±0.30	4.5±0.30	10.0±0.30	2.0 REF.	6.0±0.30	5.0
15	___DR 12.00x15.00(S)(D31)	2	12.0±0.30	6.0±0.20	15.0±0.30	3.0±0.15	9.0±0.20	7.5
16	___DR 16.00x10.00(S)(D31)	2	16.0±0.30	9.8±0.20	10.0±0.30	2.25±0.15	5.5±0.15	9.5

REMARK : OTHER SIZES ARE AVAILABLE UPON REQUEST

# DR SERIES (COIL FORM)

## 1. ORDERING CODE

F5H DR 5.00 x 8.00 (S) (D29)

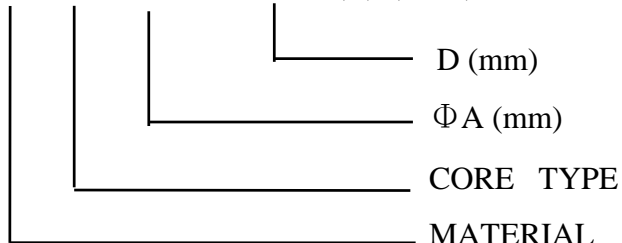

## 2. SHAPES

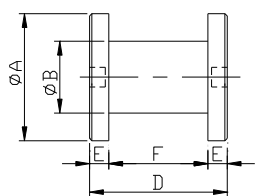

Fig.1

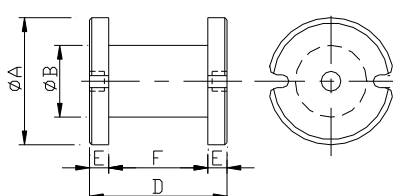

Fig.2

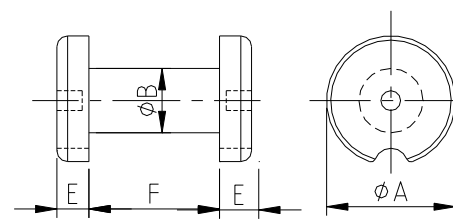

Fig.3

## 3. DIMENSIONS

Unit: mm

NO.	FERRICO PART NO.	Fig.	ΦA	ΦB	D	E	F
1	___ DR 3.00x6.00(D29)	1	3.0±0.15	2.0±0.15	6.0±0.30	1.5±0.15	3.0±0.15
2	___ DR 4.00x5.50(D29)	1	4.0±0.15	2.0±0.15	5.5±0.30	1.6±0.15	2.3±0.15
3	___ DR 4.00x10.00(D29)	1	4.0±0.15	2.4±0.15	10.0±0.30	1.5±0.15	7.0±0.20
4	___ DR 4.00x10.00(S)(D29)	2	4.0±0.15	2.0±0.15	10.0±0.30	1.5REF.	7.0 <sup>+0.10</sup> <sub>-0.20</sub>
5	___ DR 5.00x8.00(S)(D29)	2	5.0±0.15	2.5±0.15	8.0±0.20	2.0±0.15	4.0±0.20
6	___ DR 5.00x12.00(D29)	1	5.0±0.15	3.0±0.15	12.0±0.30	2.1±0.15	7.8±0.20
7	___ DR 5.00x12.00(S)(D29)	3	5.0±0.15	3.0±0.15	12.0±0.30	2.0±0.15	8.0±0.20
8	___ DR 6.00x8.00(S)(D29)	2	6.0±0.20	2.5±0.15	8.0±0.30	2.0±0.15	4.0±0.15
9	___ DR 6.80x11.70 (S)(D29)	2	6.8±0.20	3.8±0.10	11.7±0.30	1.35±0.20	9.0±0.30
10	___ DR 6.00x12.00(D29)	1	6.0±0.20	3.5±0.15	12.0±0.30	4.0±0.20	4.0±0.15
11	___ DR 10.00x20.00(S)(D29)	2	10.0±0.30	5.0±0.15	20.0±0.40	3.0±0.20	14.0±0.30

REMARK : OTHER SIZES ARE AVAILABLE UPON REQUEST

# DR&RI SERIES

## (SMD INDUCTOR CORES)

### 1. ORDERING CODE

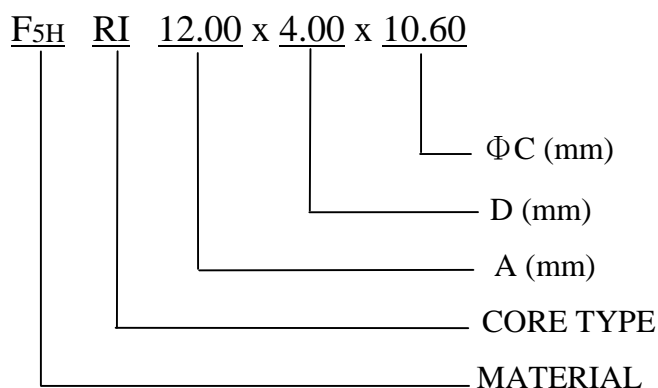
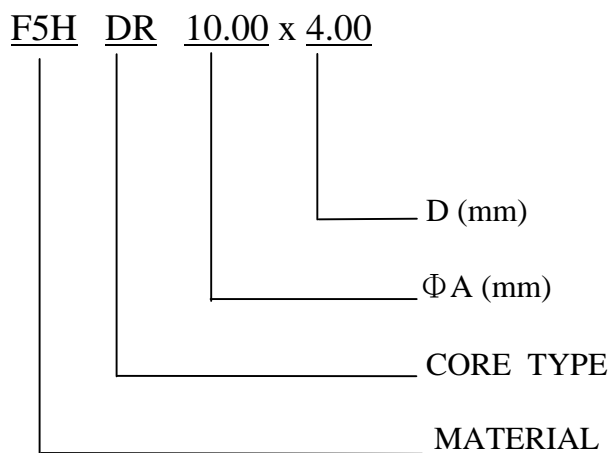

### 2. SHAPES

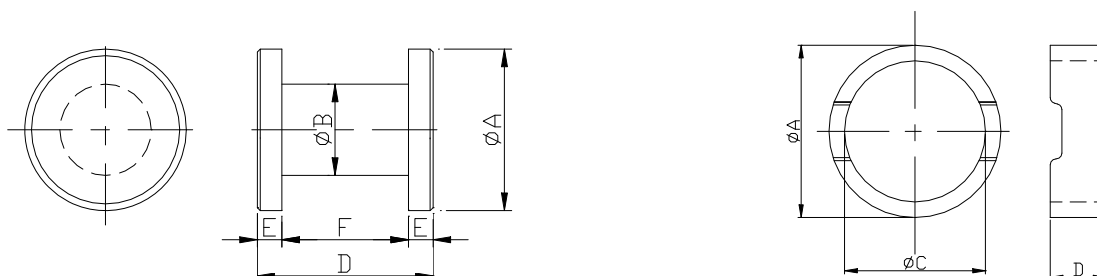

Fig.1

# DR&RI SERIES

## (SMD INDUCTOR CORES)

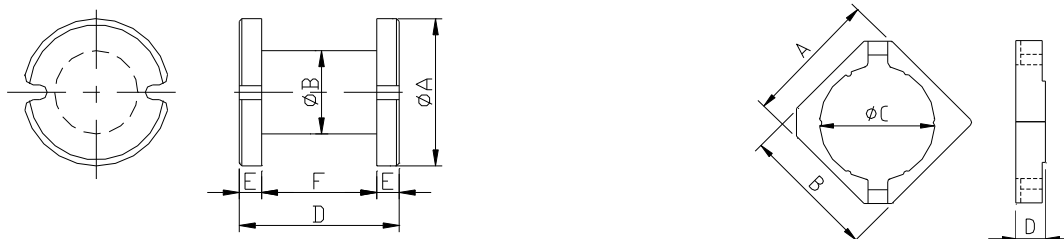

Fig.2

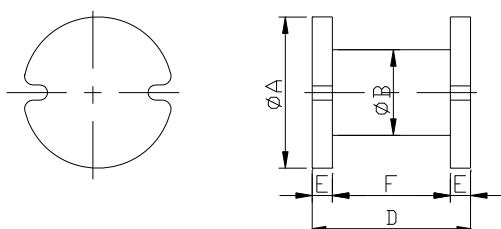

Fig.3

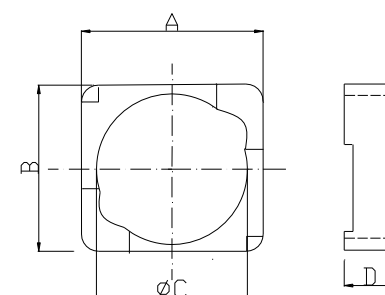

Fig.4

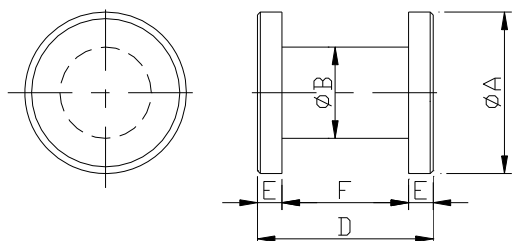

Fig.5

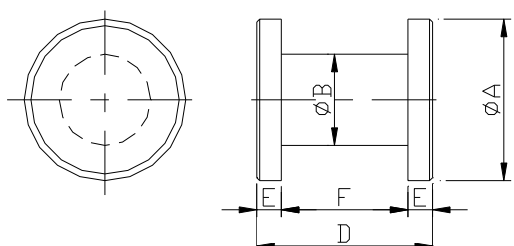
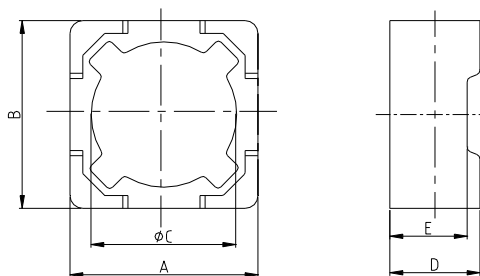
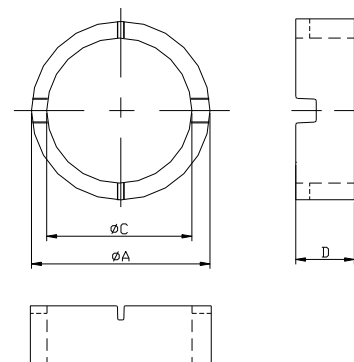

Fig.6



# DR&RI SERIES

## (SMD INDUCTOR CORES)

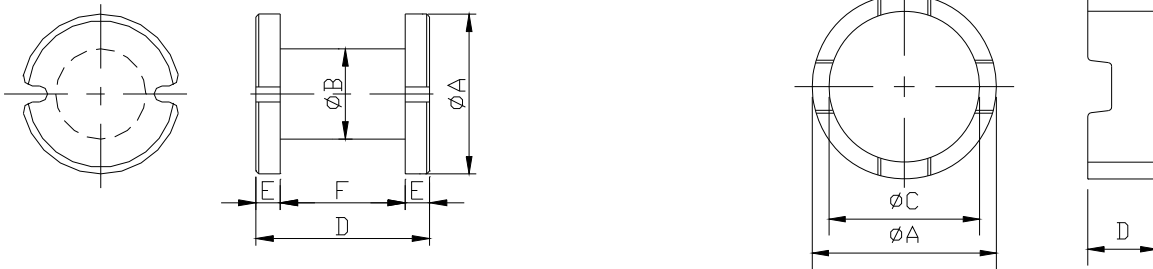

Fig.7

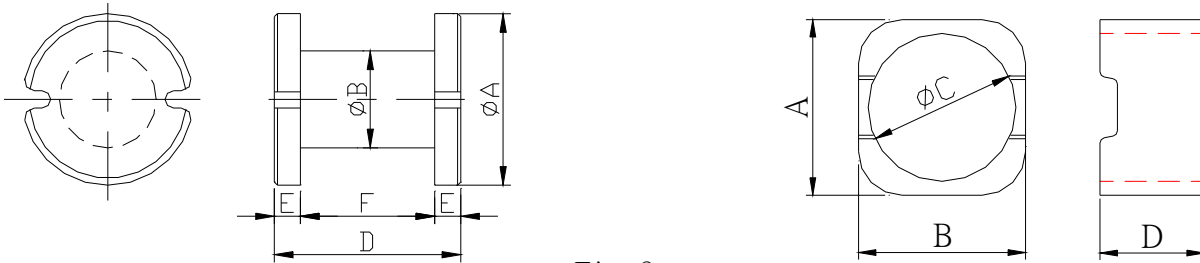

Fig.8

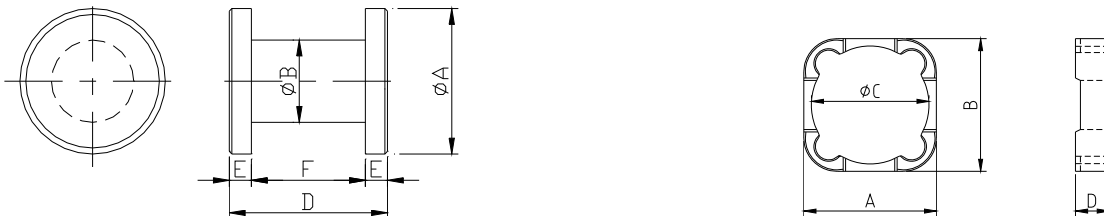

Fig.9

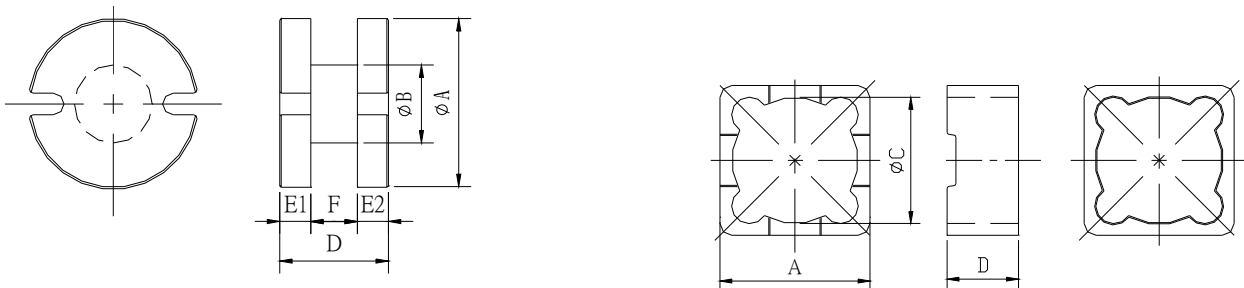

Fig.10

# DR&RI SERIES

## (SMD INDUCTOR CORES)

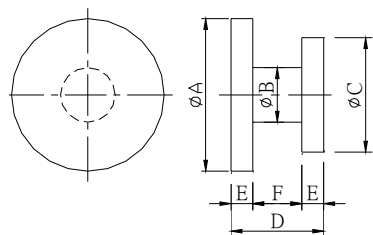

Fig.11

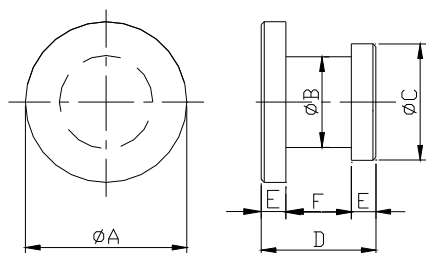
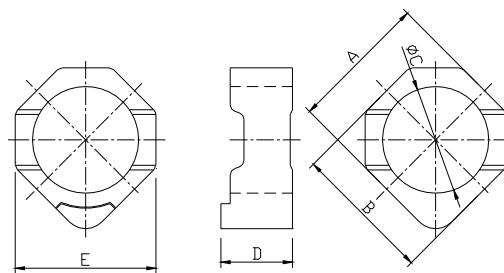

Fig.12

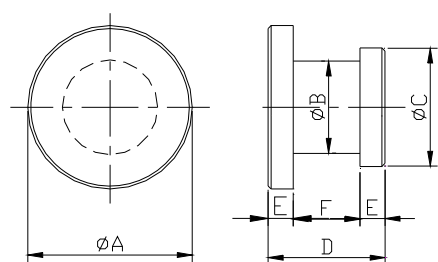
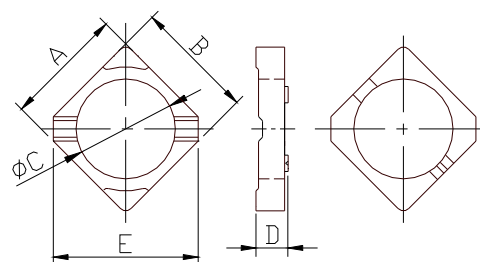

Fig.13

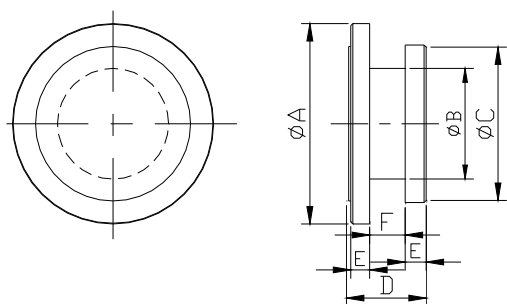
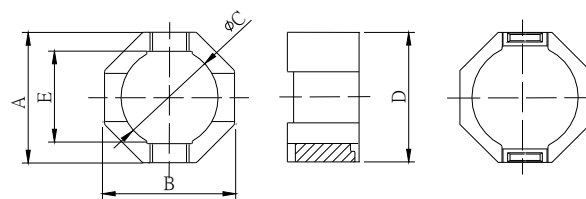

Fig.14

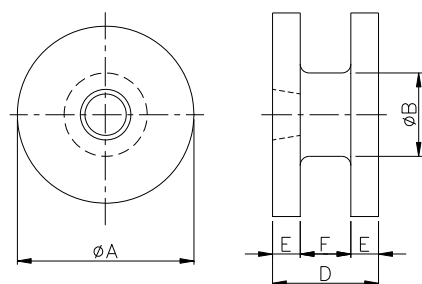
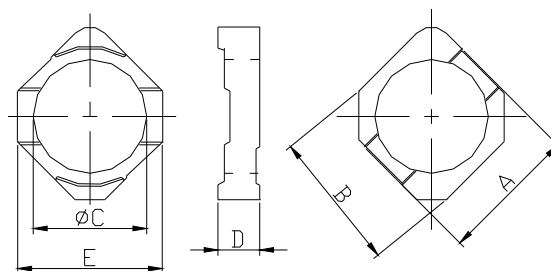
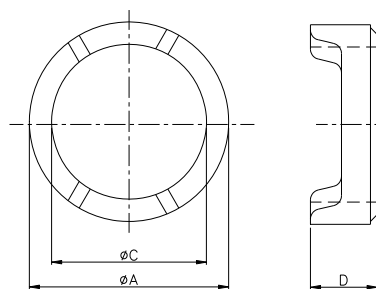

Fig.15



# DR&RI SERIES

## (SMD INDUCTOR CORES)

### 3.DIMENSIONS

Unit: mm

NO.	FERRICO PART NO.	Fig.	ΦA/A	ΦB/B	ΦC	D	E	F
1	___ DR 4.40x2.30(D29)	15	4.4±0.1	1.8±0.1		2.3±0.1	0.6±0.1	1.1±0.1
	___ RI 5.95x2.30x4.60		5.95±0.1		4.6±0.1	2.3±0.1		
2	___ DR 4.50x2.00	1	4.5 ±0.15	1.8 ±0.15		2.0 ±0.15	0.45 ±0.15	1.1 ±0.15
	___ RI 5.90x1.80x4.80		5.9 ±0.15		4.8 ±0.15	1.8 ±0.15		
3	___ DR 4.90x1.80(S)	2	4.9 ±0.2	1.9 ±0.2		1.8 ±0.2	0.4 REF.	1.0 ±0.15
	___ RI 6.00x1.70x5.10		6.0 ±0.2	6.0 ±0.2	5.1 ±0.2	1.7 ±0.2		
4	___ DR 4.00x4.50(S)	3	4.0 ± <sub>0.2</sub> <sup>0</sup>	2.0 ±0.15		4.5 ±0.2	1.25 REF.	2.0 ±0.2
	___ RI 6.20x4.40x4.40		6.2 ±0.2	5.9 ±0.2	4.4 ±0.2	4.4 ±0.2		
5	___ DR 5.30x3.60	4	5.3 ±0.1	2.8 ±0.1		3.6 ±0.15	0.65 REF.	2.3 ±0.15
	___ RI 7.30x3.50x5.65		7.3 ±0.2	7.3 ±0.2	5.65 ±0.1	3.5 ±0.15	3.0 ±0.1	
6	___ DR 5.00x5.60	5	5.0 ±0.15	2.6 ±0.15		5.6 ±0.15	0.7 REF.	4.2 ±0.15
	___ RI 7.30x5.60x5.40		7.3 ±0.15	7.3 ±0.15	5.4 ± <sub>0</sub> <sup>0.2</sup>	5.6 ±0.15		
7	___ DR 7.20x2.30(S)	6	7.2 ± <sub>0.15</sub> <sup>0</sup>	4.0 ±0.1		2.3 ±0.1	0.625±0.1	1.05 ±0.1
	___ RI 9.85x1.60x8.00		9.85 ±0.15		8.0 ±0.15	1.6 ±0.1		
8	___ DR 7.20x4.30(S)	7	7.2 ± <sub>0.15</sub> <sup>0</sup>	3.6 ±0.1		4.3 ±0.1	0.9±0.1	2.5 ±0.1
	___ RI 9.85x3.70x8.00		9.85 ±0.15		8.0 ±0.15	3.7 ±0.1		
9	___ DR 7.80x3.60	1	7.8 ±0.2	3.0 ±0.15		3.6 ±0.2	0.8±0.15	2.0 ±0.15
	___ RI 10.00x3.40x8.40		10.0±0.2		8.4 ±0.15	3.4 ±0.15		
10	___ DR 7.40x6.20(S)	8	7.4 ±0.15	3.5 ±0.15		6.2 ±0.15	1.35±0.15	3.5 ±0.15
	___ RI 10.10x6.00x8.60		10.1 ±0.2	9.6 ±0.2	8.6 ±0.15	6.0 ±0.15		
11	___ DR 9.80x2.70	1	9.8 ± <sub>0.15</sub> <sup>0.1</sup>	4.4 ±0.15		2.7 ±0.15	0.6 ±0.15	1.5 ±0.15
	___ RI 11.80x2.70x10.00		11.8 ±0.2		10.0 ± <sub>0.1</sub> <sup>0.15</sup>	2.7 ±0.15		
12	___ DR 10.00x4.00	9	10.0 ±0.2	5.0 ±0.2		4.0 ±0.2	1.0 REF.	2.0 ±0.2
	___ RI 12.00x4.00x10.60		12.0 ±0.2	12.0 ±0.2	10.6 ±0.2	4.0 ±0.2		
13	___ DR 10.00x5.00	9	10.0 ±0.2	4.5 ±0.2		5.0 ±0.2	1.0 REF.	3.0 ±0.2
	___ RI 12.00x5.00x10.60		12.0 ±0.2	12.0 ±0.2	10.6 ±0.2	5.0 ±0.2		
14	___ DR 10.00x7.00	9	10.0 ±0.2	6.2 ±0.2		7.0 ±0.2	1.0 REF.	5.0 ±0.2
	___ RI 12.00x7.00x10.60		12.0 ±0.2	12.0 ±0.2	10.6 ±0.2	7.0 ±0.2		
15	___ DR 10.00x8.70	9	10.0 ±0.2	6.0 ±0.2		8.7 ±0.2	1.6 REF.	5.5 ±0.2
	___ RI 12.00x8.70x10.60		12.0 ±0.2	12.0 ±0.2	10.6 ±0.2	8.7 ±0.2		
16	___ DR 9.50x5.00(S)	10	9.5 ± <sub>0.1</sub> <sup>0.15</sup>	5.0 ±0.1		5.0 ±0.15	0.95±0.15	3.0 ± <sub>0.1</sub> <sup>0.15</sup>
	___ RI 12.60x4.00x10.60		12.6 ±0.15		10.6 ±0.15	4.0 ±0.15		
17	___ DR 9.50x7.00(S)	10	9.5 ± <sub>0.1</sub> <sup>0.15</sup>	5.6 ±0.1		6.95 ±0.15	1.0±0.15	5.0 ±0.15
	___ RI 12.60x6.00x10.60		12.6 ±0.15		10.6 ±0.15	6.0 ±0.15		
18	___ DR 10.00x6.50	3	10.0 ±0.15	6.5 ±0.15		6.5 ±0.15	1.0 ±0.15	4.5 ±0.15
	___ RI 12.80x6.30x11.10		12.8 ±0.2		11.1 ±0.2	6.3 ±0.15		

# DR&RI SERIES

## (SMD INDUCTOR CORES)

### 3.DIMENSIONS

Unit: mm

NO.	FERRICO PART NO.	Fig.	$\Phi A/A$	$\Phi B/B$	$\Phi C$	D	E	F
19	___ DR 2.80x1.00(D3)	11	2.8 $\pm$ 0.10	0.85 $\pm$ 0.1	2.0 $\pm$ 0.1	1.0 $\pm$ 0.1	0.25 $\pm$ 0.1	0.5 $\pm$ 0.1
	___ RI 3.00x0.90x2.40		3.0 $\pm$ 0.15	3.0 $\pm$ 0.15	2.4 $\pm$ 0.1	0.9 $\pm$ 0.1	3.05 $\pm$ 0.1	
20	___ DR 2.80x1.20(D3)	11	2.8 $\pm$ 0.10	0.85 $\pm$ 0.1	2.0 $\pm$ 0.1	1.2 $\pm$ 0.1	0.35 $\pm$ 0.1	0.5 $\pm$ 0.1
	___ RI 3.00x1.10x2.40		3.0 $\pm$ 0.15	3.0 $\pm$ 0.15	2.4 $\pm$ 0.1	1.1 $\pm$ 0.1	3.05 $\pm$ 0.1	
21	___ DR 2.80x1.80(D3)	11	2.8 $\pm$ 0.10	1.0 $\pm$ 0.1	2.0 $\pm$ 0.1	1.8 $\pm$ 0.1	0.35 $\pm$ 0.1	1.1 $\pm$ 0.1
	___ RI 3.00x1.60x2.40		3.0 $\pm$ 0.15	3.0 $\pm$ 0.15	2.4 $\pm$ 0.1	1.6 $\pm$ 0.1	3.05 $\pm$ 0.1	
22	___ DR 3.50x1.50(D3)	11	3.5 $\pm$ 0.1	1.4 $\pm$ 0.1	2.6 $\pm$ 0.1	1.5 $\pm$ 0.1	0.3 $\pm$ 0.1	0.9 $\pm$ 0.1
	___ RI 3.80x1.35x3.08		3.8 $\pm$ 0.1	3.8 $\pm$ 0.1	3.08 $\pm$ 0.1	1.35 $\pm$ 0.1	4.17 $\pm$ 0.1	
23	___ DR 6.70x2.70(D3)	12	6.7 $\pm_{-0.3}^0$	2.3 $\pm$ 0.1	4.8 $\pm$ 0.1	2.7 $\pm$ 0.1	0.5 REF	1.7 $\pm$ 0.1
	___ RI 6.70x2.45x5.50		6.7 $\pm$ 0.2	6.7 $\pm$ 0.2	5.5 $\pm_{-0}^{0.2}$	2.45 $\pm$ 0.2	7.0 $\pm$ 0.2	
24	___ DR 8.00x2.70(D3)	13	8.0 $\pm$ 0.15	3.0 $\pm$ 0.1	5.8 $\pm$ 0.15	2.7 $\pm$ 0.1	0.6 $\pm$ 0.1	1.5 $\pm$ 0.1
	___ RI 8.00x2.10x6.50		8.0 $\pm$ 0.2	8.0 $\pm$ 0.2	6.5 $\pm$ 0.15	2.1 $\pm$ 0.1	6.3 $\pm$ 0.15	
25	___ DR 9.70x3.65(D3)	14	9.7 $\pm_{-0.25}^0$	4.8 $\pm$ 0.15	7.6 $\pm_{-0.25}^0$	3.65 $\pm$ 0.2	0.8 $\pm$ 0.1	1.95 $\pm$ 0.15
	___ RI 10.00x3.35x8.20		10.0 $\pm$ 0.3	10.0 $\pm$ 0.3	8.2 $\pm_{-0.1}^{0.2}$	3.35 $\pm_{-0.1}^{0.2}$	10.5 $\pm$ 0.2	

REMARK : OTHER SIZES ARE AVAILABLE UPON REQUEST

# DI2 SERIES

## (SMD CHIP INDUCTOR CORES)

### 1. ORDERING CODE

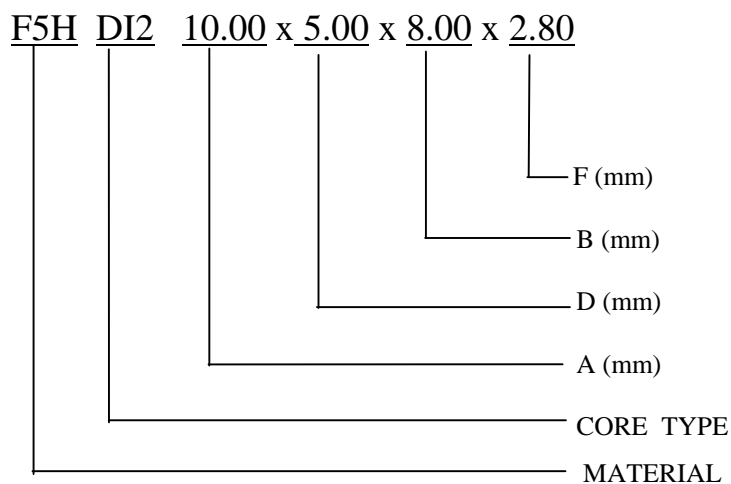

### 2. SHAPES

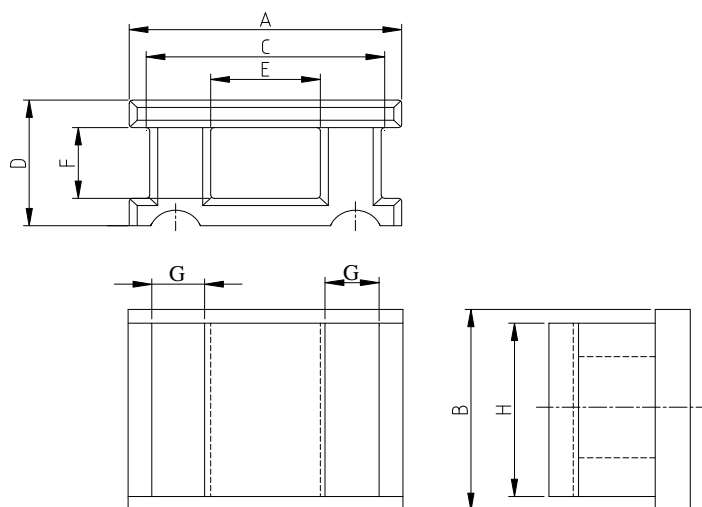

### 3. DIMENSIONS

Unit: mm

NO.	FERRICO PART NO.	A	B	C	D	E	F	G	H
1	DI2 4.50x1.80x3.20x0.50	4.5±0.2	3.2±0.2	3.1±0.2	1.8±0.2	1.5±0.15	0.5±0.1	1.25 REF.	2.6±0.2
2	DI2 5.00x5.00x8.50x2.60	5.0±0.3	8.5±0.4	3.9±0.4	5.0±0.3	1.7±0.2	2.6±0.2	0.6 REF.	7.9±0.2
3	DI2 7.50x3.00x6.00x1.70	7.5±0.4	6.0±0.3	6.1±0.3	3.0±0.2	3.0±0.2	1.7±0.1	1.5 REF.	5.3±0.3
4	DI2 10.00x5.00x8.00x2.80	10.0±0.5	8.0±0.4	8.5±0.4	5.0±0.3	4.0±0.3	2.8±0.3	1.5 REF.	6.9±0.3
5	DI2 12.00x4.60x10.00x3.00	12.0±0.5	10.0±0.4	9.8±0.4	4.6±0.3	3.0±0.2	1.8±0.2	2.0 REF.	8.5±0.3
6	DI2 12.00x6.00x10.00x3.20	12.0±0.5	10.0±0.4	10.2±0.4	6.0±0.3	4.33±0.3	3.2±0.2	1.6 REF.	8.8±0.3

REMARK : OTHER SIZES ARE AVAILABLE UPON REQUEST

# P SERIES



## 1.ORDERING CODE

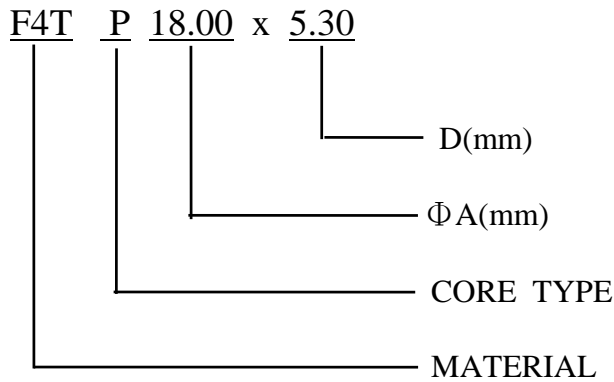

## 2. SHAPES

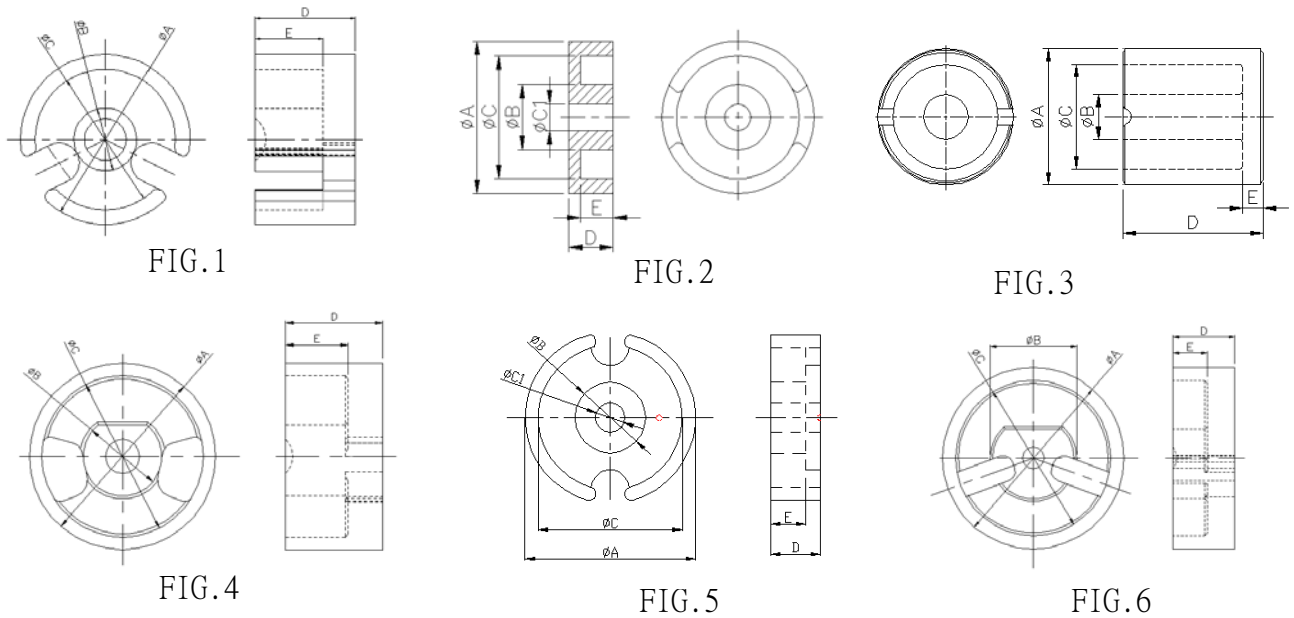

## 2.DIMENSIONS

Unit: mm

NO.	FERRICO PART NO.	Fig.	$\Phi$ A	$\Phi$ B	$\Phi$ C	$\Phi$ C1	D	E
1	___ P 5.30x4.00	1	$5.3^{+0.10}_{-0.15}$	$1.77 \pm 0.1$	$4.2 \pm 0.13$		$4.0 \pm 0.15$	$2.8^{+0.15}_{-0.05}$
2	___ P 5.70x1.70	2	$5.7^{+0}_{-0.15}$	$2.45^{+0}_{-0.1}$	$4.5^{+0.12}_{-0.03}$	$0.93^{+0.1}_{-0}$	$1.7^{+0}_{-0.1}$	$1.15^{+0.1}_{-0}$
3	___ P 8.00x4.70	1	$8.0 \pm 0.15$	$2.95 \pm 0.1$	$6.6 \pm 0.15$		$4.7 \pm 0.15$	$3.2 \pm 0.1$
4	___ P 9.10x9.40	3	$9.1 \pm 0.2$	$3.0^{+0.2}_{-0.1}$	$7.0^{+0.2}_{-0.1}$		$9.4 \pm 0.2$	$1.4 \pm 0.15$
5	___ P 13.40x7.00	4	$13.4^{+0.15}_{-0.25}$	$5.7 \pm 0.15$	$11.8^{+0}_{-0.4}$		$7.0 \pm 0.15$	$4.5 \pm 0.15$
6	___ P 18.00x5.30	5	$18.0^{+0.3}_{-0.4}$	$7.6^{+0}_{-0.3}$	$14.9^{+0.5}_{-0}$	$3.0^{+0.3}_{-0.1}$	$5.3^{+0.08}_{-0.22}$	$3.6^{+0.25}_{-0}$
7	___ P 25.00x8.50	6	$25.0^{+0.2}_{-0.4}$	$11.2 \pm 0.15$	$21.0^{+0.6}_{-0}$		$8.5 \pm 0.2$	$4.7 \pm 0.15$

REMARK : OTHER SIZES AND SHAPES ARE AVAILABLE UPON REQUEST .

# OTHER SERIES

## 1. SHAPES

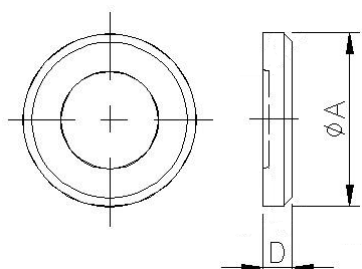

Fig.1

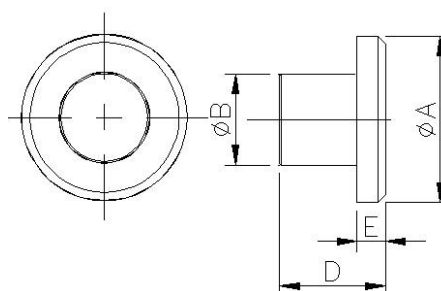

Fig.2

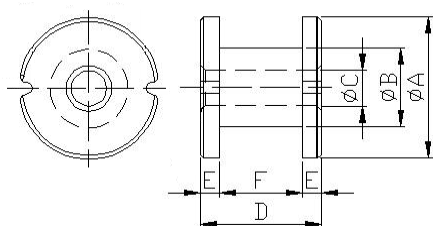

Fig.3

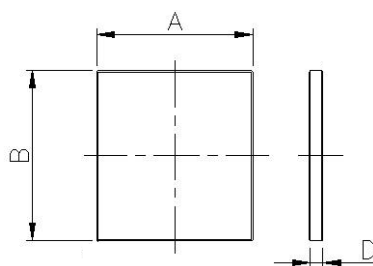

Fig.4

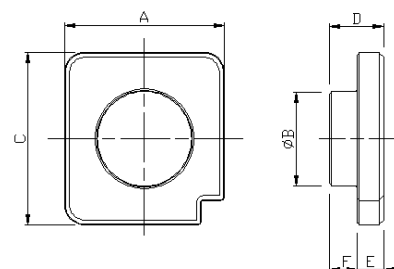

Fig.5

## 2. DIMENSIONS

Unit: mm

NO.	FERRICO PART NO.	Fig.	$\Phi A/A$	$\Phi B/B$	$\Phi C$	D	E	F
1	___DRP 21.00x3.60	1	21.0±0.3			3.6±0.2		
2	___ST 14.80x4.60	2	14.8±0.25	8.5±0.2		4.6±0.15	2.0±0.2	
3	___ST 21.00x13.40	2	21.0±0.3	11.5±0.25		13.4±0.3	3.6±0.2	
4	___ST 16.30x5.90	2	16.3±0.25	9.0±0.2		5.9±0.15	2.1±0.2	
5	___DRH 22.00x14.00 (S)	3	22.0±0.5	12.2±0.5	5.5±0.3	14.0±0.5	3.0±0.2	8.0±0.3
6	___DRH 22.00x17.00 (S)	3	22.0±0.5	12.2±0.5	5.5±0.3	17.0±0.5	3.0±0.2	11.0±0.3
7	___DRH 22.00x19.00 (S)	3	22.0±0.5	12.2±0.5	5.5±0.3	19.0±0.5	3.0±0.2	13.0±0.3
8	___DRH 22.00x25.00 (S)	3	22.0±0.5	10.2±0.5	5.5±0.3	25.0±0.5	3.0±0.2	19.0±0.3
9	___FP 24.00x1.80x22.00	4	24.0±0.5	22.0±0.5		1.8±0.15		
10	___FP 55.00x3.00x30.00	4	55.0±1.0	30.0±0.8		3.0±0.15		
11	___SS 24.00x6.60x23.00	5	24.0±0.4	11.5 <sup>0.15</sup> <sub>±0.20</sub>	23±0.3	6.6±0.2	3.2±0.2	3.4±0.2

REMARK : OTHER SIZES AND SHAPES ARE AVAILABLE UPON REQUEST







總公司：耕芯股份有限公司

臺灣省桃園縣楊梅市中山北路2段192號2樓A室 郵政編碼：326

TEL: 886-3-4828308 ( REP. ) FAX: 886-3-4828450

HEAD OFFICE: FERRICO CORPORATION

2F-A,NO.192,SEC.2,CHUNG-SHAN N.RD.,YANG-MEI,TAO-YUAN, TAIWAN,326

TEL: 886-3-4828308(REP.) FAX: 886-3-4828450

廣州廠：廣州耕芯電子有限公司

中國廣東省廣州市南沙區欖核鎮人民村人民路2號 郵政編碼：511480

TEL: 86-20-34872650 ( REP. ) FAX: 86-20-34872653

GUANG-ZHOU: GUANG ZHOU FERRICO ELECTRONICS CO., LTD.

NO.2, REN-MIN RD., REN-MIN VILLAGE, LAN-HE TOWN, NAN-SHA AREA,

GUANG-ZHOU CITY, GUANG-DONG, CHINA. POST CODE:511480

TEL: 86-20-34872650(REP.) FAX: 86-20-34872653

昆山廠：耕芯電子（昆山）有限公司

中國江蘇省昆山市千燈鎮善浦東路

KUN-SHAN: FERRICO ELECTRONICS (KUN SHAN) CO., LTD.

SHAN-PU E.RD, OIAN-DENG TOWN, KUN-SHAN CITY, JIANG-SU, CHINA.

E-mail: ferrico@ferrico.com

Website: <http://www.ferrico.com>

2024.01