

BAND SAWS 帶鋸機

HORIZONTAL BAND RESAW 橫式改料帶鋸機



SBR-228D-300

MODEL	型式	
Max. workpiece size	最大工作尺寸	400 x 400 mm
Dis. from upper blade to conveyor table	上鋸帶至輸送帶距離	20-250 mm
Dis. from lower blade to conveyor table	下鋸帶至輸送帶距離	6-200 mm
Width of conveyor belt	輸送帶寬度	280 mm
Saw wheel dia.	鋸輪直徑	750 mm
Feed speed	送料速度	0-22 m/min.
Saw wheel pressure	鋸輪壓力	42 kg
Sawblade specif (LxWxH)	鋸帶規格 (長x寬x高)	4900 x 25-38 x 0.89 mm
Saw wheel motor	鋸輪馬達	20 HP
Hydraulic system motor	油壓系統馬達	2 HP
Hydraulic pressure	油壓壓力	45 kg
Dust hood outlet dia.	吸塵罩口徑	100 mm
Elevation control	升降方式	Digital control
Packing dimensions	裝箱方式	(2 crates) 鐵板共2箱
Machine (LxWxH)	機身長 (長x寬x高)	1600 x 2300 x 2280 mm
Conveyor (LxWxH)	輸送帶長 (長x寬x高)	3000 x 650 x 850 mm
Net weight / Gross weight	淨重 / 毛重	2150 kg / 2450 kg

BAND SAW BLADE SHARPENER 精密磨鋸機

- The wet grinding feature assures extremely fine finish on teeth surfaces and greatly extends cutting period of sawblade.
- Grinding amount adjustment is accurately indicated by dial gauges.
- Variable grinding speed is controlled by frequency inverter.
- The micro-computer control provides automatic and humanified operations.
- Electronic parts and circuit design meet CE standards.
- Electronic parts feature multiple interference resistances and protections.

- 採用濕式研磨，確保研磨後的齒面光滑度，有效延長鋸齒的鋸切時數。
- 研磨量的調整，全部使用百分表顯示。
- 研磨速度的調整，採用無段變頻設計。
- 本機器採用微電腦可程式控制器，操控自動化、人性化。
- 電器零件與線路設計，完全符合歐盟CE安全規範。
- 電器多重抗干擾與保護措施。



SG-25

MODEL	型式	
Motor	馬力	1 HP + 1/4 HP + 1/8 HP
Blade thickness	鋸片厚度	<2 mm
Blade width	鋸片寬度	35-40 mm
Blade length	鋸片長度	Unlimited (無限)
Tooth pitch	齒距	<20 mm
Tooth height	齒高	<5 mm
Front rake angle	前傾角	5-15 Degrees
Working speed	研磨速度	1.4-6.4 Sec./tooth

THIN CUTTING FRAME SAW

薄片框鋸機

HIGH PRECISION HIGH EFFICIENCY

- Single, two, or multiple wood cutting as desired.
- Reduces material loss to a minimum.
- Extremely fine surface effect.



SAWBLADE AIR BLAST

The air blast device provides cooling to the sawblades for extending blades service life. In addition, the device also can remove saw dust existed in blade teeth ensuring high quality cutting at all times.

STABLE CUTTING

The wood to be cut is supported steadily, ensuring high stability of cutting.

鋸帶吹氣裝置

此吹氣裝置除了提供鋸帶之冷卻功能延長鋸帶使用壽命，並且可隨時清除鋸齒上的木屑確保鋸切品質。

加工穩定

木料之支柱穩固，確保加工時最佳之穩定性。



FINE SURFACE

Extremely fine surface effect after cutting which permits direct glue jointing for saving 0.15mm sanding tolerance.

精緻的表面

鋸切面極為光滑鋸切後可直接膠合節省0.15mm之砂磨預留量。



SAVING COST

The frame saw reduces material loss to a minimum. It saves 20% wood material when comparing with that by a conventional machining method.

節省成本

框鋸之鋸路損失極少相較於傳統加工方式可節省20%之木料。



ACCURATE THICKNESS OF CUT

High accuracy thickness of cut is $\pm 0.1\text{mm}$. No gapping problem on the cut surface.

鋸切高精度

鋸切厚度公差為 $\pm 0.1\text{mm}$ 而鋸切面不會產生接縫問題。

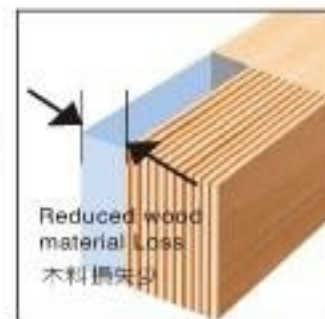

Wood cutting performed by the frame saw may reduce material loss to a minimum for saving production cost.

採用框鋸機鋸切可將木料損失大幅降低節省成本。

MODEL

型式

SF-15

Motor	馬力	11 Kw (15 HP)
Feed speed	送料速度	0.3-1.7 M/min.
Frame stroke	鋸框行程	210 mm
Stroke number per minute	鋸框轉速 (每分鐘)	450 rpm
Height range of cut	鋸切高度	30-200 mm
Wood height difference	容許木料高度差	$\pm 0.5\text{ mm}$
Width of cut (side guide fence)	鋸切寬度 (側導板)	60-150 mm
Width of cut (center guide fence)	鋸切寬度 (中心導板)	2 x 30-70 mm
Width of cut (channel type)	鋸切寬度 (多導槽型)	2-4 x 20-65 mm
Minimum block length	最短木料長度	300 mm
Slice thickness	最小薄片厚度	$> 2.0\text{ mm}$
Cutting accuracy (under 120mm)	鋸切精度 (小於120 mm)	$\pm 0.1\text{ mm}$
Cutting accuracy (over 120mm)	鋸切精度 (大於120 mm)	$\pm 0.15\text{ mm}$
Cutting loss	鋸路損失	1.1~1.4 mm
Approx saw blade number	容許最多鋸片數	$< 22\text{ pc}$
Maximum saw blade life	鋸帶壽命 (小時)	4~24 hour
Net weight	淨重	2350 Kg
Gross weight	毛重	2600 Kg
Machine dimensions (L x W x H)	機械尺寸 (長x寬x高)	3600 x 800 x 1900 mm
Packing dimensions (L x W x H)	裝箱尺寸 (長x寬x高)	2740 x 1200 x 2210 mm

BAND SAWS 帶鋸機

AUTO BAND SAWBLADE SHARPENER 自動磨鋸機

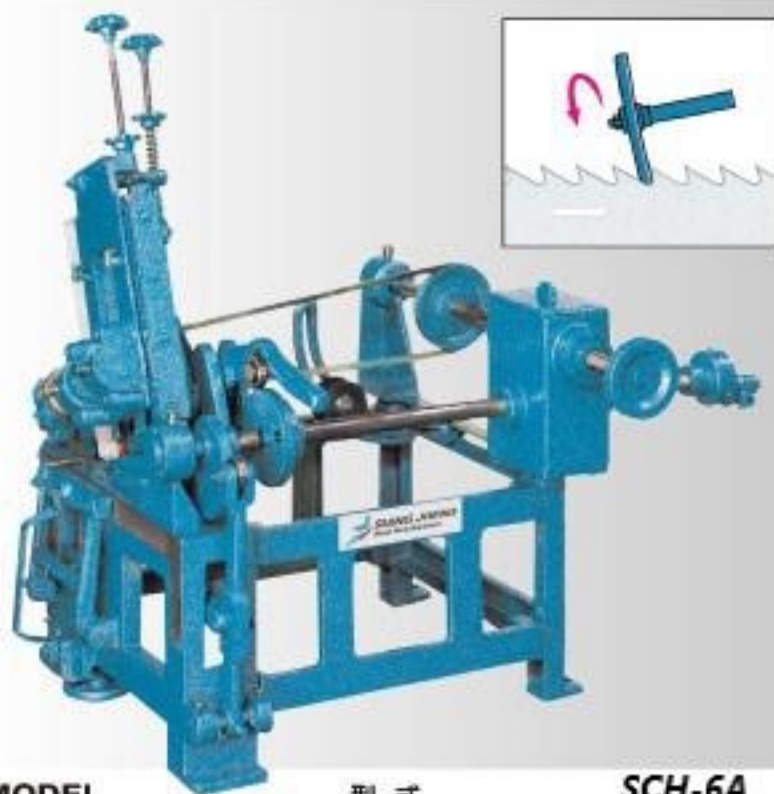

MODEL	型式	SCH-6A
Max blade width	最大磨鋸帶寬	6"
Grinding wheel size	砂輪尺寸	8" / 10"
Motor	馬達	1 HP
Net weight	淨重	170 kgs
Gross weight	毛重	240 kgs
Machine dimensions (LxWxH)	機械尺寸 (長x寬x高)	38" x 34-1/2" x 37"
Packing dimensions (LxWxH)	裝箱尺寸 (長x寬x高)	42" x 38-1/2" x 37"

BAND SAWBLADE STRETCHER 帶鋸伸鋸機



MODEL	型式	SCH-6S
Max.sawblade width	最大伸鋸寬度	6"
Motor	馬達	1 HP
Net weight	淨重	80 kgs
Gross weight	毛重	150 kgs
Machine dimensions (LxWxH)	機械尺寸 (長x寬x高)	22" x 12" x 18"
Packing dimensions (LxWxH)	裝箱尺寸 (長x寬x高)	26" x 16" x 24"

BAND SAWBLADE BRAZING CLAMP 接鋸機 (焊接鋸片)

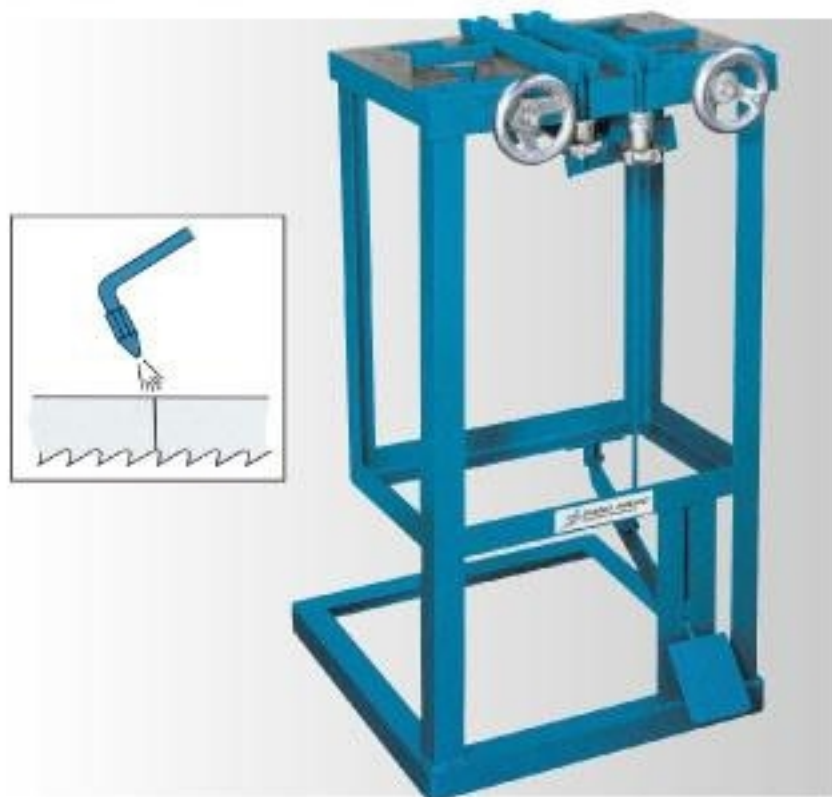

MODEL	型式	SCH-6W
Welding width of blade	接鋸寬度	1/2"-6"
Net weight	淨重	60 kgs
Gross weight	毛重	130 kgs
Machine dimensions (LxWxH)	機械尺寸 (長x寬x高)	19" x 22" x 36"
Packing dimensions (LxWxH)	裝箱尺寸 (長x寬x高)	20" x 23" x 37"

BAND SAWBLADE KNOCKING MACHINE 帶鋸打鋸機



MODEL	型式	SCH-5A
Max.sawblade width	最大鋸帶寬度	1/2"-5"
Net weight	淨重	50 kgs
Gross weight	毛重	70 kgs
Machine dimensions (LxWxH)	機械尺寸 (長x寬x高)	18" x 20" x 48"
Packing dimensions (LxWxH)	裝箱尺寸 (長x寬x高)	22" x 24" x 52"

BAND SAWS 帶鋸機

LOG BAND MILL 高速製材機



MODEL	型式	SYT-28TB	SYT-30TB	SYT-36TB	SYT-38TB
Wheel diameter & width	鋸輪直徑和寬 (mm)	710 x 90	760 x 90	710 x 90	960 x 90, 960 x 114
Saw blade size 使用鋸片規格	Width (mm) 寬	100	100	100	100-127
	Length (mm) 長	5220-5290	5700-5770	6310-6350	6850-6950
	Thickness (mm) 厚	20-22#	20-22#	20-22#	19-22#
Max. center cutting diameter	中心線割最大直徑	620 mm	660 mm	750 mm	800 mm
Distance between saw & frame	鋸片至機座距離	355 mm	370 mm	430 mm	455 mm
Max. distance between saw & gauge	鋸片至尺規板最大距離	250 mm	270 mm	290 mm	305 mm
Wheel allowable speed (R.P.M.)	鋸輪容許回轉速 (R.P.M.)	600-700	600-700	700-900	700-900
Belt wheel size	皮帶輪規格	280 x 70 mm	280 x 70 mm	305 x 90 mm	305 x 90 mm
Motor	使用動力	5-10 HP	5-10 HP	7.5-10 HP	10-15 HP
Net weight	淨重	900 kg	900 kg	1200 kg	1400 kg
Gross weight	毛重	1200 kg	1200 kg	1500 kg	1850 kg

BAND SAW 帶鋸機



MODEL	型式	SLY-26	SLY-28
Wheel diameter	鋸輪直徑	26"	28"
Motor power	馬力	2 HP	3 HP
Sawblade specif	鋸帶尺寸	183" x 2"	187.5" x 3"
Workpiece size	工作尺寸	14" x 12"	14" x 14"
Spindle speed	鋸輪迴轉速	650-700 rpm	500-600 rpm
Table area	工作台面積	23" x 27.5" kgs	23" x 27.5" kgs
Machine dimensions (L x W x H)	機械尺寸 (長 x 寬 x 高)	48" x 29" x 78"	48" x 29" x 81"
Packing dimensions (L x W x H)	裝箱尺寸 (長 x 寬 x 高)	52.5" x 31" x 84"	52.5" x 31" x 88"
Net weight	淨重	350 kgs	420 kgs
Gross weight	毛重	450 kgs	520 kgs

BAND SAWS 帶鋸機

JIG SAW 電動線鋸機



MODEL	型式	SHS-108	SHS-208
Throat depth	切削中心至機身前距離	650 mm	650 mm
Maximum thickness of cut	加工厚度	100 mm	100 mm
Table surface size	定盤面積	375 x 485 mm	485 x 500 mm
Jig sawblade length	鋸條長度	310 mm	310 mm
Motor	馬達	1/2 HP	1 HP
Speed	轉速	1000	1500
Net weight	淨重	180 kg	280 kg
Gross weight	毛重	260 kg	360 kg
Machine dimensions (L x W x H) mm	機身尺寸(長x寬x高)	1030 x 525 x 1170	1050 x 650 x 1230
Packing dimensions (L x W x H) mm	裝箱尺寸(長x寬x高)	1105 x 600 x 1268	1125 x 725 x 1370

VERTICAL BAND RESAW 再鋸機

TF-700/TF-900 Automatic system

- Hydraulic drives feed rollers. (Variable)
- Guide rollers are driven by a combination system of pneumatic and hydraulic.
- Automatic sawblade cooling system.



MODEL	型式	STF-700 Two feed rollers	STF-900 Two feed rollers
Cutting capacity	縱切能力	H375 x W375 mm	H530 x W420 mm
Min. cutting thickness	最小加工厚度	3 mm	3 mm
Distance from fence to blade	導板至鋸帶距離	185 mm	230 mm
Distance from feed roller to blade	送料輪至鋸帶距離	190 mm	190 mm
Height from the floor to table	台面離地高度	835 mm	975 mm
Wheel diameter	縱輪直徑	28"	36"
Wheel width	縱輪寬度	3-1/2"	3-1/2"
Width of blade	鋸帶寬度	4"	4"
Length of blade	鋸帶長度	4850 mm	5760 mm
Feed speed (Variable)	送料速度(無段)	0-30 M/min	0-30 M/min
Wheel drive motor	縱輪驅動馬達	20 HP	30 HP
Hydraulic pump motor	液壓泵馬達	2 HP	2 HP
Net weight / Gross weight	淨重 / 毛重	1700 kgs / 1900 kgs	2800 kgs / 3000 kgs
Packing dimensions (LxWxH)	裝箱尺寸(長x寬x高)	230 x 135 x 225 cm	273 x 142 x 255 cm

HORIZONTAL BAND RESAW 橫式改料帶鋸機



MODEL	型式	SHBR-300	SHBR-400
Maximum cutting capacity (WxH)	最大木材截面(寬x高)	12" x 10" (300 x 250 mm)	16-1/2" x 16-1/8" (420 x 410 mm)
Distance from blade to conveyor	鋸帶至送料帶距離		1/4" x 10-5/8" (5-270 mm)
Minimum cut piece	可切薄最小厚度	2 mm	5 mm
Saw wheel diameter	鋸輪直徑	24" x 2 (600 mm x 2)	32" x 2 (800 mm x 2)
Sawblade length	鋸帶長度	183-7/8" - 184-1/4" (4670-4680 mm)	5750 - 5760 mm
Sawblade width	鋸帶寬度	1-1/4" (32 mm)	2" (50 mm)
Sawblade speed	鋸帶轉速	600 F.P.M.	6150 F.P.M.
Conveyor belt sizes (WxL)	送料帶尺寸(寬x長)	10-5/8" x 165-1/2" (270 x 4200 mm)	16" x 165-1/2" (400 x 4200 mm)
Feed speed (variable)	送料速度(可調轉)	0-70 m/min	0-40 m/min
Feed conveyor tilt	送料台斜角	0° - 30°	
Conveyor height from floor	送料台高度	40" (1016 mm)	40" (1016 mm)
Return conveyor size (LxWxH)	回料輸送機尺寸(長x寬x高)		100-3/8" x 24-3/4" x 32 1/2" (2550 x 630 x 825 mm)
Return conveyor motor	回料輸送機馬達		1HP
Inverter motor	變頻馬達		2 HP
Saw wheel motor	鋸輪馬達	20 HP	30 HP (40 HP optional)
Blade lift motor	鋸帶升降馬達	1/2 HP	1/2 HP
Dust hood outlet diameter	排屑口直徑	ø4"	100 mm x 2 (4" x 2)
Machine dimensions (LxWxH)	機身尺寸(長x寬x高)	88" x 85-3/4" x 74" (2235 x 2180 x 1880 mm)	3250mm x 3300mm x 2000 mm
Packing dimensions (LxWxH)	裝箱尺寸(長x寬x高)	90-1/2" x 88" x 80" (2300 x 2235 x 2032 mm)	2750mm x 2250mm x 2200 mm
Net weight / Gross weight	淨重 / 毛重	1200 kgs / 1400 kgs	1960 kgs / 2160 kgs

HORIZONTAL BAND RESAW 橫式改料帶鋸機



MODEL	型式	SBR-750AD	SBR-750A	SBR-750T
Max. workpiece size	最大工作尺寸	300 x 300 mm	300 x 300 mm	300 x 300 mm
Dis. from blade to conveyor table	鋸帶至輸送帶距離	6-200 mm	4-200 mm	4-200 mm
Width of conveyor belt	輸送帶寬度	280 mm	280 mm	280 mm
Saw wheel dia	鋸輪直徑	750 mm	750 mm	750 mm
Feed speed	送料速度	0-22 m/min.	0-22 m/min.	0-20 m/min.
Saw wheel pressure	鋸輪壓力	40 kg	40 kg	45 kg
Sawblade specif. (LxWxH)	鋸帶規格(長x寬x高)	4300 x 25-38 x 0.89 mm	4800 x 25-38 x 0.89 mm	4800 x 25-38 x 0.89 mm
Saw wheel motor	鋸輪馬達	20 HP	20 HP	20 HP
Hydraulic system motor	油壓系統馬達	2 HP	2 HP	1 HP
Hydraulic pressure	油壓壓力	45 kg	45 kg	-
Dust hood outlet dia	吸塵罩口徑	100 mm	100 mm	100 mm
Elevation control	升降方式	Digital control	Hydraulic	Manual
Packing dimensions	裝箱方式	(2 crates) 底板共分2箱	(2 crates) 底板共分2箱	(2 crates) 底板共分2箱
Machine (LxWxH)	機身尺寸(長x寬x高)	2300 x 1650 x 2100 mm	2300 x 1520 x 2100 mm	1520 x 2300 x 1800 mm
Conveyor (LxWxH)	輸送帶尺寸(長x寬x高)	2900 x 680 x 800 mm	2900 x 680 x 800 mm	2900 x 750 x 850 mm
Net weight / Gross weight	淨重 / 毛重	1450 kg / 1850 kg	1400 kg / 1800 kg	1200 kg / 1600 kg