

## SPECIFICATION



 **16 t**

 **33.5 m**

 **36 m**

# STC160T

SANY TRUCK CRANE

台灣經銷商：宜宗重機械有限公司

宏江重機械企業有限公司

展場地址：台中市后里區三線路18-16號

展場電話：04-25590268 / 0975-193161

QUALITY CHANGES THE WORLD

[www.sanyglobal.com](http://www.sanyglobal.com)

# SANY CRANE

BETTER WORLD, BETTER SANY CRANE

SANY CRANE is one of the core business units in SANY Group, specializing in the development and manufacturing of high-end wheeled cranes, crawler cranes and tower cranes.

三一集團旗下核心事業部，從事高端輪式起重機、履帶起重機、塔式起重機系列產品的研發製造。

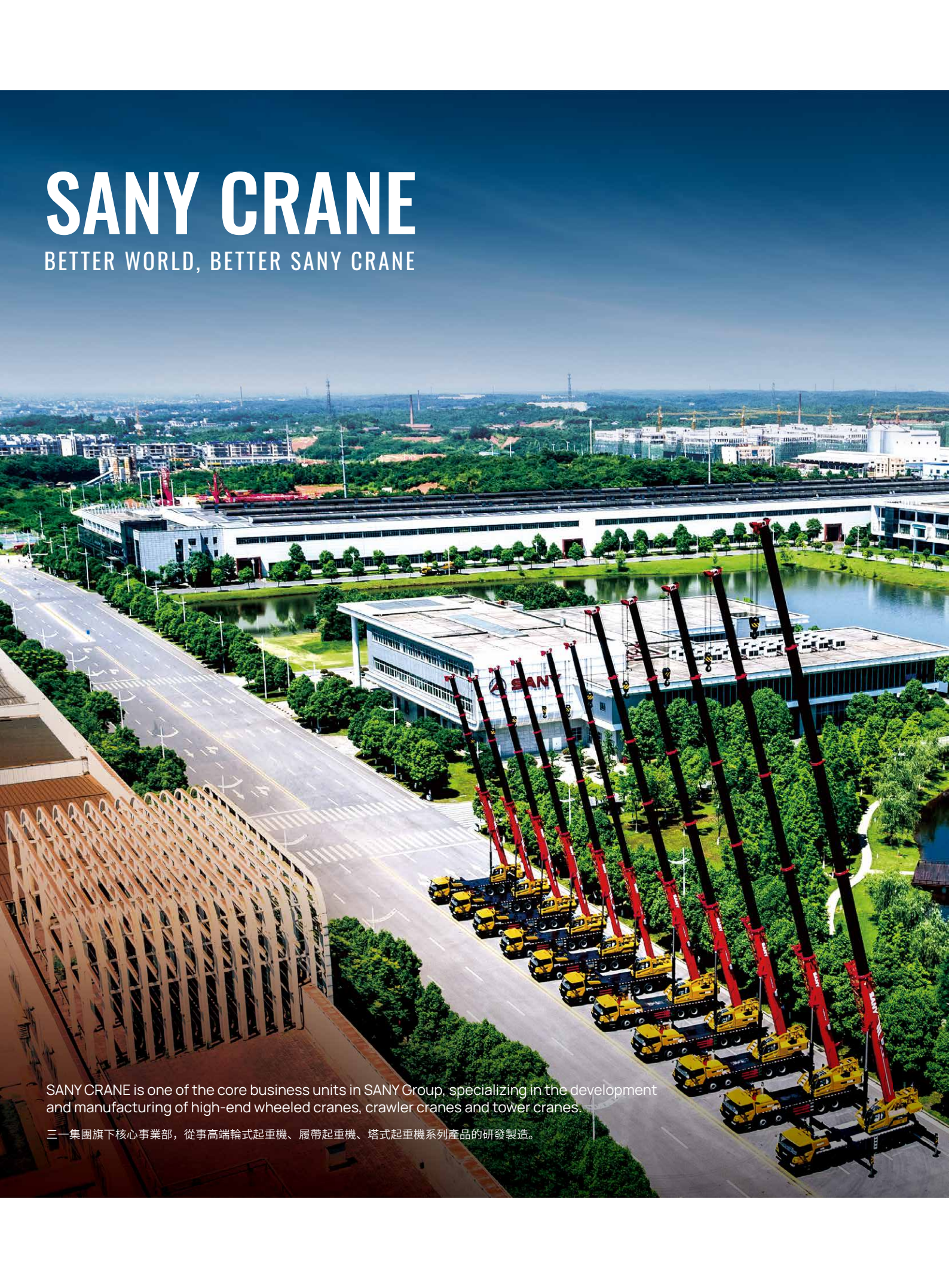



# CONTENTS

## 目錄

---

Highlights 整機亮點	▶ 04
--------------------	------

---

Overall Dimensions 整機尺寸	▶ 06
----------------------------	------

---

Technical Specifications 整機參數	▶ 07
----------------------------------	------

---

Machine Introduction 整機介紹	▶ 09
------------------------------	------

---

Working Conditions & Code Description 工況組合及工況代碼說明	▶ 11
T	12
TJ	13

---

Icon Description 圖標說明	▶ 14
--------------------------	------

---

SANY Overseas Service 三一海外服務	▶ 15
---------------------------------	------

## HIGHLIGHTS

### 整機亮點

## Compact and Flexible All-New Platform

### 緊湊靈活 全新平臺

Off-road G-class chassis, short and compact, it offers the industry's smallest steering radius of 7m, overall vehicle length of 10.66m, and height of 3.4m. It is highly maneuverable and is the perfect tool for lifting operations in narrow spaces.

Innovative front outrigger structure, with a span of 6.7m longitudinally and 6.2m laterally, it offers optimal matching for lateral and rear spans, allowing for 360° operations without the need for a center front stabilizer, convenient and efficient. Equipped with a 2t large counterweight. Capable of full boom extension and horizontal positioning for easy greasing.

19.1t crane weight, the front and rear axle loads are optimally balanced. The self-developed special chassis and integrated frame offer superior bending and torsion resistance, minimizing deformation under load.

Standard 315/80R22.5 tires, and the vehicle can reach a maximum speed of 90 km/h and maximum gradeability of 45%.

越野G類底盤，超短緊湊，行業最小轉彎半徑7m，10.66m短車長，3.4m低車高，機動靈活，狹窄場地中的吊裝神器；  
創新支腿前置結構，跨距縱向6.7m×橫向6.2m，最佳側後方跨距匹配，可全方位360°作業，無需第五支腿，方便快捷，搭配2.0t大配重，可全伸臂臥平打黃油；  
整車質量19.1t，前後軸荷匹配最佳，自製專用底盤，一體式車架抗彎抗扭更強勁，吊載變形小；  
標配315/80R22.5輪胎，最高車速90Km/h，最大爬坡度45%。

Truck Crane  
**STC160T / 16t Lifting Capacity**

## Leading Control Pilot Control System

操控領先 先導操控系統

10ml/r piston pump + load-sensing system, powerful and stable at low speeds, with a 20% increase in efficiency.

Pressure-adaptive telescoping technology, enhances boom telescoping stability, minimizing impact when retracting and extending the boom.

Standard pilot hydraulic control system, offers intuitive operation, significantly reducing operator fatigue.

110ml/r 柱塞泵+負載敏感系統，動力強勁低速穩定，效率 $\uparrow$ 20%；  
壓力自適應伸縮技術伸縮技術，大臂伸縮穩定性升級，縮臂啟動到位沖擊小；  
標配先導液壓操控系統，隨心而動，極大降低操作疲勞度。



# OVERALL DIMENSIONS

## 整機尺寸

Unit: mm

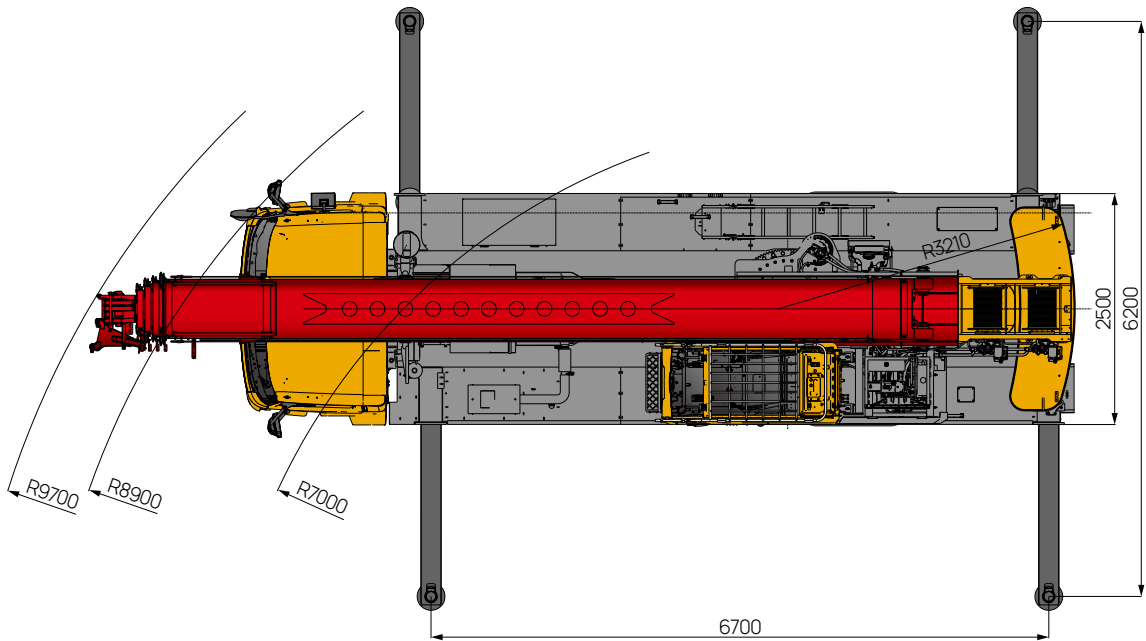
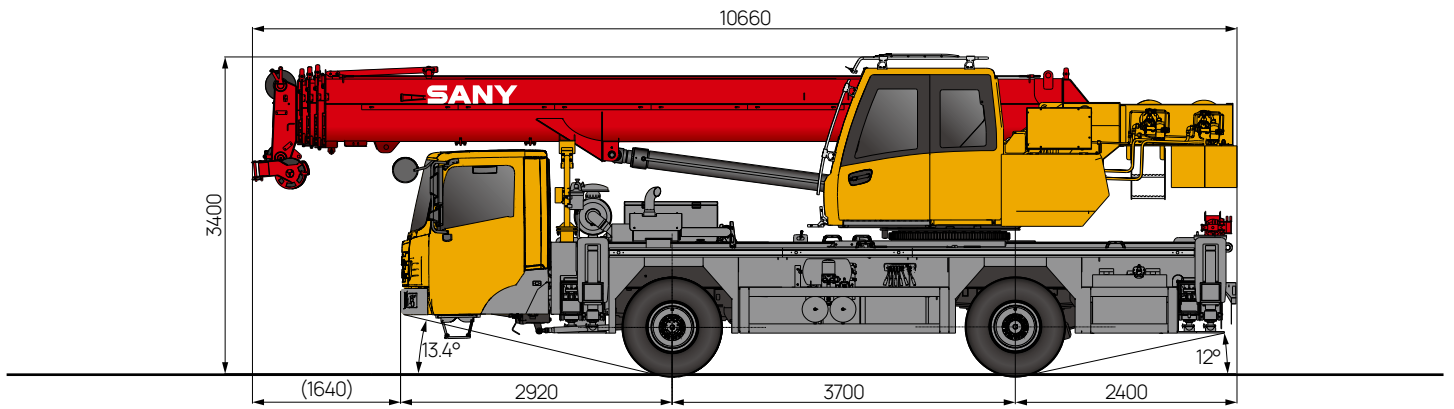

# TECHNICAL SPECIFICATIONS





## 整機參數

CATEGORY 類型	ITEM 項目	UNIT 單位	VALUE 參數	
CAPACITY 額定起重量	Max. lifting capacity 最大起重量	t	16	
WEIGHT 重量參數	Gross weight 整機總質量	kg	19100	
	Axle load 一軸負荷 載荷	kg	7900	
	Axles 2 二軸負荷	kg	11200	
POWER (CHASSIS) 發動機參數(下車)	Engine model 發動機型號(排放標準)	-	YCS04220-30(Euro III) 玉柴YCS04220-30(歐三)	
	Max. engine power 發動機最大功率	kW/rpm	162/2300	
	Max. engine torque 發動機最大輸出扭矩	N·m/rpm	850/(1200~1600)	
DIMENSIONS 尺寸參數	Overall length 整機全長	mm	10660	
	Overall width 整機全寬	mm	2500	
	Overall height 整機全高	mm	3400	
	Axle base 軸距	mm	3700	
TRAVEL 行駛參數	Max. travel speed 最高行駛速度	km/h	90	
	Min.steering radius 最小轉彎半徑	m	7	
	Min.ground clearance 最小離地間隙	mm	250	
	Approach angle 接近角	o	≥13	
	Departure angle 離去角	o	≥12	
	Braking distance (vehicle speed 30km/h) 製動距離(車速為30km/h)	m	≤10	
	Max.gradeability 最大爬坡度	-	45%	
	Fuel consumption per 100km 每100公裏油耗	l	≤17	
MAIN PERFORMANCE 主要性能參數	Min.rated lifting radius 最小額定幅度	m	3	
	Tail slewing radius 轉臺尾部回轉半徑	m	3.2	
	Max.lifting moment 最大起重力矩	Basic boom 基本臂	kN·m	563.5
		Full-extension boom 全伸主臂	kN·m	410
		Longest boom + fixed jib combination 最長主臂+副臂組合	kN·m	104
	Boom length 臂長	Basic boom 基本臂	m	8.7
		Full-extension boom 全伸主臂	m	33.5
		Longest boom + fixed jib combination 最長主臂+副臂組合	m	35.5
	Max.lifting height 最大起重高度	Basic boom 基本臂	m	9.2
		Full-extension boom 全伸主臂	m	34
		Longest boom + fixed jib combination 最長主臂+副臂組合	m	36
	Outrigger span (Longitudinal × Transverse) 支腿跨距(縱×橫)	m	6.2×6.7	
Jib offset 副臂安裝角度	°	0, 15, 30		
AIRCONDITIONER 空調	In operator's cab 上車空調	-	Heating & cooling 製冷、製熱	
	In driver's cab 下車空調	-	Heating & cooling 製冷、製熱	

# TECHNICAL SPECIFICATIONS













## 整機參數

### ■ Hook 吊鉤

				
12t (Single hook 單鉤)	3	7	110	●
3	0	1	52	●

● Standard 標配 ○ Optional 選配

### ■ Operations 主要動作參數

				
	0~125m/min	Φ12mm	145m	2.1t
	0~125m/min	Φ12mm	80m	2.1t
	0-2.5r/min			
	50s/75s(0~78°)			
	25s/40s(8.7m~33.5m)			
	25s (extension 伸) / 25s (Retraction 縮)			
	15s (extension 伸) / 15s (Retraction 縮)			

# MACHINE INTRODUCTION

## 整機介紹

### Carrier 下車

#### Driver's cab 駕駛室

- The frame is made from corrosion-resistant steel plates. The dashboard inside the cabin is ergonomically designed and includes a large curved front window, electronic simulation instruments.
- 整體框架由耐腐蝕鋼板製成，駕駛室內儀表盤設計符合人體工程學原理，配置了大圓弧整體式前窗、電子模擬儀表盤、冷暖空調。

#### Carrier frame 車架

- The vehicle features a classic SANY hybrid frame, welded from high-strength steel plates. Its torsion-resistant box structure offers greater load capacity and stability, while the overall power and hydraulic systems are arranged more compactly.
- 采用三一經典混合型車架，由高強鋼板焊接而成，防扭轉的箱形結構承載能力更強，穩定性更好，整體動力及液壓系統布置更緊湊。

#### Axle 車橋

- Press welding process strengthens the axle cover.
- 沖焊橋殼工藝，承載能力更強。

#### Chassis engine 底盤發動機

- YUCHAI diesel engine, Euro III emission, fuel reservoir capacity 165L.
- 玉柴柴油發動機；排放符合歐三標準；燃油箱有效容積165L。

#### Transmission 變速箱

- 8-speed manual transmission with synchronizer.
- Optimized layout, higher torque output via face flange contrate gear connecting transmission.
- 法士特8檔變速箱，配置同步器；
- 優化的傳動軸布置，傳動軸傳動平穩、可靠。采用平面法蘭傳動軸，傳遞扭矩更大。

#### Brake 製動系統

- Service brake: air servo, dual circuit.
- Parking brake: Spring-loaded air chamber.
- Assisting brake: engine exhaust brake.
- 行車製動：雙回路氣壓製動；
- 駐車製動：彈簧蓄能製動；
- 輔助製動：發動機排氣製動。

#### Suspension system 懸掛系統

- Leaf spring suspension.
- 全部車軸懸掛裝置為鋼板彈簧的懸掛系統。

#### Transmission shaft 傳動軸

- Axles 2 is steered.
- 2軸為驅動軸。

#### Outrigger 支腿

- H-type layout, four point support, easy to operate, outrigger beam hydraulically telescoping.
- H型支腿4點支撐，易操作、穩定性強；活動支腿全液壓橫向伸縮。

#### Tires 輪胎

- 6 × 315/80R22.5 steel-belted vacuum tires, high load capacity and durability.
- 6 × 315/80R22.5，鋼絲真空輪胎，承載能力大，耐用。

# MACHINE INTRODUCTION

## 整機介紹

### ■ Superstructure 上車

#### Slewing platform 轉臺結構

- Turntable: SANY's self-manufactured structural component, made from high-strength steel, offers high torsional stiffness and long fatigue life.
- 三一自製結構件，高強度鋼材製造，扭轉剛度大、疲勞壽命長。

#### Operator's cab 操縱室

- Operator's cab: Features safety glass and corrosion-resistant steel plates, equipped with a load moment indicator display screen, electric windshield wipers, expansive interior space, panoramic sunroof, and adjustable seats.
- 採用安全玻璃，耐腐蝕鋼板；配置力矩限制器顯示屏，配有電動雨刮器，超大內部空間、全景式天窗、可調式座椅。

#### Hydraulic system 液壓系統

- 110ml/r large displacement 9 piston oil pump + load sensitive system, real-time adjustment of displacement, precise control of combined action.
- Hydraulic pilot handle, easy to operate.
- Quantitative piston motor + three-stage slewing reducer, more stable slewing start and control, excellent inching performance.
- 110ml/r大排量9柱塞油泵+負載敏感系統，排量實時調節、組合動作精準控制；
- 採用液壓先導手柄，操作更簡單、輕鬆；
- 定量柱塞馬達+三級回轉減速機，回轉啟動和控製更平穩，微動性卓越。

#### Control system 控製系統

- Bus instrument: integrated electrical bus instrument can control the driving parameters at any time. Engine fault prompting enables convenient and quick maintenance.
- Load Moment Indicator: The highly intelligent load moment indicator system fully protects the load operation, ensuring accurate, smooth and comfortable operation.
- 總線儀表：採用集成一體智能控製電氣系統的總線儀表，可隨時掌控行駕參數；擁有發動機故障提示功能，維修排故方便、快捷；
- 力矩限制器：採用高度智能力矩限制器系統，全方位保護吊載作業，確保操作精準、平穩、舒適。

#### Hoist 起升機構

- The winch adopts a high-quality fixed-displacement piston motor, making lifting and lowering of heavy loads faster and more stable.
- 卷揚採用高品質定量柱塞馬達，重物起落更快更穩。

#### Boom & telescoping system 伸縮系統

- 5-section U shape boom telescoping via single cylinder with rope arranger.
- 5節單缸繩排主臂，U型截面。

#### Luffing system 變幅系統

- Active luffing down, the luffing speed is uniform and controllable, improving the smoothness of luffing operation and reducing the energy consumption.
- 採用動力落幅系統，落幅速度均勻可控；降低能耗，提高落幅操作的平穩性。

#### Slewing 回轉系統

- 360° slewing, max. speed 2.5r/min. Stable operation, reliable system, smooth braking.
- 360°回轉，最大回轉速度2.5r/min，動作穩定，系統可靠，製動平穩。

#### Counterweight 配重

- Fixed counterweight 2t, no movable counterweight.
- 固定配重2t，無活動配重。

#### Safety equipment 安全裝置

- Hydraulic relief valve, balance valve, bidirectional hydraulic lock, load moment indicator, 3rd wrap protector, A2B (anti two-block).
- 液壓溢流閥、平衡閥、雙向液壓鎖、力矩限制器、三圈保護器、高度限位器。

# OPERATING RANGE - TELESCOPIC BOOM (T)

## 起升高度曲線 - 主臂

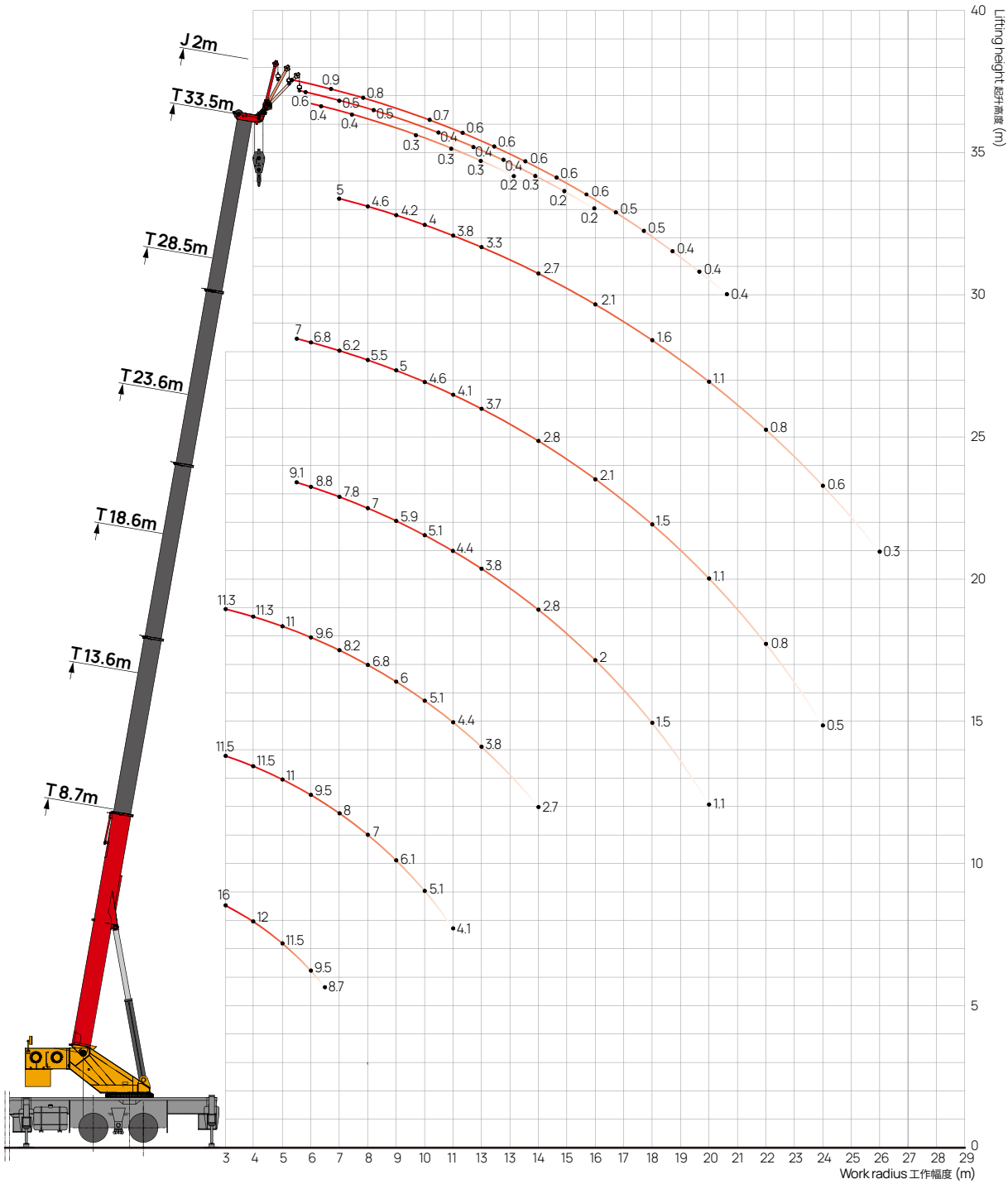







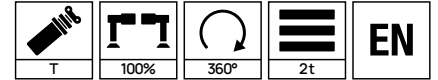





# LOAD CHART - TELESCOPIC BOOM (T)

## 性能表 - 主臂

Unit: t











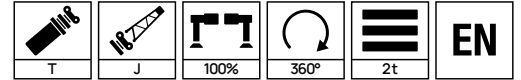

 m	8.7	13.6	18.6	23.6	28.5	33.5	 m
3	16.0	11.5	11.3				3
3.5	12.0	11.5	11.3				3.5
4	12.0	11.5	11.3				4
4.5	12.0	11.5	11.3				4.5
5	11.5	11.0	11.0				5
5.5	10.4	10.5	10.1	9.1	7.0		5.5
6	9.5	9.5	9.6	8.8	6.8		6
6.5	8.7	8.6	9.2	8.3	6.5		6.5
7		8.0	8.2	7.8	6.2	5.0	7
8		7.0	6.8	7.0	5.5	4.6	8
9		6.1	6.0	5.9	5.0	4.2	9
10		5.1	5.1	5.1	4.6	4.0	10
11		4.1	4.4	4.4	4.1	3.8	11
12			3.8	3.8	3.7	3.3	12
14			2.7	2.8	2.8	2.7	14
16				2.0	2.1	2.1	16
18				1.5	1.5	1.6	18
20				1.1	1.1	1.1	20
22					0.8	0.8	22
24					0.5	0.6	24
26						0.3	26
 C <sub>n</sub>	8	6	6	5	4	3	 C <sub>n</sub>
 2#	0	20	40	60	80	100	 2#
 3#	0	20	40	60	80	100	 3#
 4#	0	20	40	60	80	100	 4#
 5#	0	20	40	60	80	100	 5#

# LOAD CHART - TELESCOPIC BOOM + FIXED JIB (TJ)

## 性能表 - 主臂 + 副臂

Unit: t



	33.5+2						
	0°		15°		30°		
	 m	 t	 m	 t	 m	 t	
78	6.7	1.0	7.2	0.6	7.6	0.4	78
76	7.9	0.9	8.4	0.5	8.8	0.4	76
74	9.1	0.8	9.6	0.5	9.9	0.3	74
70	11.5	0.7	11.9	0.4	12.3	0.3	70
68	12.6	0.6	13.1	0.4	13.4	0.3	68
66	13.8	0.6	14.2	0.4	14.5	0.2	66
64	14.9	0.6	15.3	0.3			64
62	16.0	0.6	16.4	0.2			62
60	17.1	0.6	17.5	0.2			60
58	18.2	0.5					58
56	19.2	0.5					56
54	20.2	0.4					54
52	21.2	0.4					52
50	22.1	0.4					50
 C <sub>n</sub>	1		1		1		 C <sub>n</sub>
2#	100		100		100		2#
3#	100		100		100		3#
4#	100		100		100		4#
5#	100		100		100		5#









































































**Remark 備註:**

- The values given in the table represent the rated lifting capacities of the crane when it is properly leveled and operating on firm, level ground.
- The working radius in the table refers to the actual radius under load.
- Rated loads determined by stability are in accordance with ISO4305.
- The rated lifting capacities listed include the weight of the hook and lifting tackle (main hook: 110 kg, auxiliary hook: 52 kg).
- The values in the table apply to 360° all-round operations.
- When using the boom tip sheave, the rated lifting capacity must not exceed 2100 kg. If the jib is deployed, the rated lifting capacity of the boom must be reduced by 200 kg.
- If the actual boom length and working radius fall between two specified values, the rated lifting capacity corresponding to the longer boom and larger radius shall be used.

- 表中給定數值是在平整堅固的地面上，整機調平狀態下起重機的額定起重量。
- 表中工作幅度是指吊載後的實際幅度。
- 穩定性決定的額定載荷數值的確定遵循ISO 4305。
- 表中額定起重量包括起重鉤和吊具的重量(主鉤110kg, 副鉤52kg)。
- 表中數值適用於全方位(360°)作業。
- 使用臂尖滑輪時額定起重量不超過2100kg。若副起重臂處於展開狀態，主臂起吊的額定起重量應減少200kg。
- 如果實際臂長和幅度介於兩個數值之間時，取較長臂長及較大幅度所決定的額定起重量進行起吊作業。

# ICON DESCRIPTION

## 圖標說明

 Max. lifting capacity 最大起重重量	 Max. boom length 最大主臂長	 Max. lifting radius 最大吊載幅度	 Max. lifting height 最大吊載高度	 Driver's cab 駕駛室
 Carrier frame 車架	 Engine 發動機	 Transmission 變速箱	 Transfer case 分動箱	 Axle 車橋
 Outrigger 支腿	 Slewing platform 轉臺	 Suspension system 懸掛	 Steering 轉向	 Tires/Tire size 輪胎/輪胎尺寸
 Wheel formula 輪胎模式	 Transmission shaft 傳動軸	 Brake system 製動系統	 Electrical system 電氣系統	 Hydraulic system 液壓系統
 Operator's cab 操縱室	 Control system 控制系統	 Hoist 起升機構	 Slewing 回轉機構	 Safety equipment 安全裝置
 Load moment indicator 力矩限制器	 Counterweight 配重	 CW rearward positioned 配重後移	 Boom & telescoping system 主臂	 Luffing system 變幅系統
 Jib 副臂	 Superlift device 超起	 Wind power jib 風電副臂	 Luffing jib 塔臂	 Auxiliary jib 鵝頭臂
 Boom extension 主臂延伸臂	 Auxiliary boom nose 臂尖滑輪	 Rear storage box 尾部儲物箱	 Optional equipment at extra fees 選配	 Motor 電機
 Power battery 動力電池				
 Axle load 軸荷	 Weight 重量	 Number of sheaves 滑輪數量	 Min. travel speed 最小行駛速度	 Max. travel speed 最大行駛速度
 Max. gradeability 最大爬坡坡度	 Gear 檔位	 Onroad gear 高速檔	 Crawl speed 龜速檔	 Hook 吊鉤
 Main hook 主鉤	 Auxiliary hook 副鉤	 Rope rate 倍率	 Max. supporting forces 最大支撐力	 Outrigger pads 支腳盤
 Outrigger jack 垂直支腿	 Outrigger beam 水平支腿	 Front outrigger 前支腿	 Rear outrigger 後支腿	 Hook weight 吊鉤重量
 Operations 主要動作	 Max. single line lifting speed (empty load) 單繩速度(空載)	 Rope diameter 鋼絲繩直徑	 Rope length 鋼絲繩長度	 Max. single line pull 最大單繩拉力
 Main winch 主卷揚	 Auxiliary winch 副卷揚	 Full luffing up/down time of boom 主臂起落幅時間	 Full extension/retraction time of boom 主臂伸縮時間	 Anemometer 風速儀
 Spare tire 備胎				

# SANY OVERSEAS SERVICE

三一海外服務

# GLOBAL SUPPORT ANYTIME ANYWHERE NO MORE WAITING

900+



Overseas service centers  
海外服務中心

3500+



Professional technical  
service engineers  
專業技術服務

365×24



Support  
全時服務

### Service Center

Tel: +86 4006098318

Mail: CRD@sany.com.cn

WhatsApp: +86 19908478631 (Only WhatsApp)

## My SANY

On-demand professional equipment repair services available anytime, anywhere, ensuring rapid response and efficient solutions.

隨時一鍵呼叫專業設備維修服務，快速響應，高效解決。



Download MySANY for a comprehensive, all-in-one experience!

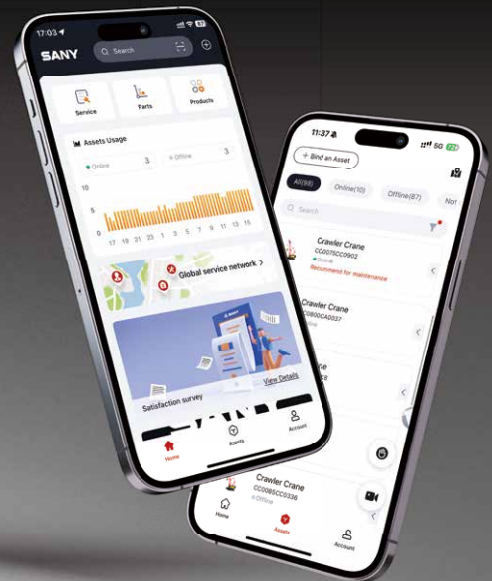

# SANY®

## SANY Mobile Crane and Tower Crane Industrial Park

No.168 Jinzhou Avenue, Jinzhou Development Zone, Changsha City, Hunan Province, P.R. China Zip 410600

## SANY Crawler Crane Industrial Park

No. 2188 Daishan Road, Wuxing District, Huzhou City, Zhejiang Province, P. R. China Zip 313028

Consulting [sanycrane@sanygroup.com](mailto:sanycrane@sanygroup.com) (Crane BU) / [crd@sany.com.cn](mailto:crd@sany.com.cn) (IHQ)

After-sales Service 0086-400 609 8318 (Overseas)

### Reminder:

Any change in the technical parameters and configuration due to product modification or upgrade may occur without prior notice. The machine in the picture may include additional equipment. This brochure is for reference only, and goods in kind shall prevail.

Copyright at SANY. No part of this brochure may be copied or used for any purpose without written approval from SANY.

© Version 2025-11-17

三一輪式、塔式起重機產業園：中國湖南長沙金洲開發區金洲大道168號 郵編：410600

三一履帶起重機產業園：中國浙江湖州市吳興區黛山路2188號 郵編：313028

諮詢：[sanycrane@sanygroup.com](mailto:sanycrane@sanygroup.com)(起重事業部) / [crd@sany.com.cn](mailto:crd@sany.com.cn)(國際總部)

售後服務：0086-400 609 8318(海外)

### 溫馨提示：

由於技術不斷更新，技術參數及配置如有更改，恕不另行通知。圖中機器可能包括附加設備，本畫冊僅供參考，以實物為準。

版權為三一所有，未經三一書面許可，本畫冊任何內容不得被複製用於任何目的。

© 2025年11月17日版



Contact SANY Group



Follow SANY Group

SANY CRANE | [f](#) [in](#) [v](#) | [globe](#) [www.sanyglobal.com](http://www.sanyglobal.com)