



snapmaker

Artisan 3D Printer (Premium 3-in-1 Addons)

ASSEMBLY GUIDE

 Laser Engraving and Cutting

 CNC Carving and Cutting

 Enclosure

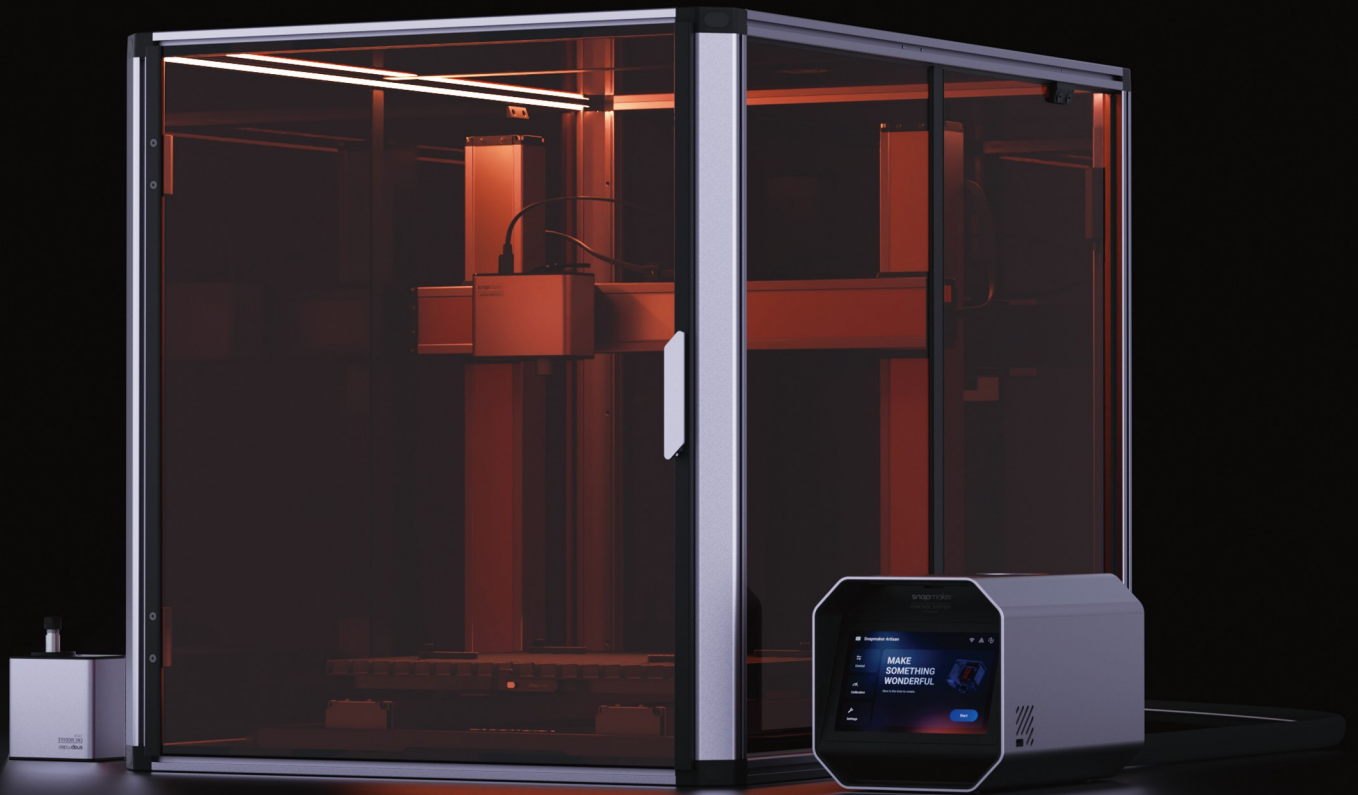

CONTENTS

- Before You Start01**
 - 1.1 Disclaimer..... 02
 - 1.2 Intended Use 02
 - 1.3 Safety Information..... 03
 - 1.4 Safety Labels on Your Snapmaker 06
 - 1.5 Specifications..... 07
 - 1.6 Parts List 08
 - 1.7 Assembly Instructions..... 10
 - 1.8 Used Symbols..... 12
 - 1.9 About This Guide..... 12

- Enclosure Assembly and Settings13**
 - 2.1 Enable/Disable Door Detection 58
 - 2.2 Turn On/Off LED Strips and the Exhaust Fan..... 60

- Laser Engraver and Cutter Assembly61**

- CNC Carver and Cutter Assembly77**

- Resources84**

Before You Start



1.1 Disclaimer

Make sure that anyone who uses this product knows and understands the contents of the Assembly Guide. Failure to observe this guide may lead to personal injury, inferior results, or damage to the Snapmaker products.

Snapmaker does not assume responsibility and expressly disclaims liability for any personal injury, inferior results, or damage to the product arising out of or in connection with your improper operations or failure to follow the instructions of the guide.

When using Snapmaker products, you should comply with the following requirements:

- Follow the instructions of this guide, the applicable laws and regulations, and the safety regulations in the assembly, handling, storage, use, maintenance, or disposal of this product.
- Ensure there is no infringement on any third-party intellectual property rights or violation of any applicable laws or regulations when making objects using this product.

The conditions or methods of using Snapmaker products are beyond the control of Snapmaker. For this reason, Snapmaker does not assume responsibility and expressly disclaims liability for any consequences resulting from:

- your improper methods, failure to follow the instructions of this guide or impacts of other uncertain factors when operating this product;
- your infringement on any third-party intellectual property rights or violation of any applicable laws or regulations when making objects using this product;
- personal injury, inferior results, or damage to the product arising out of or in connection with the assembly, handling, storage, use, maintenance, or disposal of this product.

All the Snapmaker filaments and materials are compatible with this product and have been tested for safety. If you use this product with third-party filaments or materials, Snapmaker does not assume responsibility and expressly disclaims liability for any adverse effects from the use or performance of these filaments and materials.

This guide is provided for reference purposes only. We do not warrant the absolute accuracy or completeness of the information provided by this guide. No part of this guide may be reproduced, edited, or revised by any means without the prior written permission of Snapmaker. We reserve the right to modify or revise this guide in our sole discretion at any time without notice.

1.2 Intended Use

Snapmaker modular 3D printers are intended for use under the guidelines provided in this guide. When making objects using Snapmaker modular 3D printers, users remain responsible for qualifying and validating the application of the created object for its intended use, especially for applications in strictly regulated areas like medical devices and aeronautics.

1.3 Safety Information

1.3.1 General Safety Information

- Follow the applicable local laws and regulations in the operation and application of this product.
- Follow the instructions of the guide to use and maintain this product for safety purposes.
- Do not expose this machine to rain or wet conditions.
- Always operate this machine indoors on a solid horizontal table or workbench.
- Minors are only allowed to use this product under adult supervision and assistance.
- Ensure that bystanders also read and understand all the safety notes of this product and keep bystanders away while operating this product for safety purposes.
- Stay alert, watch what you are doing, and pay attention to the surrounding environment when operating this product.
- Do not use this product while you are tired or under the influence of drugs, alcohol, or medication.
- Do not reach inside the product or touch the moving parts while the product is still in operation.
- Do not leave the product unattended while it is still powered on.
- Always unplug the power cable from the electrical outlet before performing maintenance or modifications.

Turn off the machine immediately and stop using this product if any of the following occurs:

- You smell burning in this product at any point.
- You see any damage to the interior components of this product.
- The machine stops working unexpectedly.
- Unusual lights, sparks, or sounds come out of this product which has never occurred previously.

1.3.2 Laser Safety Information

- The Laser Module is a Class 4 laser product. When you use the laser module correctly and in combination with the Enclosure as required, the overall laser classification of this product is Class 1.
- You should operate this product only if you have sufficient knowledge of (i) the physical properties of laser radiation, (ii) Laser Hazard Classes and associated health implications, and (iii) safety measures.
- The Laser Module must be used together with the Enclosure. Please follow this guide to assemble and use the Enclosure. During laser processes, the Enclosure helps to prevent the risk of laser leakage by effectively filtering laser radiation and pausing the ongoing job if the Enclosure door is opened.
- An air purifier should be used depending on the type and constituent of the materials you are going to use, as some materials may release hazardous and toxic fumes when laser engraved or cut. Ensure that the air purifier you choose is effective enough to protect human health and prevent environmental pollution.
- Do not directly look at or touch the laser aperture or expose yourself to the laser beam during operation.
- Ensure that there is no reflective material within the work area during operation, as it may cause scattered radiation and pose safety risks.
- Ensure that there is no flammable and explosive material within the work area or around the machine during operation, as it may cause a fire.
- The Laser Module mustn't be used with the 3D printing platform and the CNC carving and cutting platform (allowed only in the 4-axis machining scenario, for the Rotary Module can only be attached to the CNC platform). Otherwise, it might damage the mismatched work platform, cause a fire, or pose other risks.

1.3.3 CNC Safety Information

- Users of the CNC Module should be at least 18 years old and have relevant experience.
- Use the CNC Module together with the Enclosure.

- All the users and bystanders must wear the CNC safety goggles during operation.
- Before a CNC process, make sure to securely clamp the material.
- During a CNC process, never attempt to hold the workpiece with your hands.
- If the bit or workpiece becomes jammed or bogged down, turn off the machine immediately. Wait for all the moving parts to stop, unplug the cable, and then work to free the jammed material.
- Do not touch the bit or the collet right after use, as doing so could cause burn injuries.
- The toxic substances contained in some materials might be released in CNC carving and cutting processes. To reduce the harm, use the CNC Module with air purifying devices or in a well-ventilated environment and take safety precautions, such as wearing a mask.

1.3.4 Enclosure Safety Information

- To move the Enclosure or the machine, you must first separate the machine and the Enclosure.
- Do not scrape, bend or break the acrylic panels, profiles, or the door handle. Doing so can compromise protection, cause permanent damage to the Enclosure, or even cause personal injuries.
- Do not place the Integrated Controller inside the Enclosure when using this product.
- Do not place objects that weigh more than 7 kg on top of the Enclosure. Otherwise, the top panel will be damaged.
- Do not put any objects or body parts into the exhaust fan when the fan is operating.
- Keep the cables away from the exhaust fan blades to avoid damaging the exhaust fan or other parts of this product.

1.3.5 Precautions and Emergency Measures

Laser Engraving and Cutting

Eye Injury from Laser

If your eyes are exposed to direct or scattered laser beams, take the following measures immediately:

1. Grab a nearby thick and opaque object to block the laser beam, preventing further exposure to laser.
2. Shut down the laser engraver and cutter immediately.
3. If an eye injury is suspected, a medical examination by a qualified specialist needs to be carried out as soon as possible.
4. If an eye injury is apparent, call the local hospital for emergency help.

Skin Injury from Laser

Lasers can harm the skin via photochemical or thermal burns. When you suffer from skin burns caused by lasers, take the following steps as an emergency response:

1. If it is a major burn, call for emergency medical care before you take the subsequent steps.
2. Remove any clothing or jewellery near the burnt area of skin, but do not move anything that's stuck to the skin.
3. Hold the burn under cool or lukewarm running water until the pain subsides. Use cool, wet compresses if running water isn't available.
4. After the burnt area has been cooled, use painkillers such as paracetamol or ibuprofen to treat any pain.
5. Use a sterile, non-adhesive bandage or clean cloth to loosely bandage the burn.

Exposure to Gases or Fumes

The heating which occurs during laser cutting or engraving can cause charring, pyrolysis, or even combustion of the material being worked on and generate gases or fumes.

- Airway Irritation

Gases and fumes may irritate the airways and potentially be extremely dangerous. If airway irritation occurs,

take the following steps as an emergency response:

1. Expose the casualty to fresh air.
2. Call for medical help.
3. If the person is unresponsive, not breathing, or not breathing normally, perform CPR until the person begins breathing or emergency help arrives.

- Eye Irritation

Being exposed to gases or fumes may cause the eyes to become red and watery, and induce a grainy feeling. Should eye irritation occur, take the following steps as an emergency response:

1. Rinse the affected eyes with room temperature water for 10 to 20 minutes to relieve symptoms. Sterile water or sterile normal saline solution (0.9%) from sealed disposable containers can be used. Press the eyelids wide open and keep them apart while rinsing.
2. Transfer the casualty to the hospital as soon as possible for an eye examination and further treatment.

Fire

Laser engraving and cutting can present a significant fire hazard due to the extremely high temperature caused by the laser beam. If a fire occurs, take the following steps as an emergency response:

1. If the fire is small in size (no larger than a small trash can), you can use an extinguisher to put it out. Before dousing the flame, remember to cut electrical power.
2. If the fire is large, call for help immediately by pulling the nearest alarm and do not attempt to fight it yourself.
3. Move quickly to the nearest accessible exit. Notify and assist others in evacuating along the way. Do not use the elevators.
4. Contain the fire and the smoke by closing all doors leading into and surrounding the fire area. Do not lock them.
5. After a total and immediate evacuation, call medical attention for the casualty.

CNC Carving and Cutting

Injury from Sharp Objects

If you get injured from sharp objects, take the following steps as an emergency response:

1. Apply pressure to the wound with a clean cloth for a few minutes until the bleeding stops. If the bleeding won't stop or other tissues are severely injured, seek medical help immediately.
2. Use sterilized tweezers to remove dirt and debris around the wound. If the debris penetrates deep into your skin, seek medical help immediately.
3. Gently rinse the wound, and wipe away the residual water with a clean cloth.
4. Apply antiseptic cream on the wound to prevent infection. If the wound is infected, seek medical help immediately.
5. Use a bandage to protect the wound from further exposure to dirt and bacteria.

Any injuries to vulnerable parts, like faces, eyes, and arteries, require immediate medical treatment.





Inhalation of Dirt and Sawdust

CNC carving and cutting produce dust and sawdust, which might irritate your respiratory system. Generally, we recommend you use air-purifying devices and wear protective masks when carving and cutting. If respiratory irritation occurs, immediately expose the casualty to fresh air and seek medical help.

Inhalation of Scorched Smell

Sometimes, CNC carving and cutting can emit a scorched smell, which might irritate your respiratory system. Generally, we recommend you carve and cut with air-purifying devices or in a well-ventilated environment. If respiratory irritation occurs, immediately expose the casualty to fresh air and seek medical help.

1.4 Safety Labels on Your Snapmaker

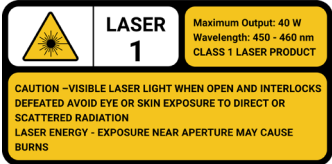
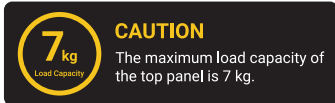
Label	Warning	Location
	<p>Take care to avoid injury from sharp objects (e.g., CNC bits).</p>	<p>On the 200W CNC Module</p>
	<p>Laser radiation is emitted from this aperture. Do not touch the aperture, and avoid eye and skin exposure to direct or scattered radiation.</p>	<p>On the Laser Module</p>
	<p>Class 4 laser product. Avoid eye and skin exposure to direct or scattered radiation.</p>	<p>On the Laser Module</p>
		
	<p>Class 1 laser product. Avoid eye and skin exposure to direct or scattered radiation when the interlocks are defeated.</p>	<p>On the Enclosure Door</p>
	<p>Do not place objects that weigh more than 7 kg on this surface.</p>	<p>On the top panel of the Enclosure</p>

* The photographs in this guide take the safety label required in the EU region as an example.

* The same label on different locations may vary in color or texture.

1.5 Specifications

Enclosure			
Minimum Footprint (W × D × H)	1035 mm × 1690 mm × 705 mm		
Material	Profile: Aluminum alloy	Panel: Acrylic sheet	
Laser Engraving & Cutting			
Work Area (X × Y)	400 mm × 400 mm	Power	40 W
Laser Type	450 nm–460 nm Semiconductor	Laser Classification (within Enclosure)	Class 1
Max. Work Speed	200 mm/s	Max. Cutting Speed	20 mm/s
Operating Temp.	0°C–35°C	Laser Spot Dimensions	0.1 mm × 0.15 mm
Supported Materials for Engraving	Basswood, Paulownia, Pinewood, Plywood, Beech, Walnut, Bamboo, MDF, Painted Metal, Tinplate, Stainless Steel, Anodized Aluminum, Dark Glass, Slate, Ceramics, Jade, Marble, Shale, Leather, Fabric, Canvas, Corrugated Paper, Cardboard, Plastic, Dark Acrylic (Blue excluded)		
Supported Materials for Cutting	Basswood, Paulownia, Pinewood, Plywood, Beech, Walnut, Bamboo, MDF, Leather, Fabric, Canvas, Corrugated Paper, Cardboard, Plastic, Dark Acrylic (Blue excluded)		

CNC Carving & Cutting		Snapmaker Luban	
Work Area (X × Y)	400 mm × 400 mm	Supported OS	Windows, macOS, Linux
Power	200 W	Supported File Formats	3D Printing: .stl, .obj Laser Engraving and Cutting: .stl, .svg, .png, .jpg, .jpeg, .bmp, .dxf CNC Carving and Cutting: .stl, .svg, .png, .jpg, .jpeg, .bmp, .dxf
Max. Spindle Speed	18,000 RPM	Generated File Formats	3D Printing: .gcode Laser Engraving and Cutting: .nc CNC Carving and Cutting: .cnc
Max. Work Speed ¹	Beech: 50 mm/s Acrylic: 33 mm/s		
Max. Stepdown	Beech: 2 mm Acrylic: 1 mm		
Shank Diameter	0.5 mm–6.35 mm		
Supported Materials	Hardwood (Beech, Walnut), Softwood, HDF, MDF, Plywood, Jade, Carbon Fiber, Acrylic, Epoxy Tooling Board, PCB		

[1] The data is obtained by cutting Beech with the 3.175 mm flat end mill (double-flute) and Acrylic with the 3.175 mm flat end mill (single-flute). The cutting speed might vary depending on the CNC bits and materials used.

* The specifications above are subject to change as we improve the product.

1.6 Parts List



Assembly Guide
x 1



Profile Connector
x 6



Short Beam
x 1



Short Beam (with profile connectors)
x 1



Short Beam (with screw holes)
x 2



Long Beam
x 2



Long Beam (with tube holder)
x 2



Middle Column
x 2



Middle Beam
x 1



Side Panel
x 2



Side Panel (with tube holder cutout)
x 2



Top Panel
x 2

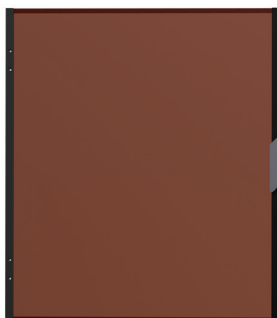

Door Panel
x 1



Back Panel
x 1

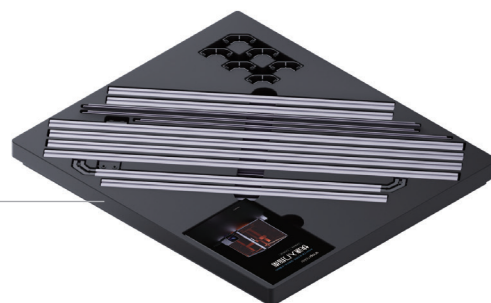

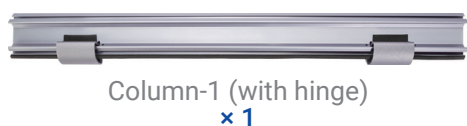

Column-1 (with hinge)
x 1

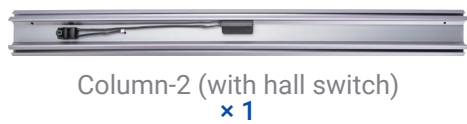

Column-2 (with hall switch)
x 1

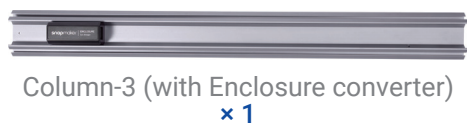

Column-3 (with Enclosure converter)
x 1

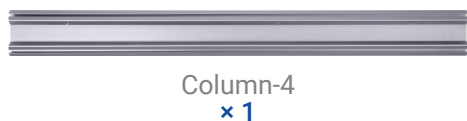

Column-4
x 1

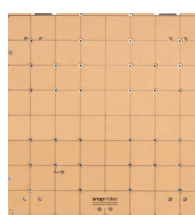

CNC Carving and Cutting Platform
x 1



Laser Engraving and Cutting Platform
x 1

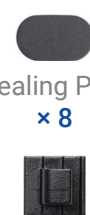

Sealing Plug
x 8



Filament Tube Clip
x 2



40W Laser Module
x 1



200W CNC Module
x 1



ER11 Collet & ER11 Nut
x 1



Basswood Sheet
x 1



HDF Sheet
x 1



Exhaust Fan Guard
x 1



Cord Collecting Strip
x 1



Filament Tube
x 2



Hose Connector
x 1



Boosted Exhaust Fan
x 1



Hose
x 1



CNC Safety Goggles
x 1



Cable Pass-through Fixture
x 1



Base Fixture (upper) x 2
Base Fixture (lower) x 2



Star Knob
x 4



Arched Fixture
x 4



Fixture Accessory
x 4



Hose Clamp
x 1



Straight Groove V-bit (double-flute)
x 1



Flat End Mill (single-flute)
x 1

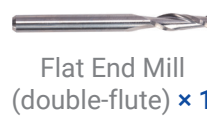

Flat End Mill (double-flute)
x 1



14mm Open-end Wrench
x 1



17mm Open-end Wrench
x 1



M4 x 12 Flat Head Screw
x 5



M5 x 12 Screw
x 20



M4 x 20 Screw
x 7



M5 x 16 Low Head Cap Screw
x 12



M5 x 30 Screw
x 20



M4 Wing Nut
x 5



Laser Material Fixture
x 4
M6 x 16 Screw x 8



L Bracket x 1
M4 x 12 Low Head Cap Screw x 2



M4 x 40 Screw
x 5



Laser Lens Protector
x 1



Enclosure Cable
x 1



Sealing Strip (wide)
x 1



Sealing Strip (narrow)
x 1



M4 x 60 Screw
x 4



Cotton Swab
x 5

* The appearance of certain parts may change with product iterations, while their functionalities in offering a reliable user experience will remain unaffected.

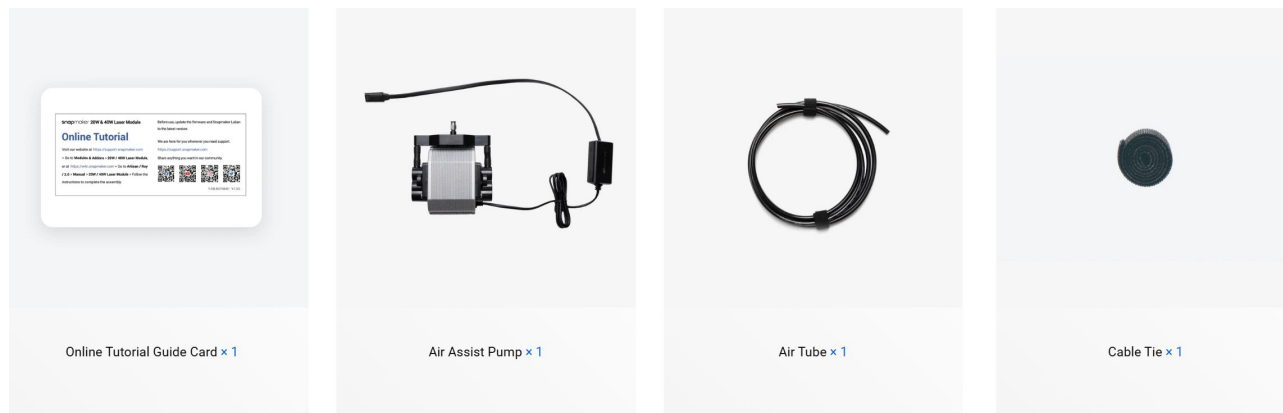

1.7 Assembly Instructions

1.7.1 Video Tutorial

To assemble the Enclosure and 200W CNC, you can read the following instructions or go to our YouTube channel @Snapmaker to watch the video tutorial and complete the assembly.



To avoid missing any important details, **please play the videos on a device with a large screen.**

To minimize the assembly time and effort, we recommend that you assemble in the following order:

Machine > Enclosure > 3D Printer/Laser Engraver and Cutter/CNC Carver and Cutter.

To start your first job, please visit our Wiki website (https://wiki.snapmaker.com/en/snapmaker_artisan/manual/): **Snapmaker Artisan > Manual > Getting Started > Start Your First Job.**

1.7.2 Tips & Notes

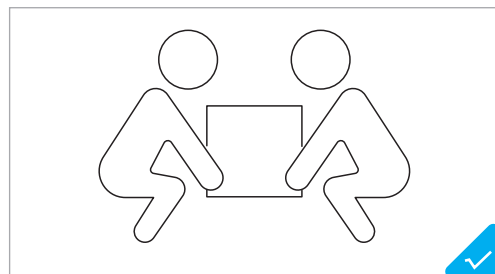

At least two people are required to assemble and lift the machine and the Enclosure.

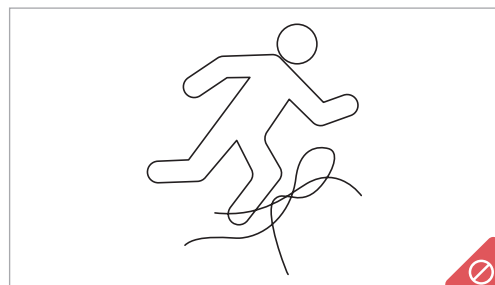

Collect and sort the cables in time lest anyone should trip over them.

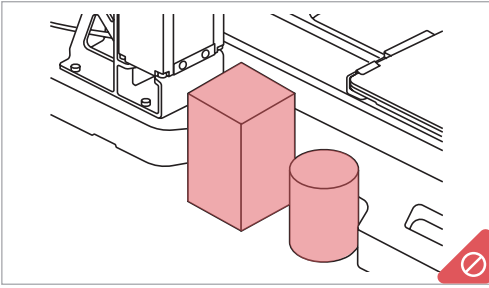

Do NOT place any object near the left or the right side of the base plate to avoid interfering with the movement of the Linear Modules and the work platforms.

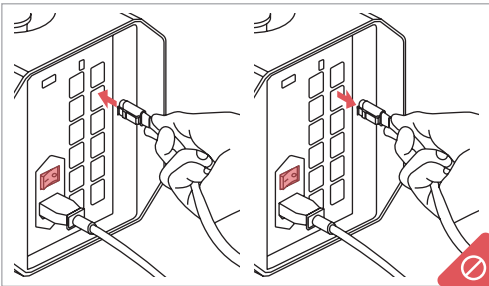

Do NOT plug or unplug any cables when the machine is powered on.

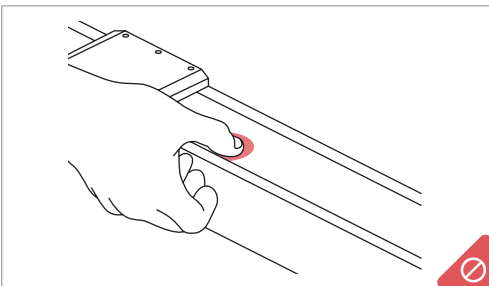

Do NOT press the steel strip. If the steel strip comes out, flatten it by hand from either end of the linear module to the other end.

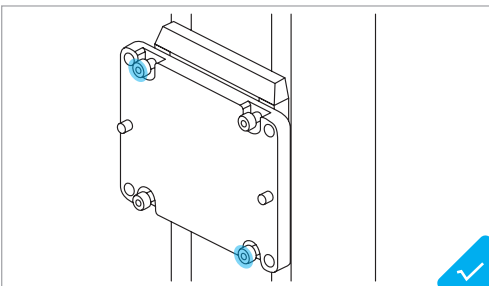

To install multiple screws in one step:

1. Pre-tighten the screws at the outermost corner;
2. Pre-tighten the remaining screws;
3. Tighten all the screws in the pre-tightening order.

* Pre-tighten: To screw the screw into the hole, yet not fully tighten it.

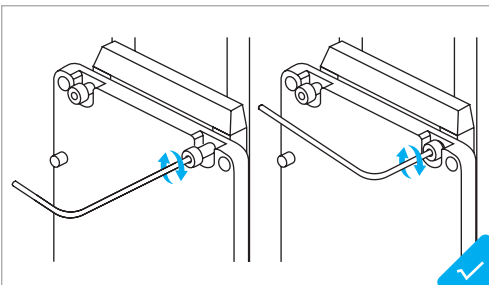

To install screws with the provided hex key:

1. Screw the screw into the hole with the long handle;
2. Tighten the screw with the short handle.

1.8 Used Symbols



WARNING

Failure to observe this instruction may lead to damage to the product or personal injury.



CAUTION

Details you should pay attention to when using the printer.



TIPS

Provides convenient operations or extra choices.

1.9 About This Guide

This Assembly Guide is intended to guide you through the assembly of Laser Engraver and Cutter, CNC Carver and Cutter, and familiarize you with the Enclosure settings with concise instructions and graphics. Our online User Manual is considered as a more comprehensive guide. To bring your first job into the world, go to Snapmaker Wiki (<https://wiki.snapmaker.com/>).

Enclosure Assembly and Settings

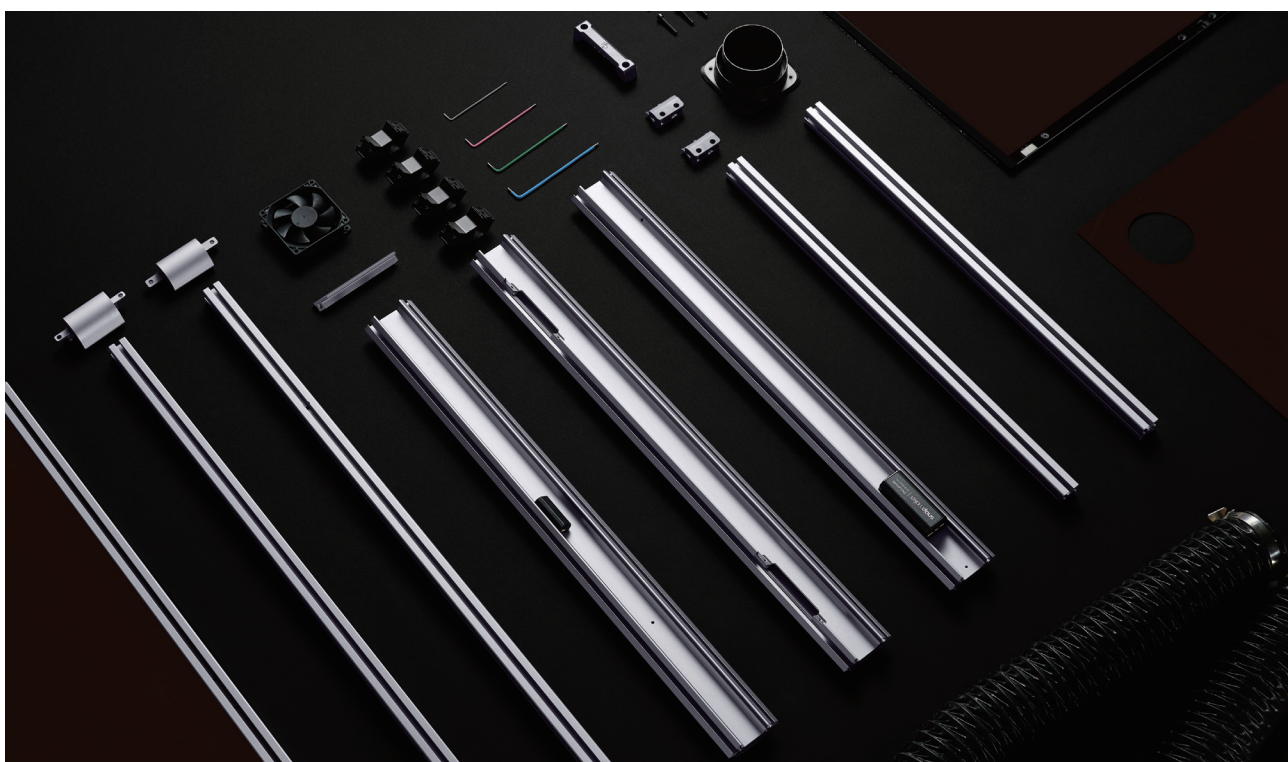



Well begun is half done.
Are you ready?

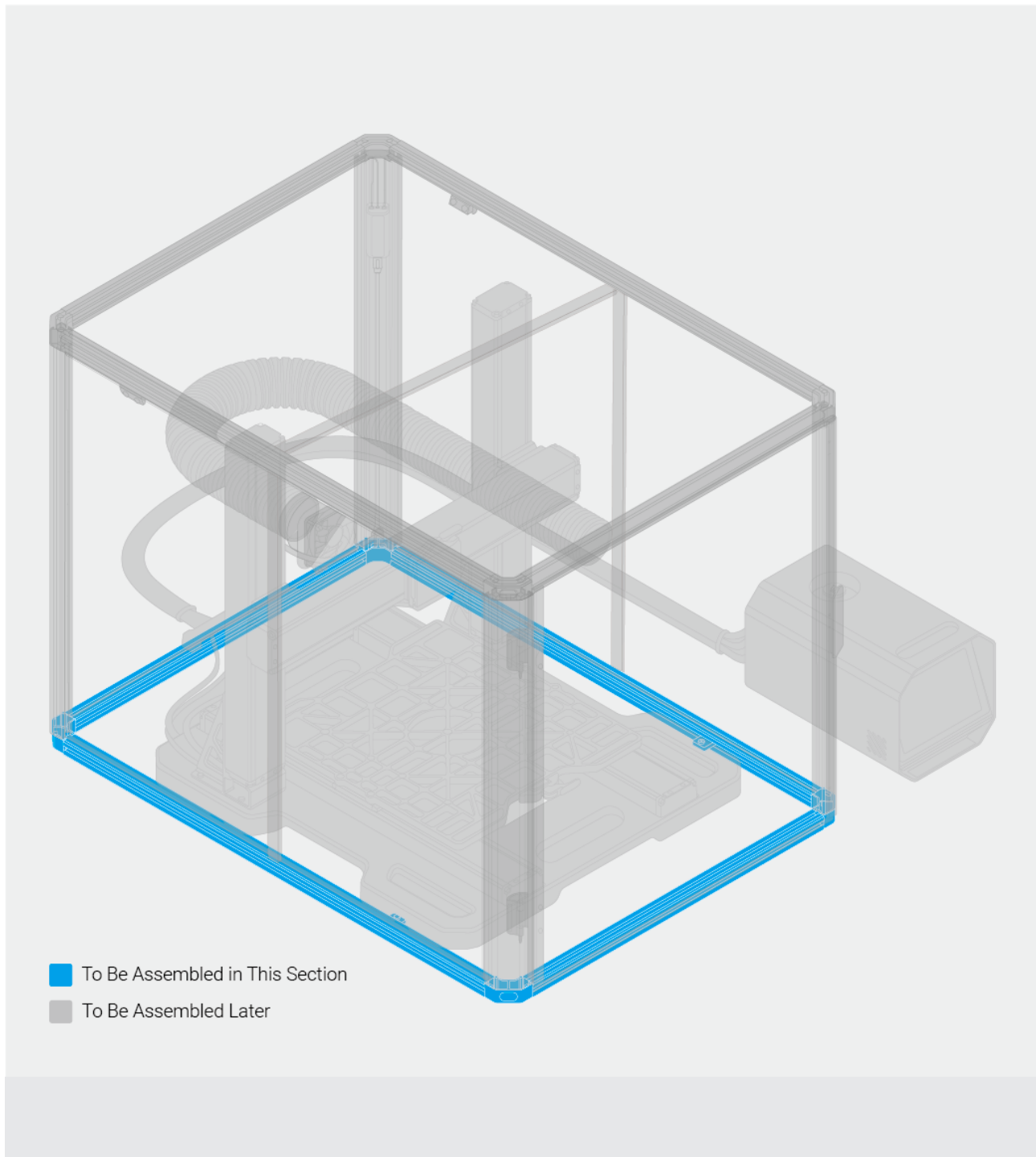

01 /36

Attach the two base fixtures (upper) to the two long beams.

M4 × 20 Screw × 2

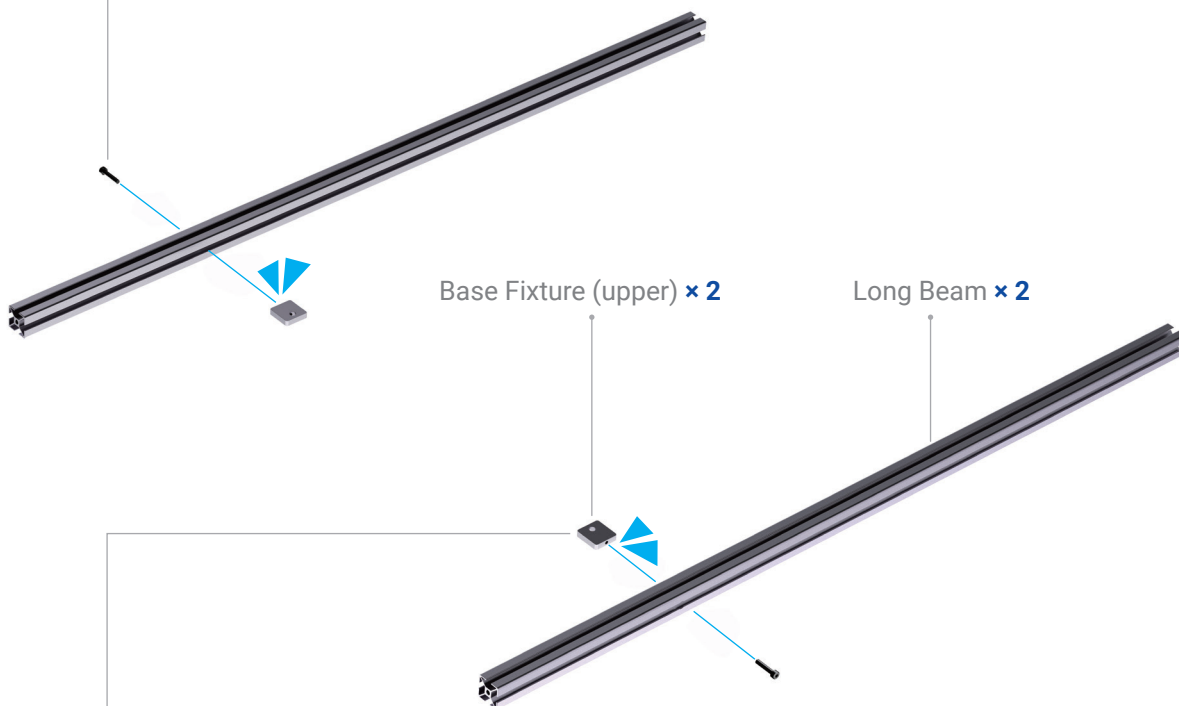

Ensure that the side of the beam with the screw cutout faces outwards.

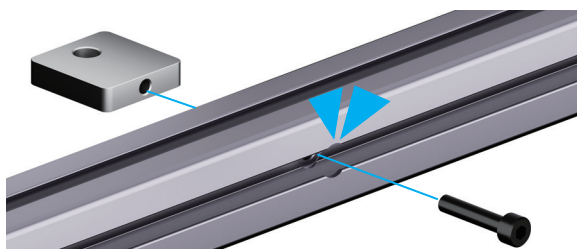

02 /36

Attach the profile connectors to both ends of the long beams.

M5 × 12 Screw × 4



Make sure all four profile connectors are inside up.

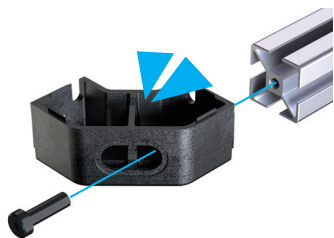

Make sure the alignment tabs of the profile connectors are inside the beam grooves.

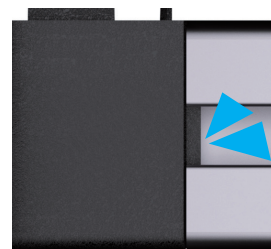

03 /36

Attach the short beam (with screw holes) to the profile connectors.

M5 × 12 Screw × 2

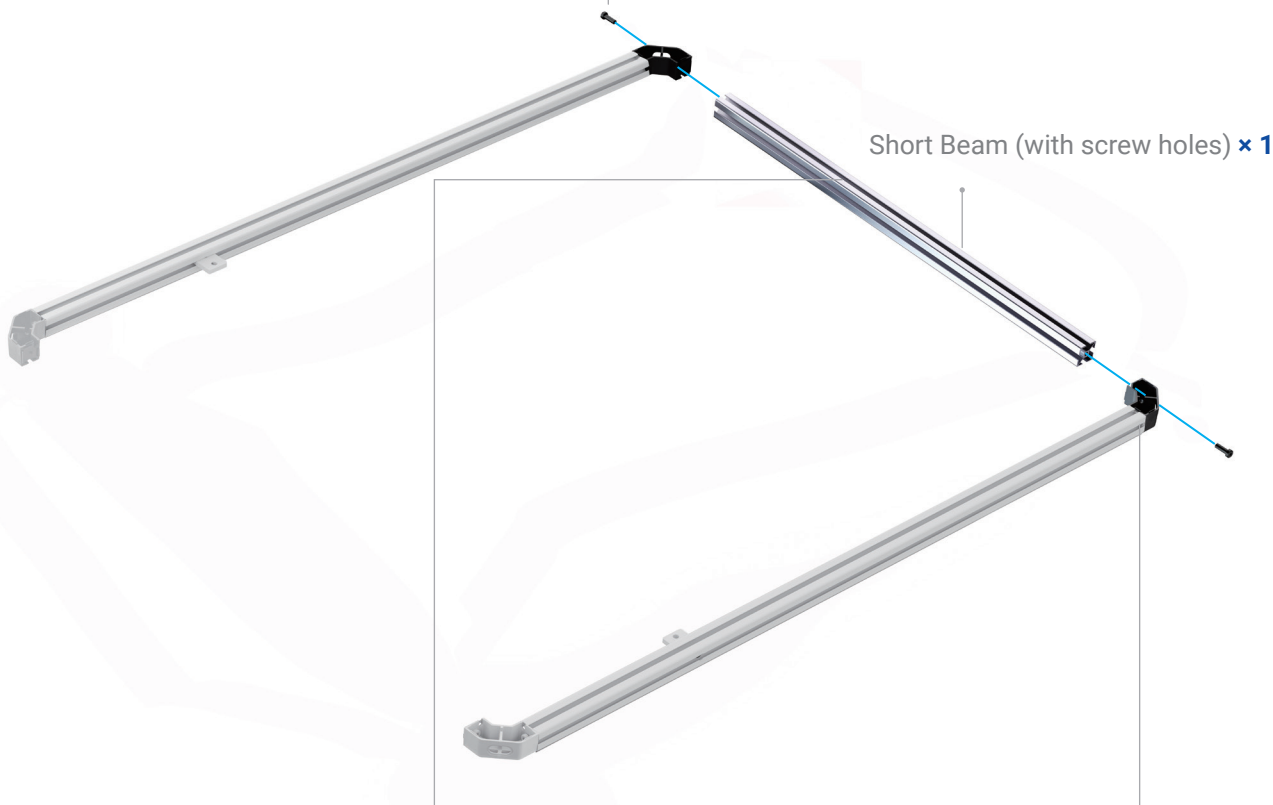

Make sure the two screw holes of the short beam (rear) are oriented vertically.

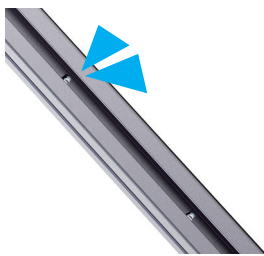

Make sure the alignment tabs of the profile connectors are inside the beam grooves.

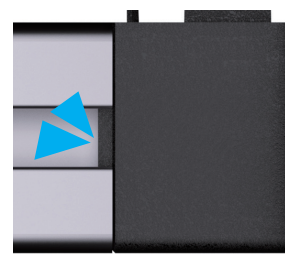

04_{/36}

Attach the short beam to the profile connectors.

M5 × 12 Screw × 2

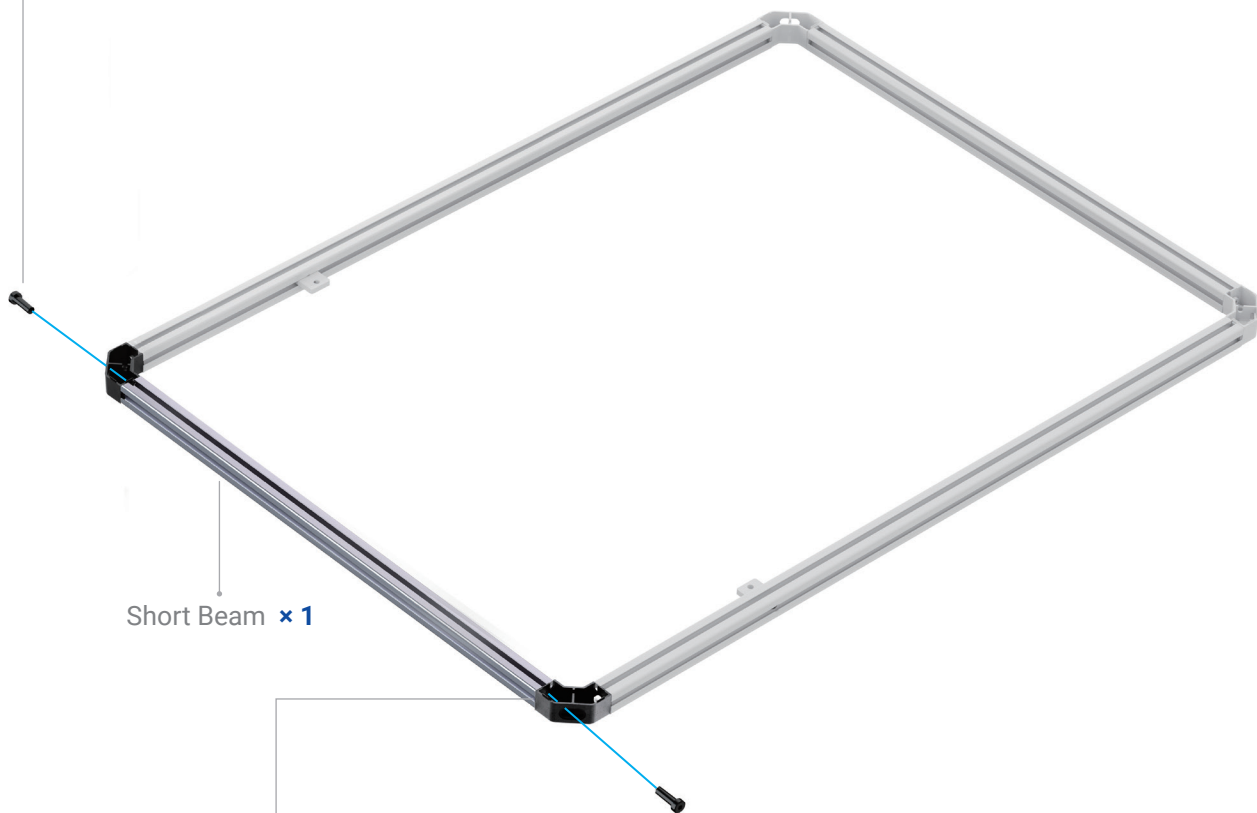

Short Beam × 1



Make sure the alignment tabs of the profile connectors are inside the beam grooves.

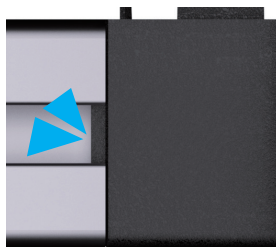



Let's install the columns and
Complete 25% of the race!

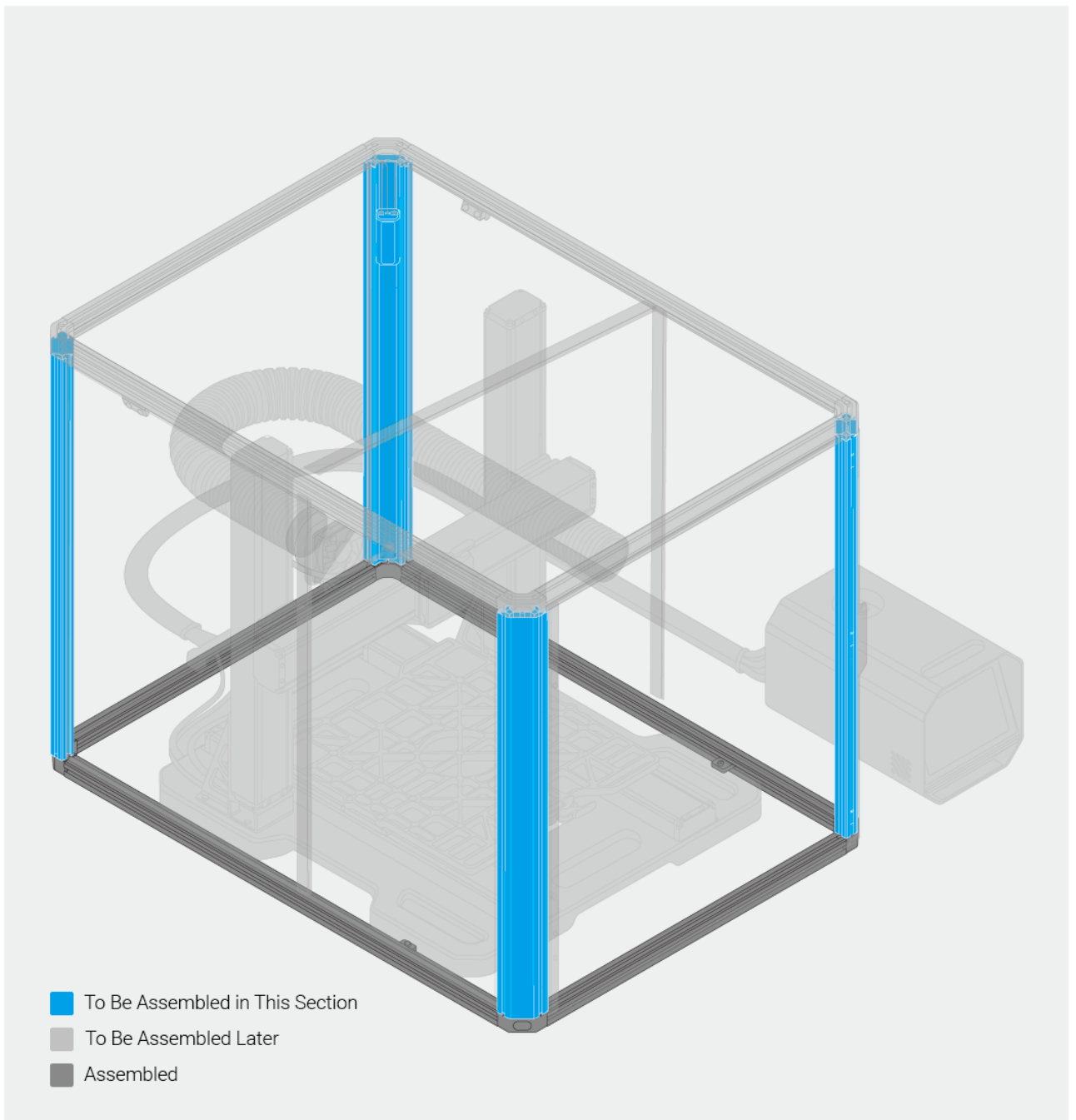

05_{/36}

Attach the column-1 (with hinge) to the bottom frame.

M5 × 30 Screw × 2



1:1



You can also erect the bottom frame and install the columns as illustrated.



Column-1 (with hinge) × 1

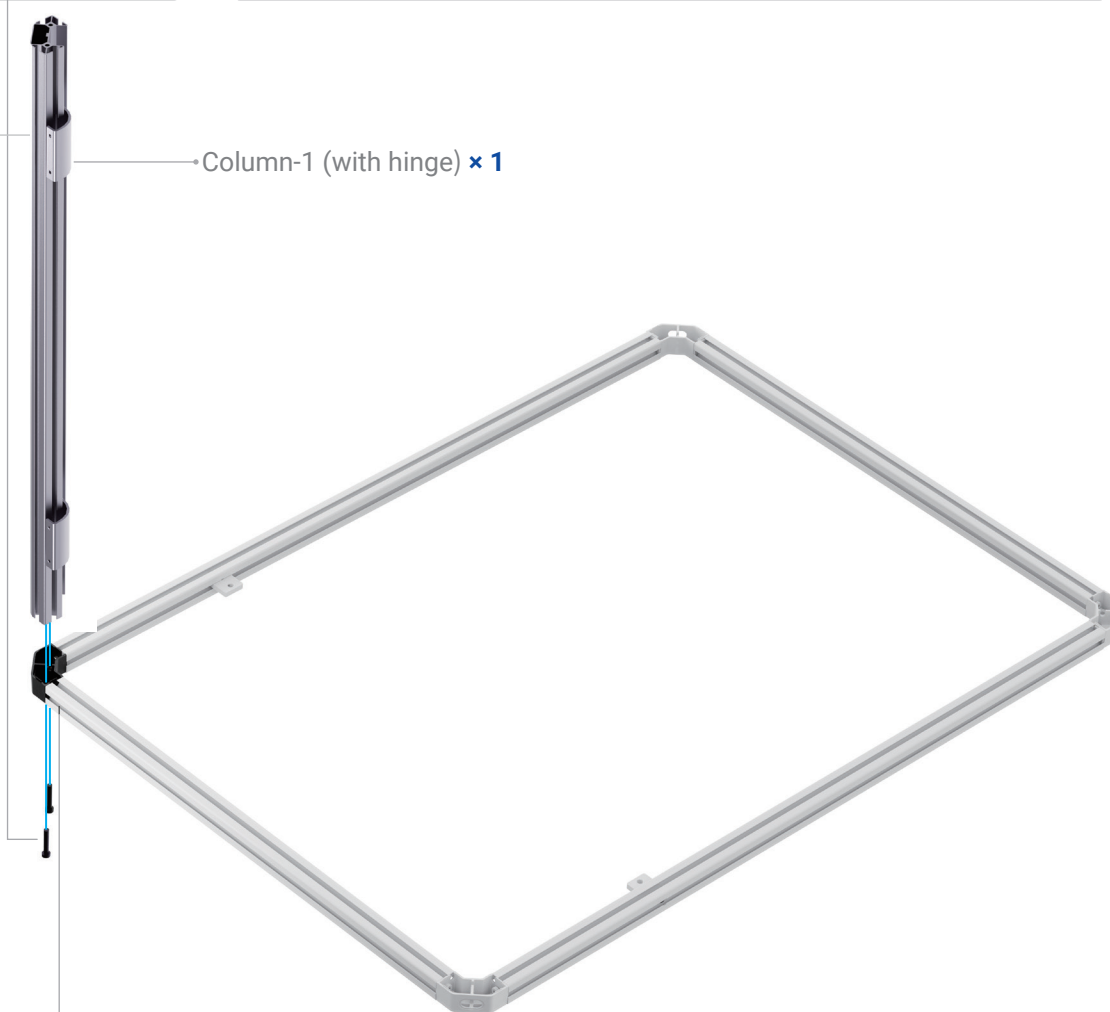

Make sure the alignment tabs of the profile connectors are inside the column grooves.

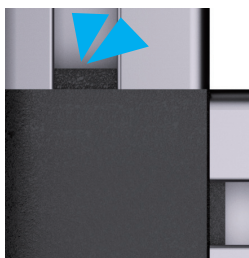

06 /36

Attach the column-2 (with hall switch) to the bottom frame.

M5 × 30 Screw × 2



1:1

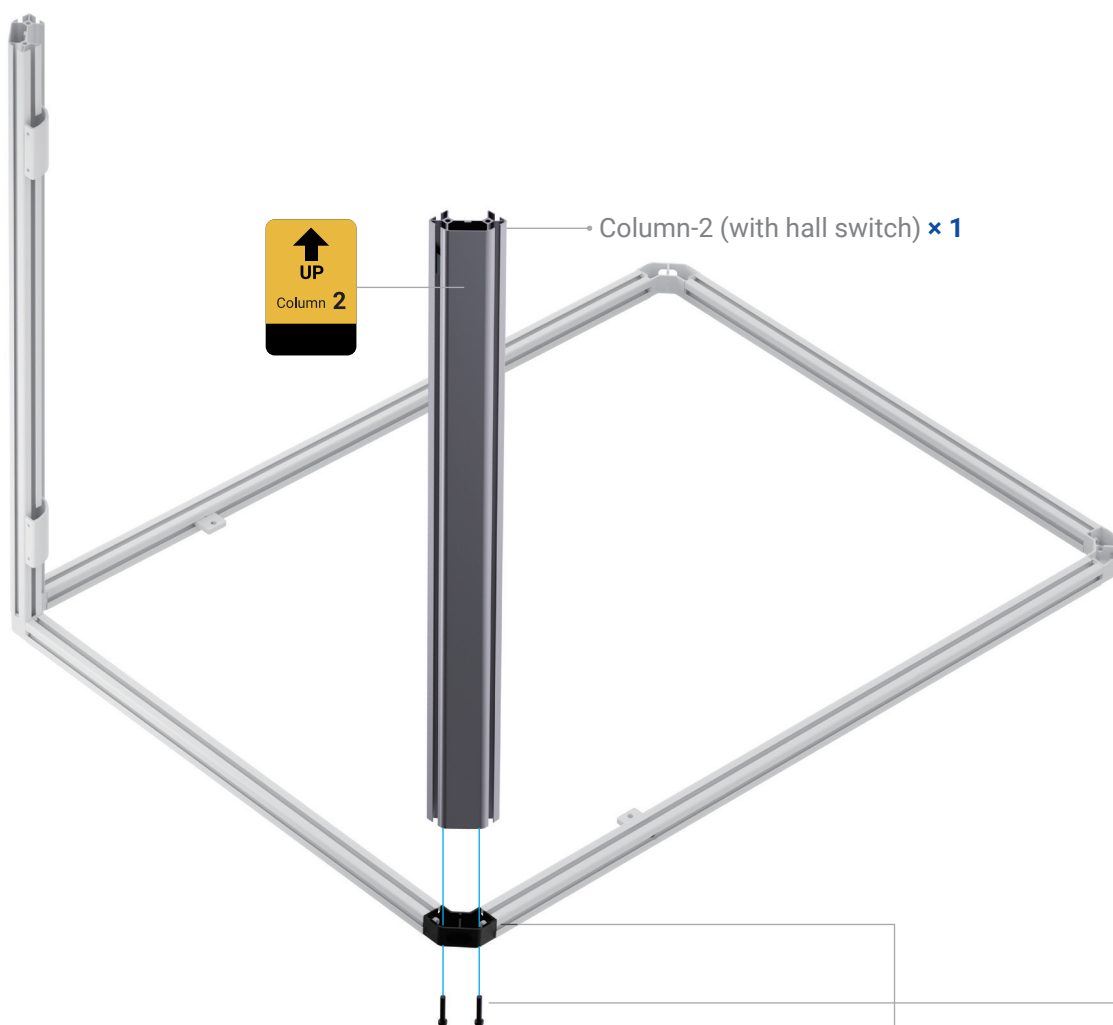

Make sure the alignment tabs of the profile connectors are inside the column grooves.



07 /36

Attach the column-3 (with Enclosure converter) to the bottom frame.

M5 × 30 Screw × 2



1:1



Column-3 (with Enclosure converter) × 1

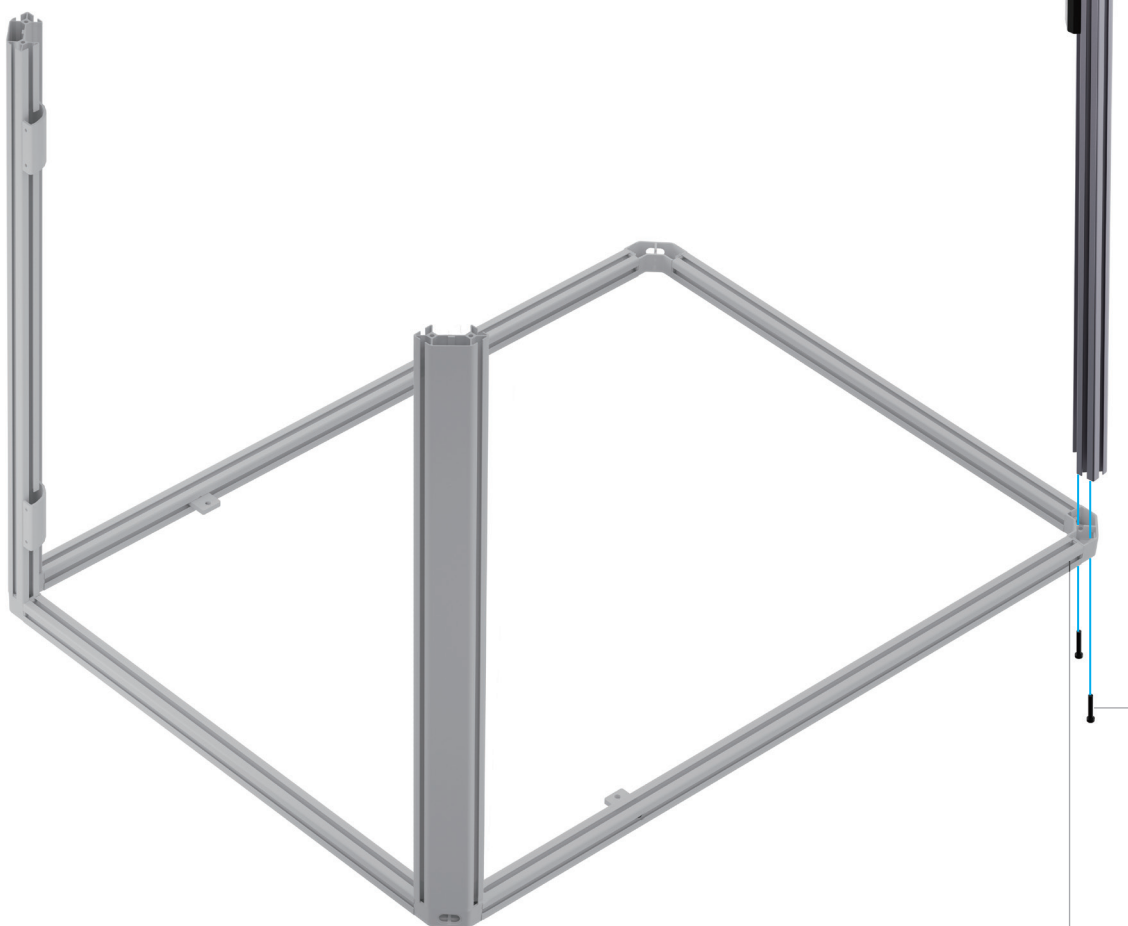

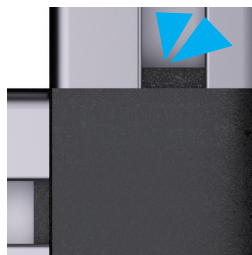

Make sure the alignment tabs of the profile connectors are inside the column grooves.

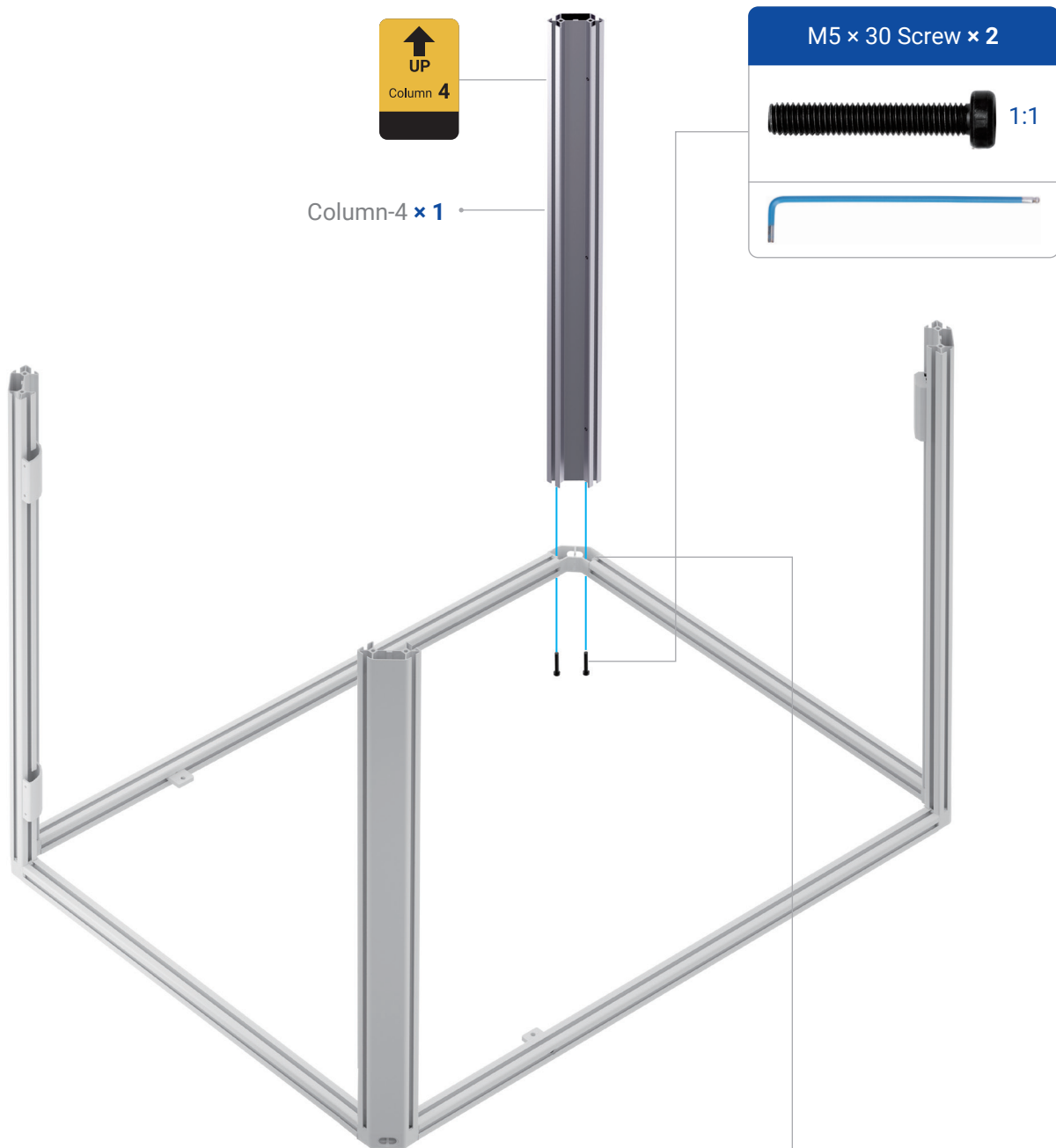

08 /36

Attach the column-4 to the bottom frame.



 Make sure the alignment tabs of the profile connectors are inside the column grooves.

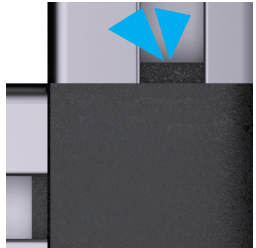

09 /36

Check the illustrated features to ensure that all the beams and columns are installed correctly.

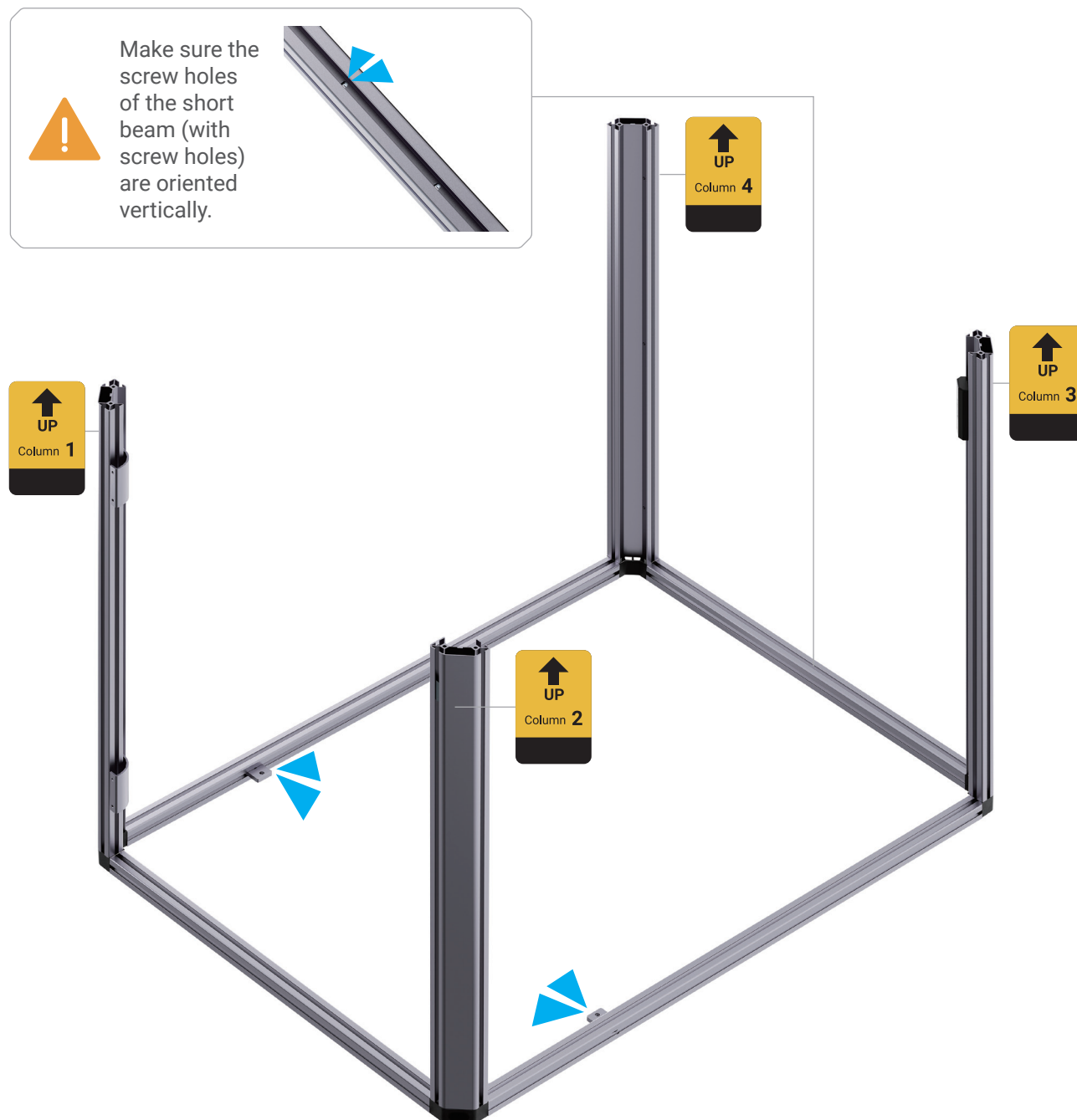

Make sure that the alignment tabs of the profile connectors are inside the grooves of the beams and columns.





Great job!
Let's install the top panel kit.

The midpoint line is ahead!

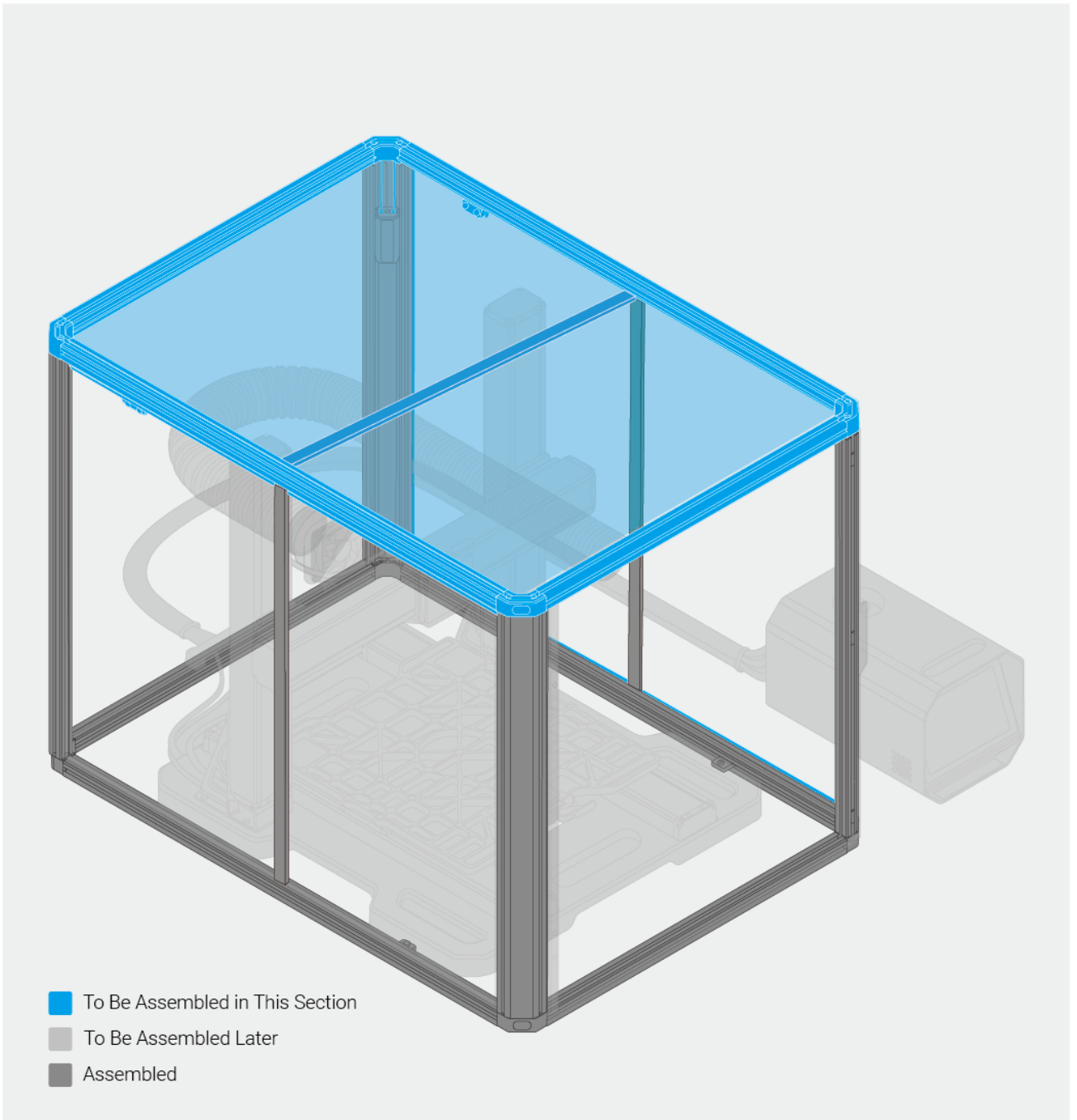

10_{/36}

Attach the two remaining profile connectors to the two long beams (with tube holder).

M5 × 12 Screw × 2

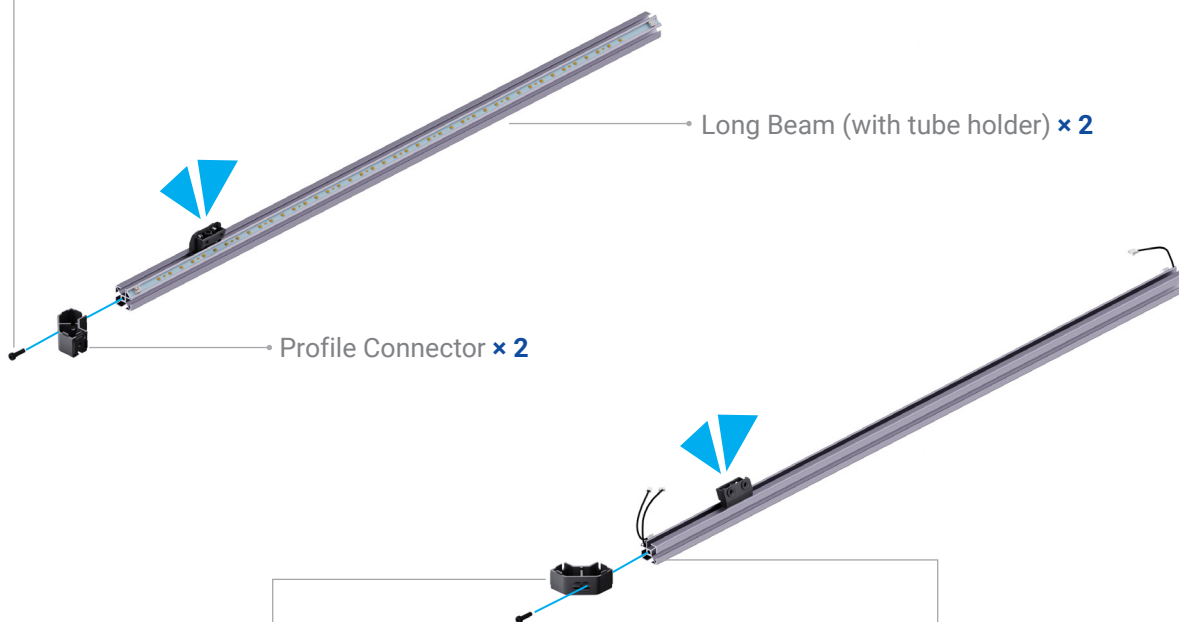

Make sure the two profile connectors are inside up.

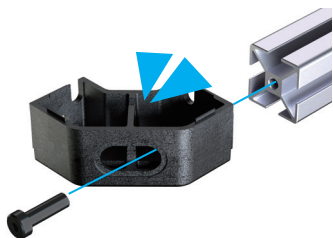

Make sure the alignment tabs of the profile connectors are inside the beam grooves.

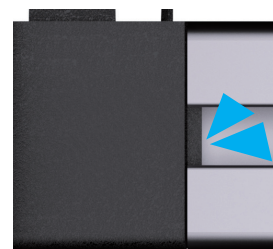



11 /36

Attach the short beam (with screw holes) to the profile connectors.



Make sure the closer pair of screws on the short beam are oriented vertically.



Make sure the alignment tabs of the profile connectors are inside the beam grooves.

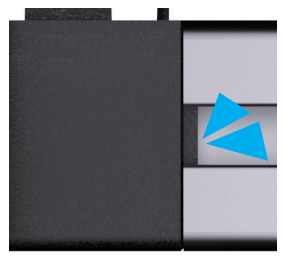



Make sure the strips and cables are not clamped between the beams.

12_{/36}

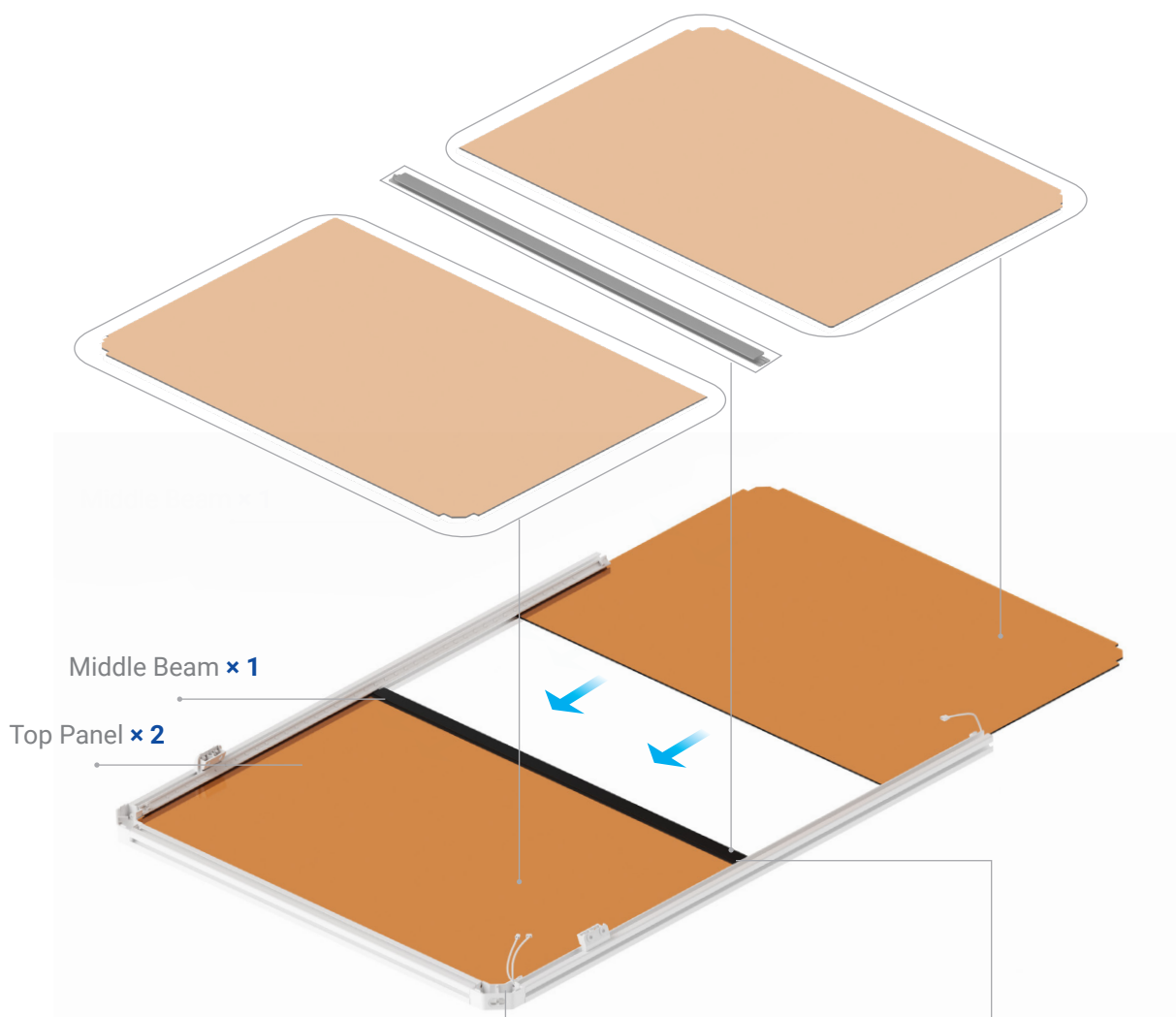
Insert one top panel into the top frame, then insert the middle beam and the other top panel.



 Make sure the cut corner of the top panel faces the profile connector.



 Make sure the shorter side of the middle beam is facing up.



13_{/36} Rotate the top panel kit horizontally for 180°. Then attach the short beam (with profile connectors) to the two long beams.

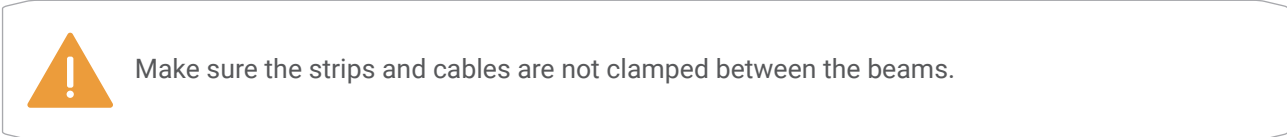
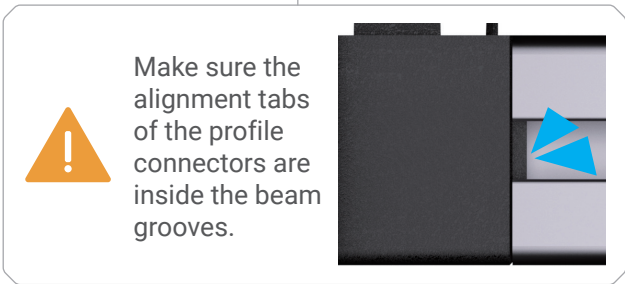
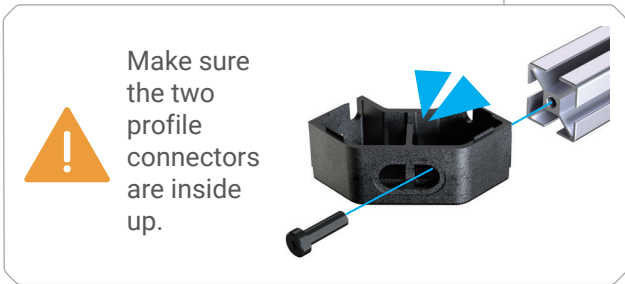
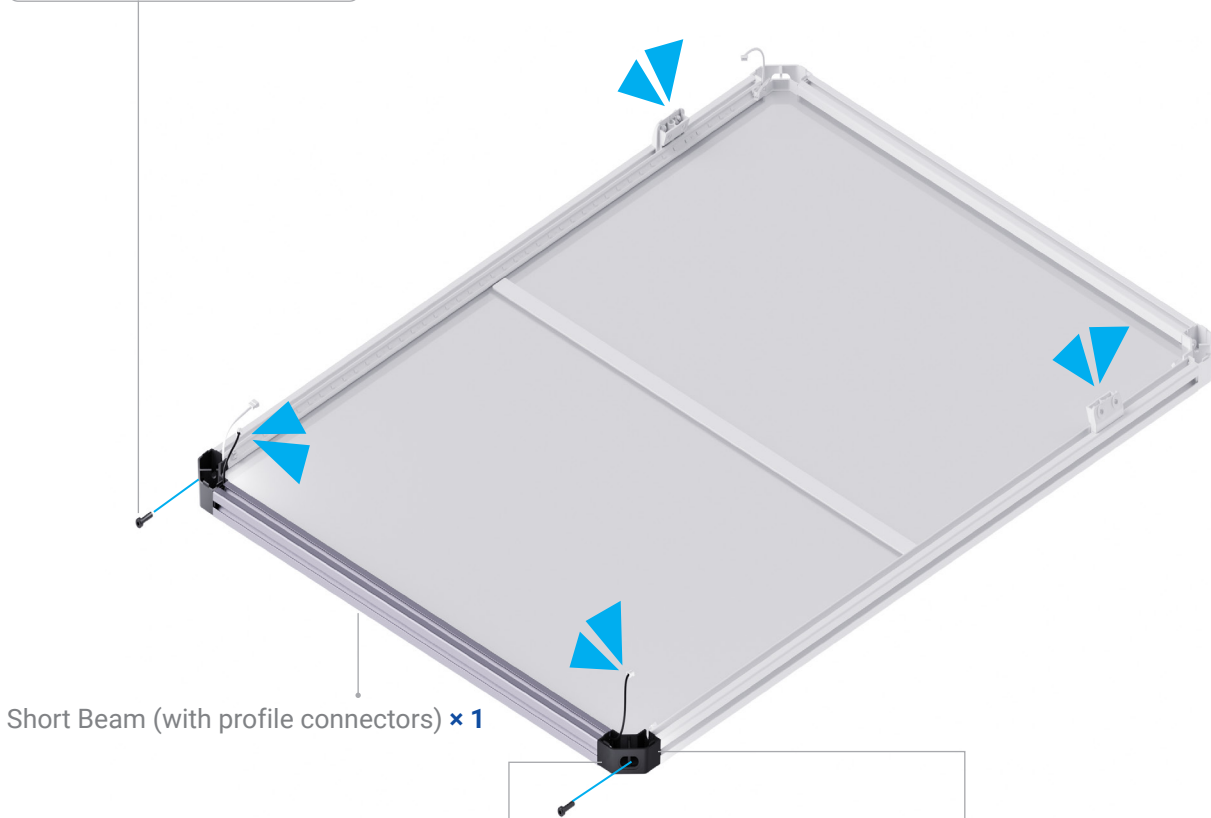

14_{/36}

Connect the two LED strips.

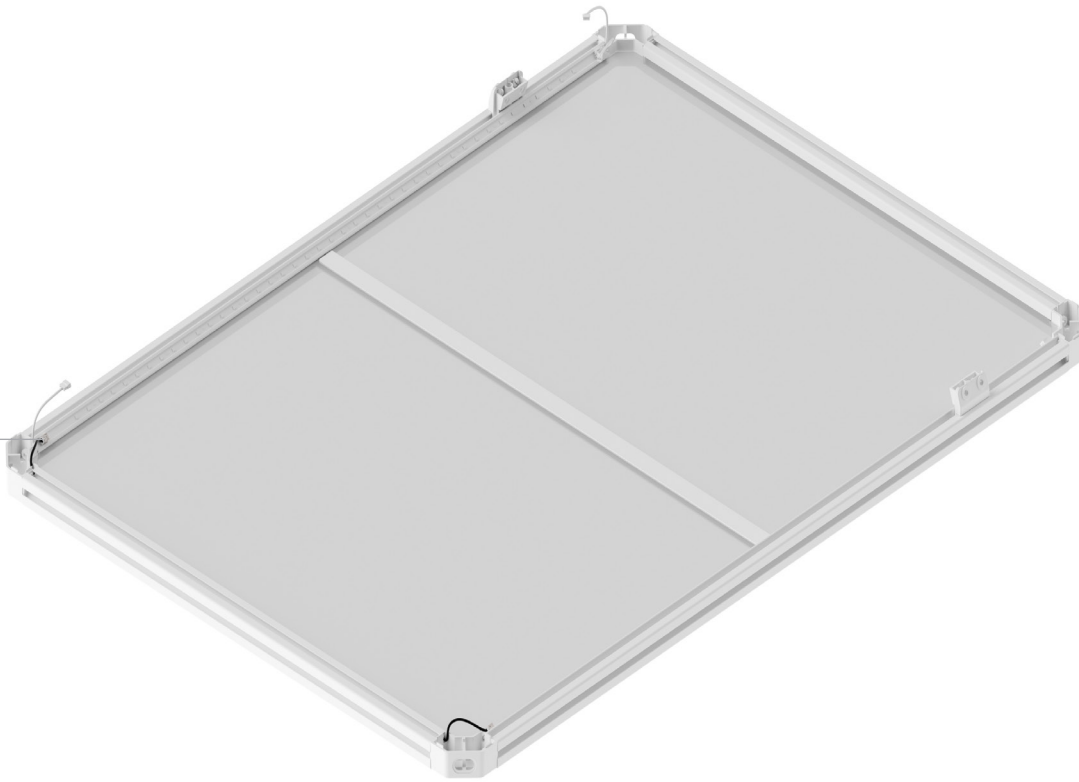

Make sure the connectors are in the correct direction.

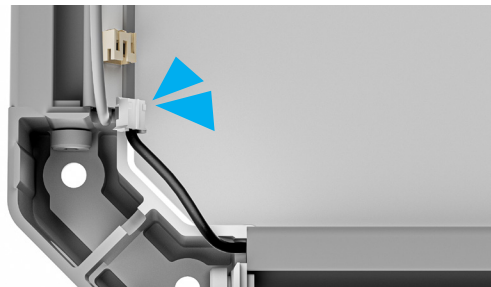

15_{/36}

Flip the top frame.

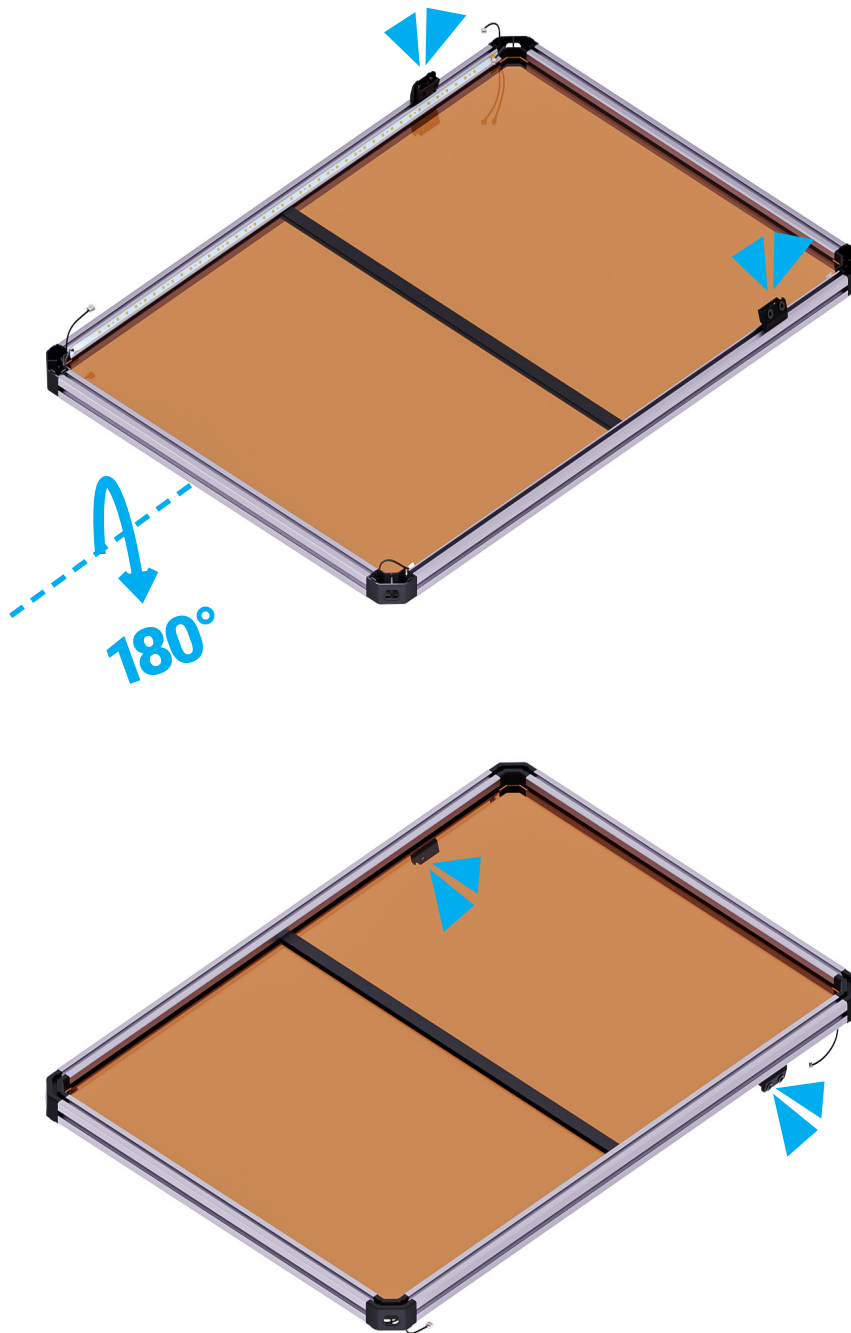

16_{/36}

Cut two narrow sealing strips and press them into the outer gaps between two top panels and the middle beam.

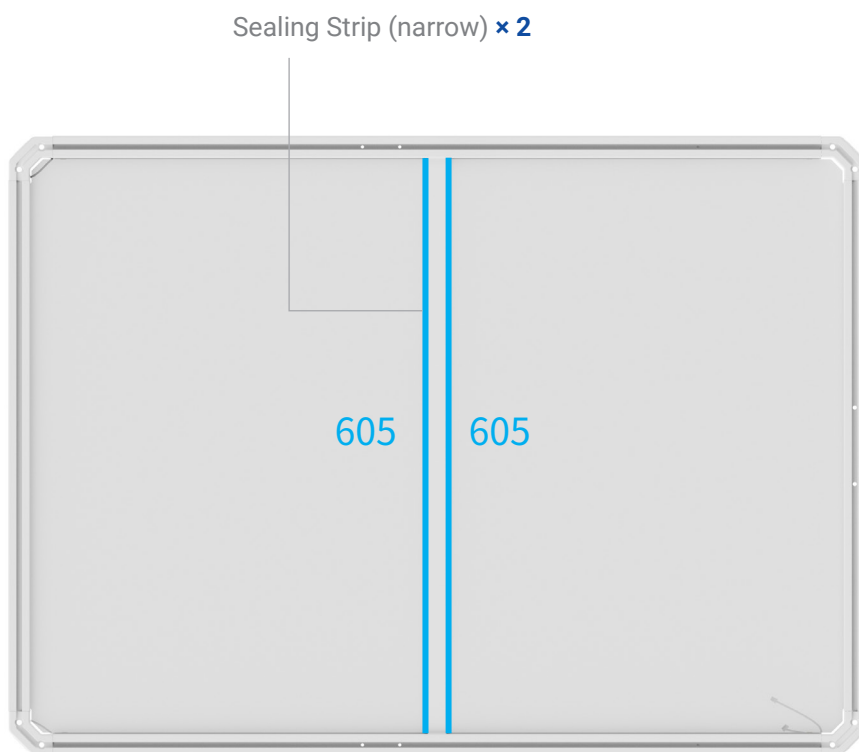

Measured in mm



Make sure to install the sealing strip correctly.

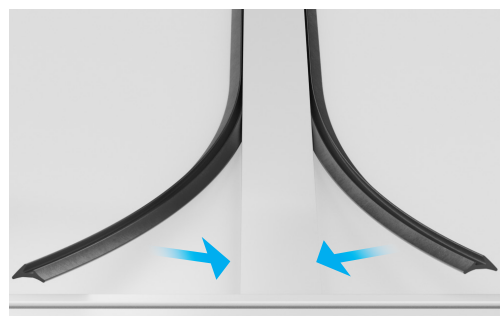
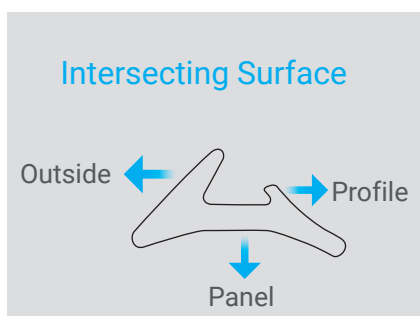

The sealing strips can help steady the panel in the frame.

17 /36

Cut six wide sealing strips and press them into the outer gaps between the two top panels and their adjacent profiles, respectively.

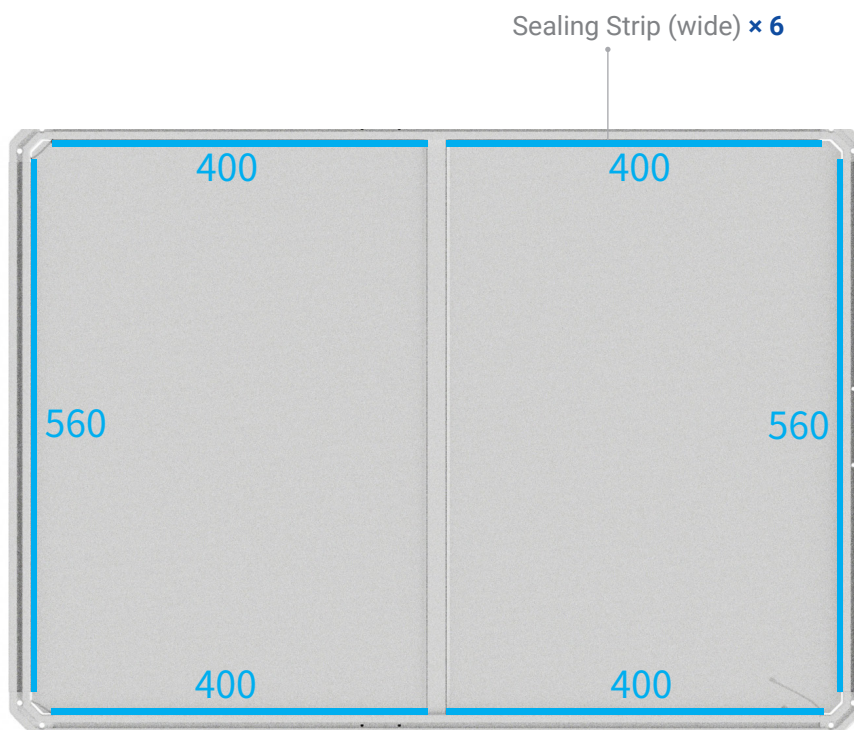

Measured in mm



Make sure to install the sealing strip correctly.

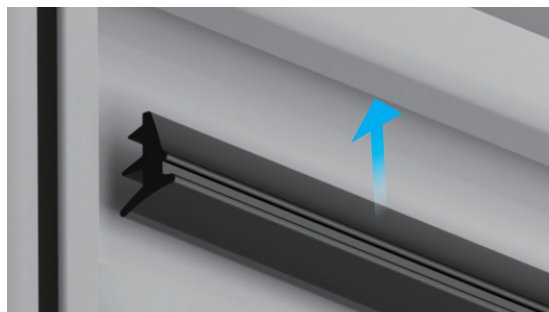
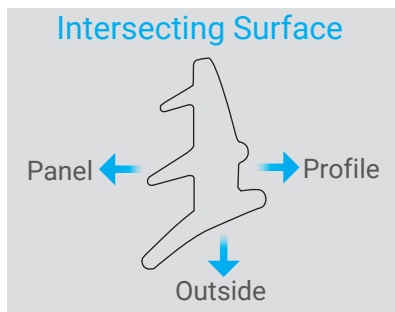





The sealing strips can help steady the panel in the frame.

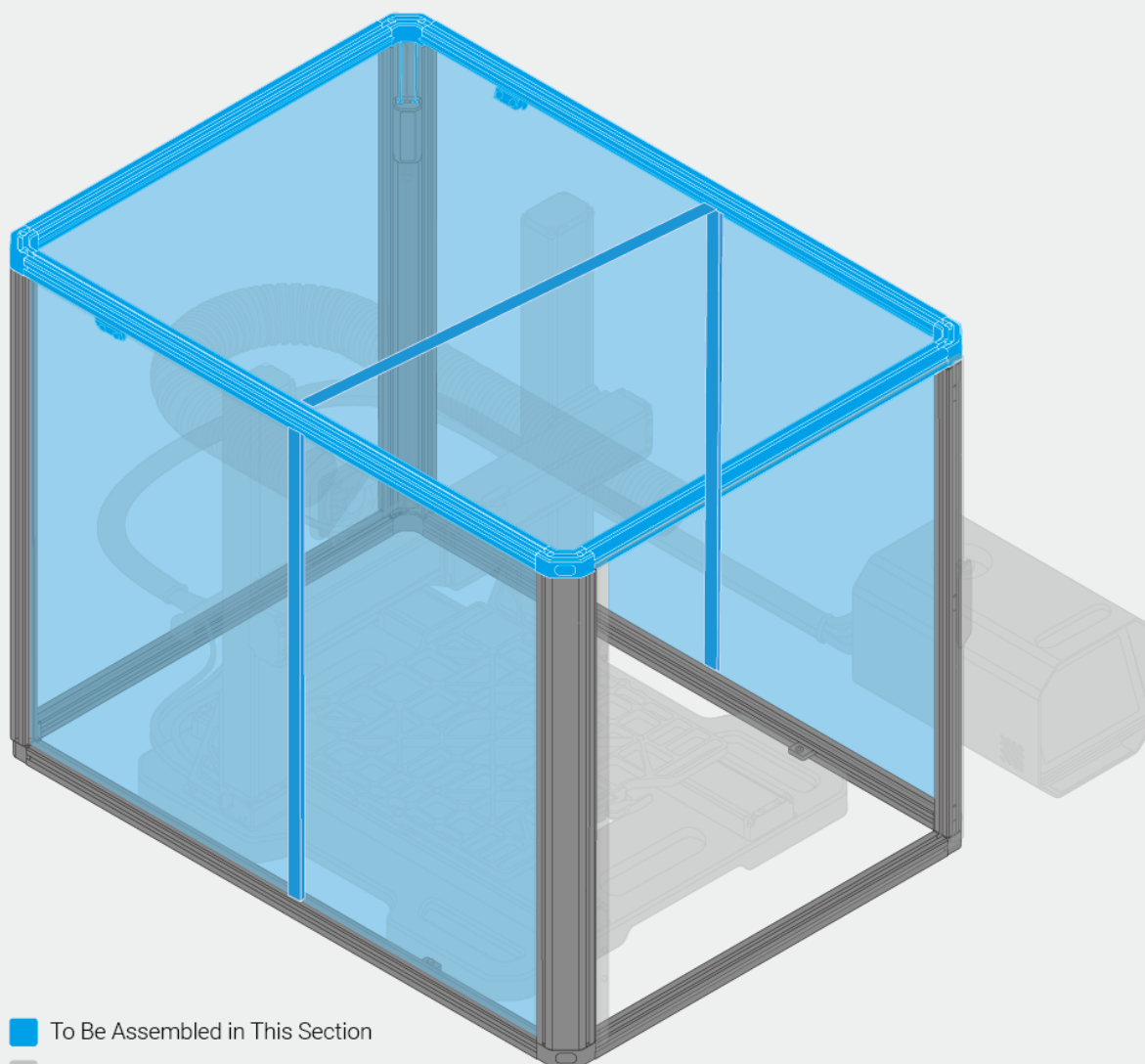

50% Achieved!

Take a break,
and start the second half of the game.



-  To Be Assembled in This Section
-  To Be Assembled Later
-  Assembled

18_{/36}

Insert the four side panels into the frame.

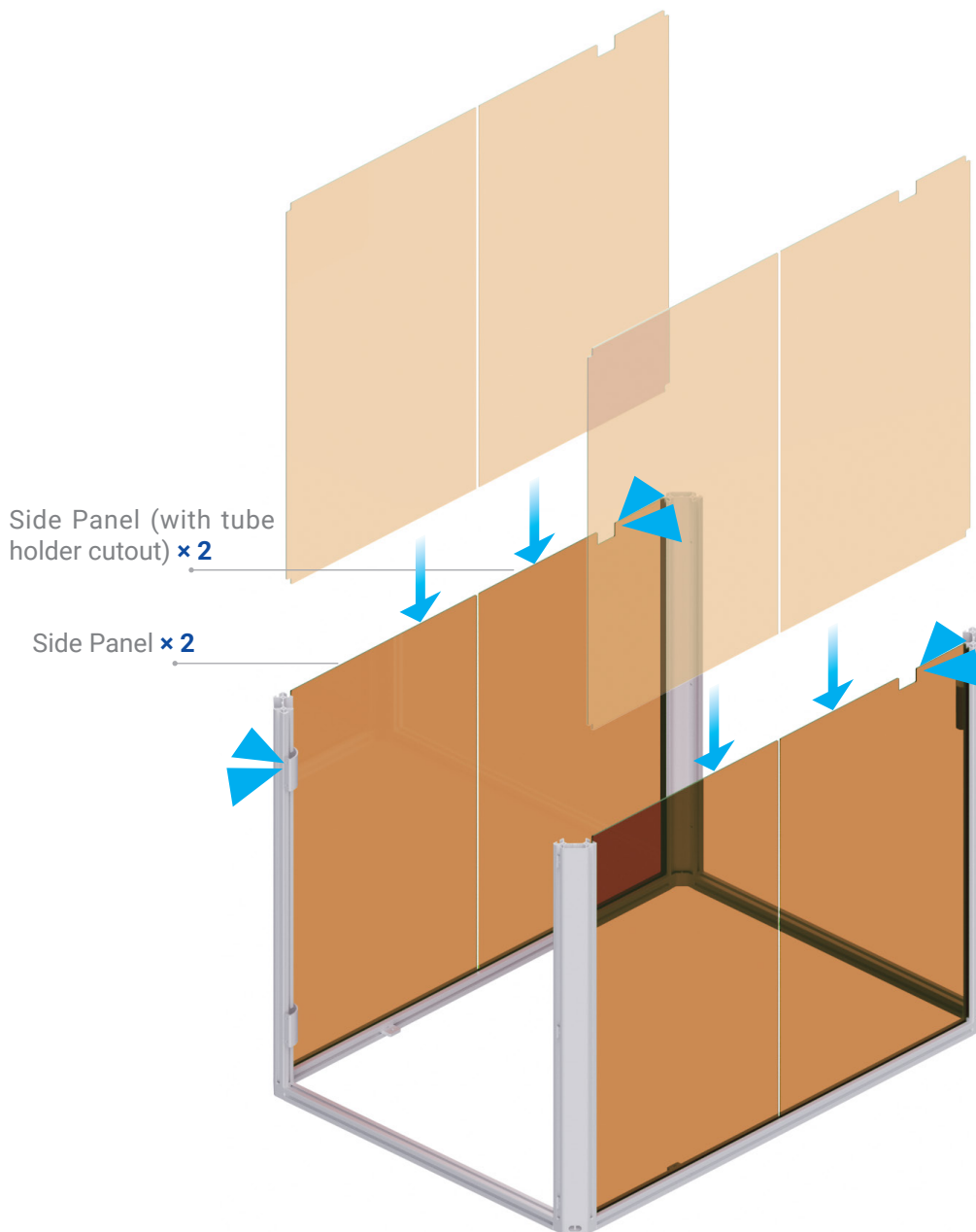

Make sure the left, right and bottom edges of the side panels are inserted into the grooves of the corresponding profiles.

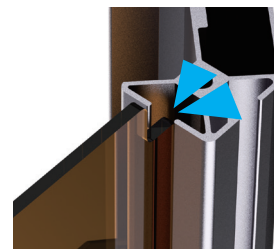

19_{/36}

Insert the two middle columns between the side panels.

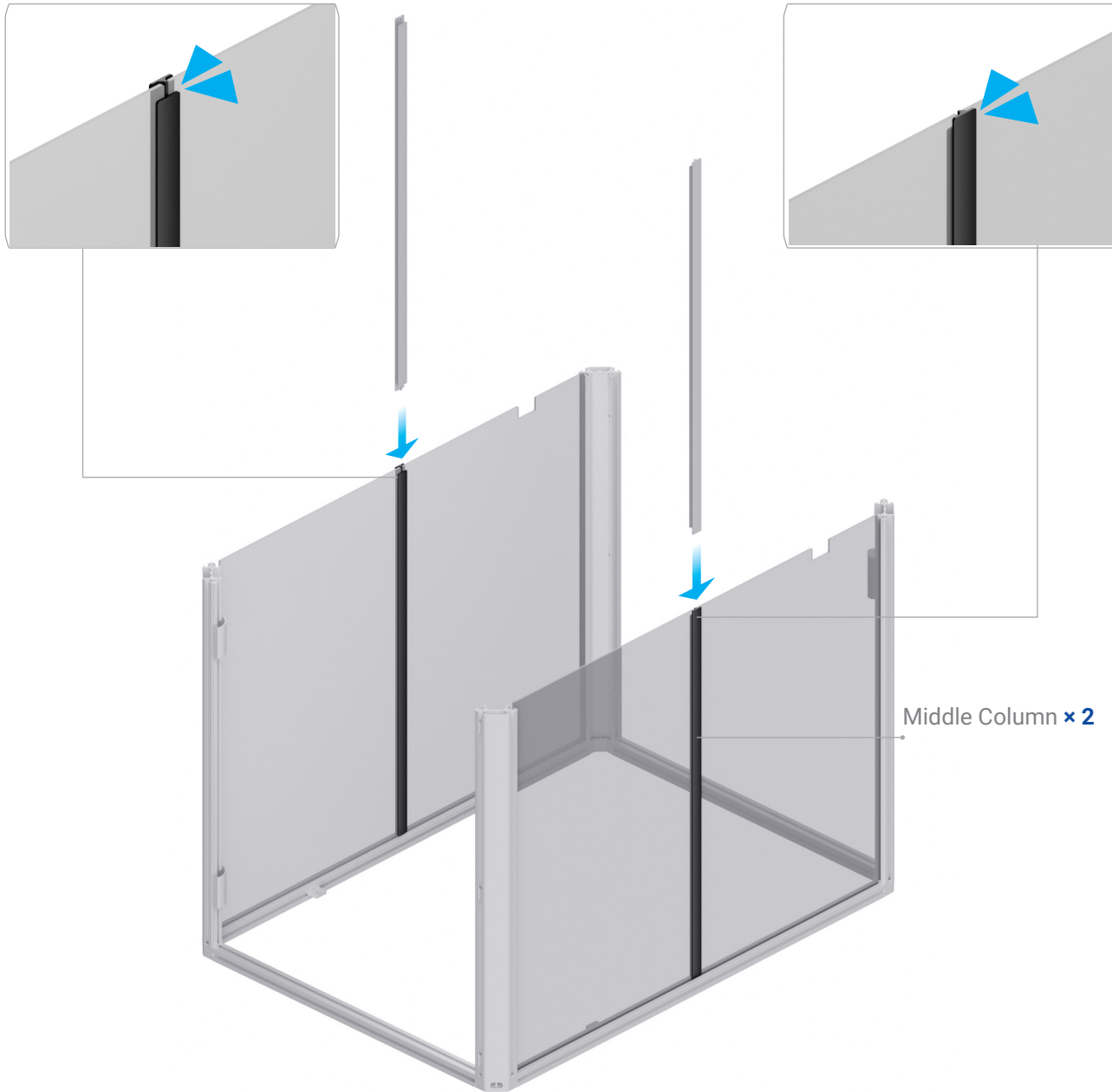

Make sure the longer side of the middle column facing outwards.

20_{/36}

Attach the top panel kit to the frame.

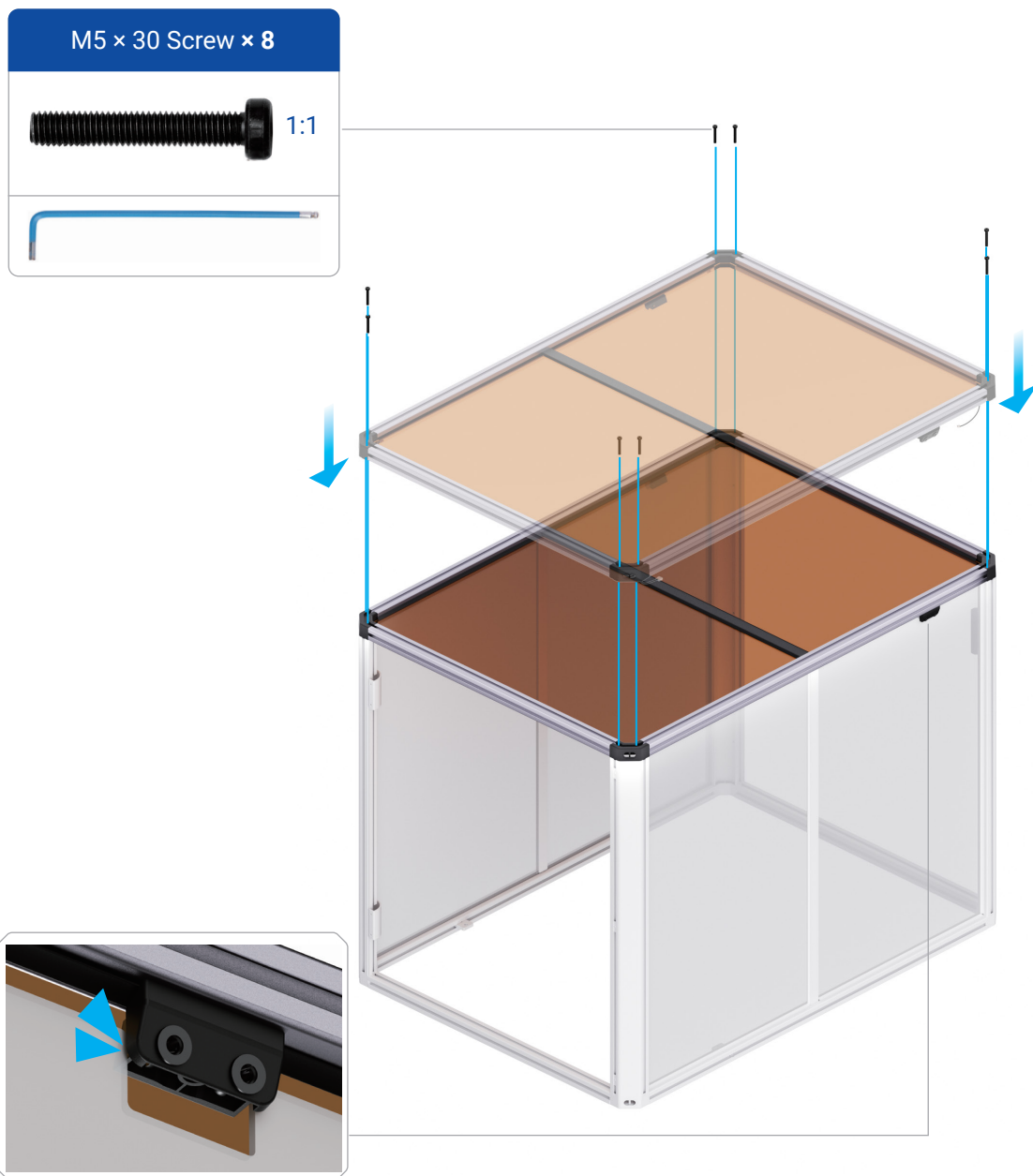

Make sure to insert the top edges of the side panels into the grooves of the corresponding beams.



It is recommended to pre-tighten all the screws first and then fully tighten them.

21 /36

Connect the LED strips and the hall switch to the Enclosure converter.

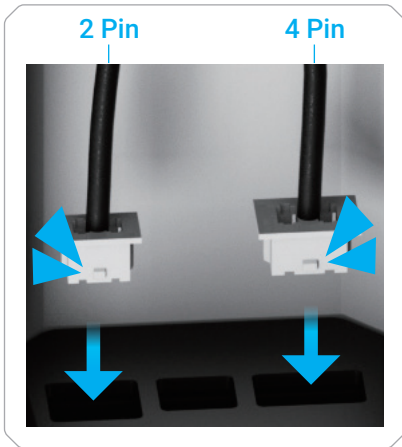
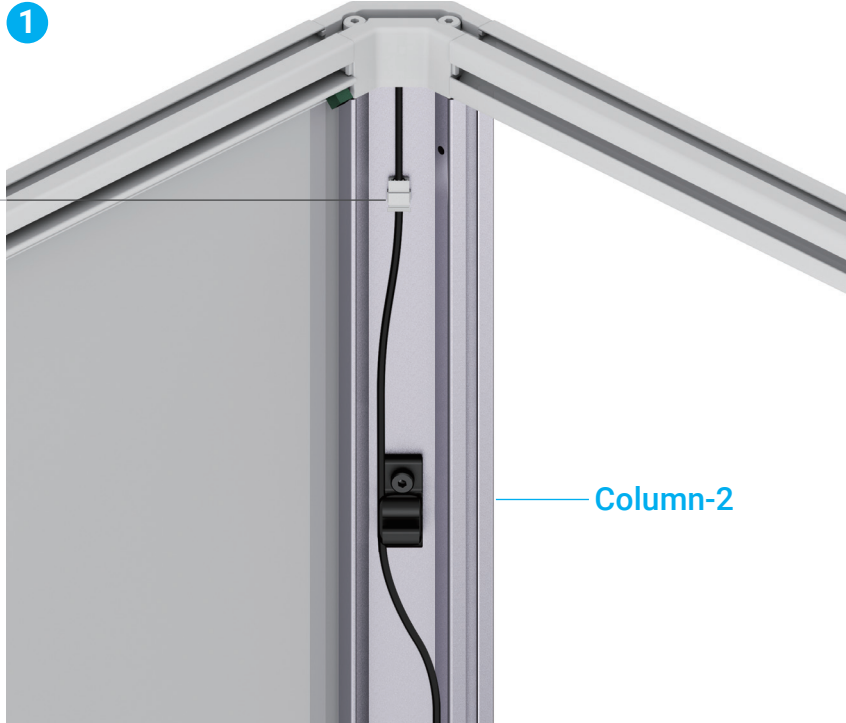
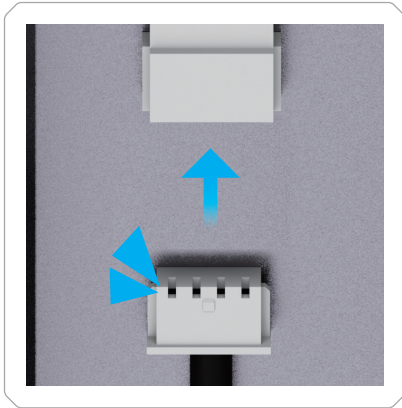

22_{/36} | Cut four narrow sealing strips and press them into the outer gaps between the side panels and the middle column.

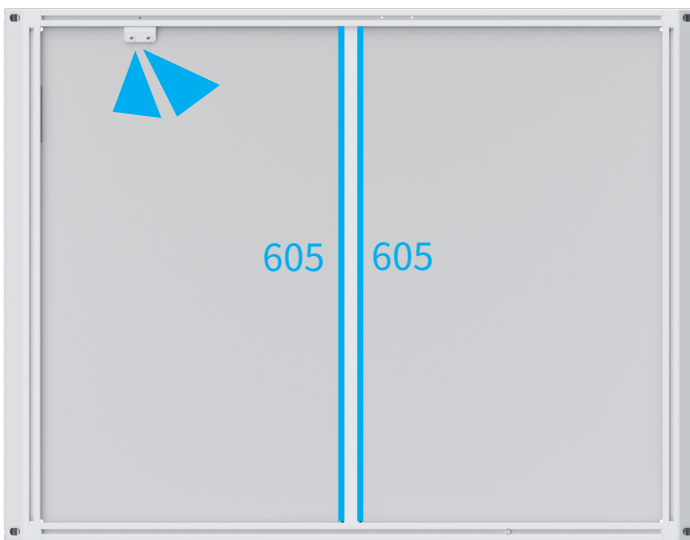
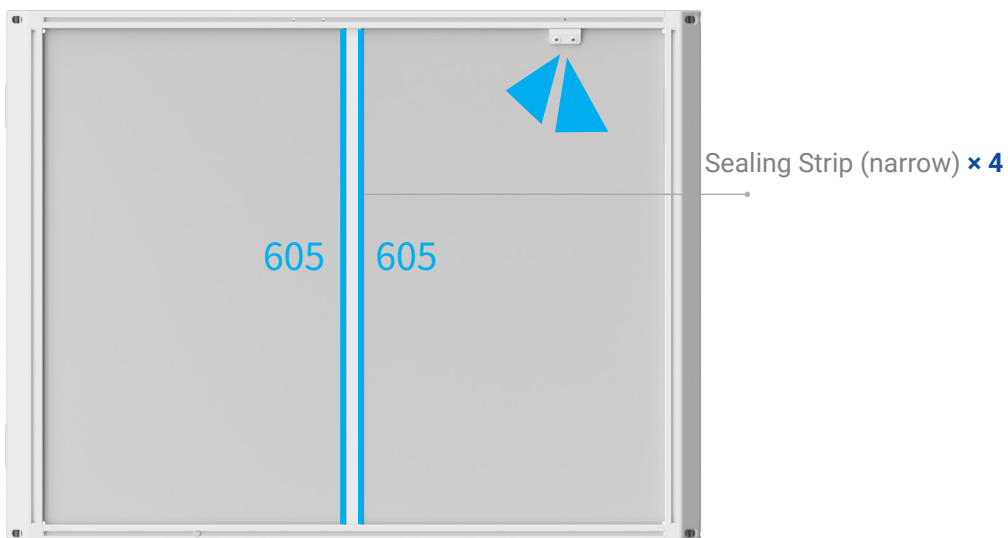

Measured in mm



Make sure to install the sealing strip correctly.

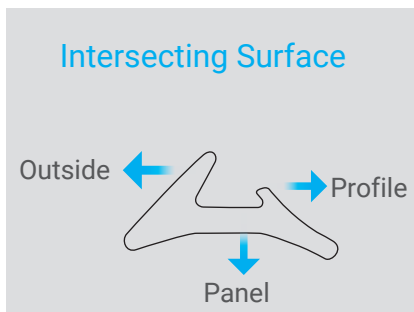

The sealing strips can help steady the panel in the frame.

23 /36

Cut fourteen wide sealing strips and press them into the outer gaps between the side panels and their adjacent profiles, respectively.

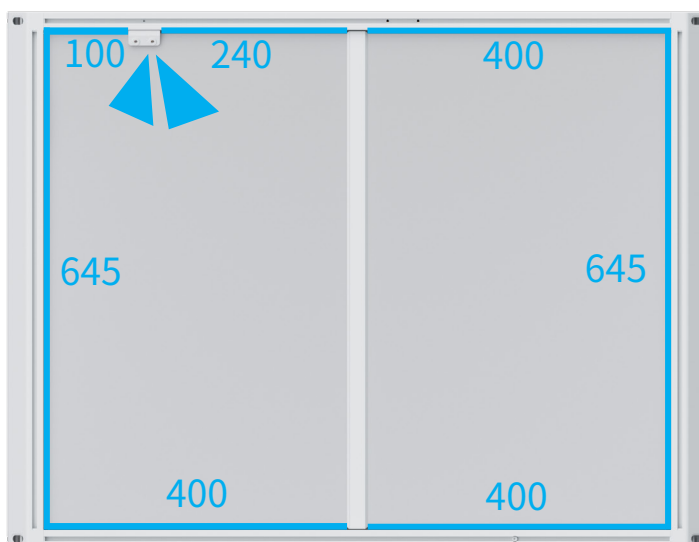
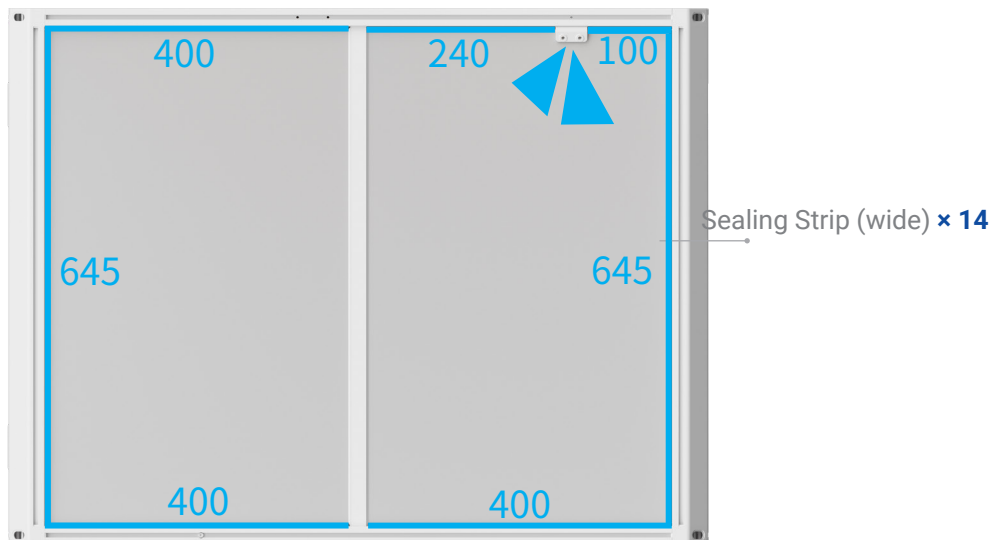

Measured in mm



Make sure to install the sealing strip correctly.

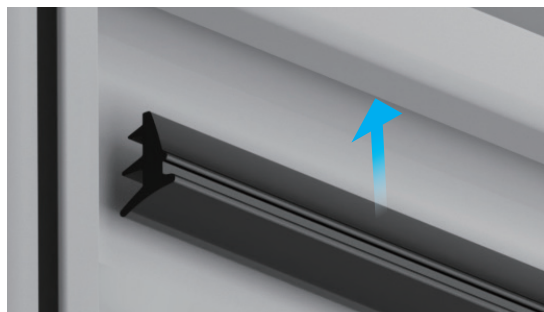
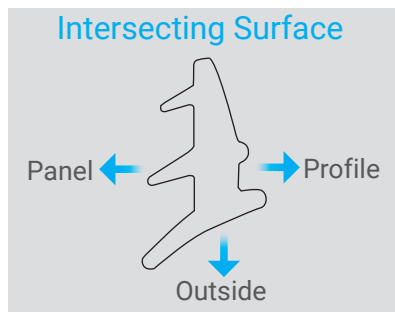

The sealing strips can help steady the panel in the frame.



Great job!

Let's install the Enclosure door and

Complete 70% of the race!

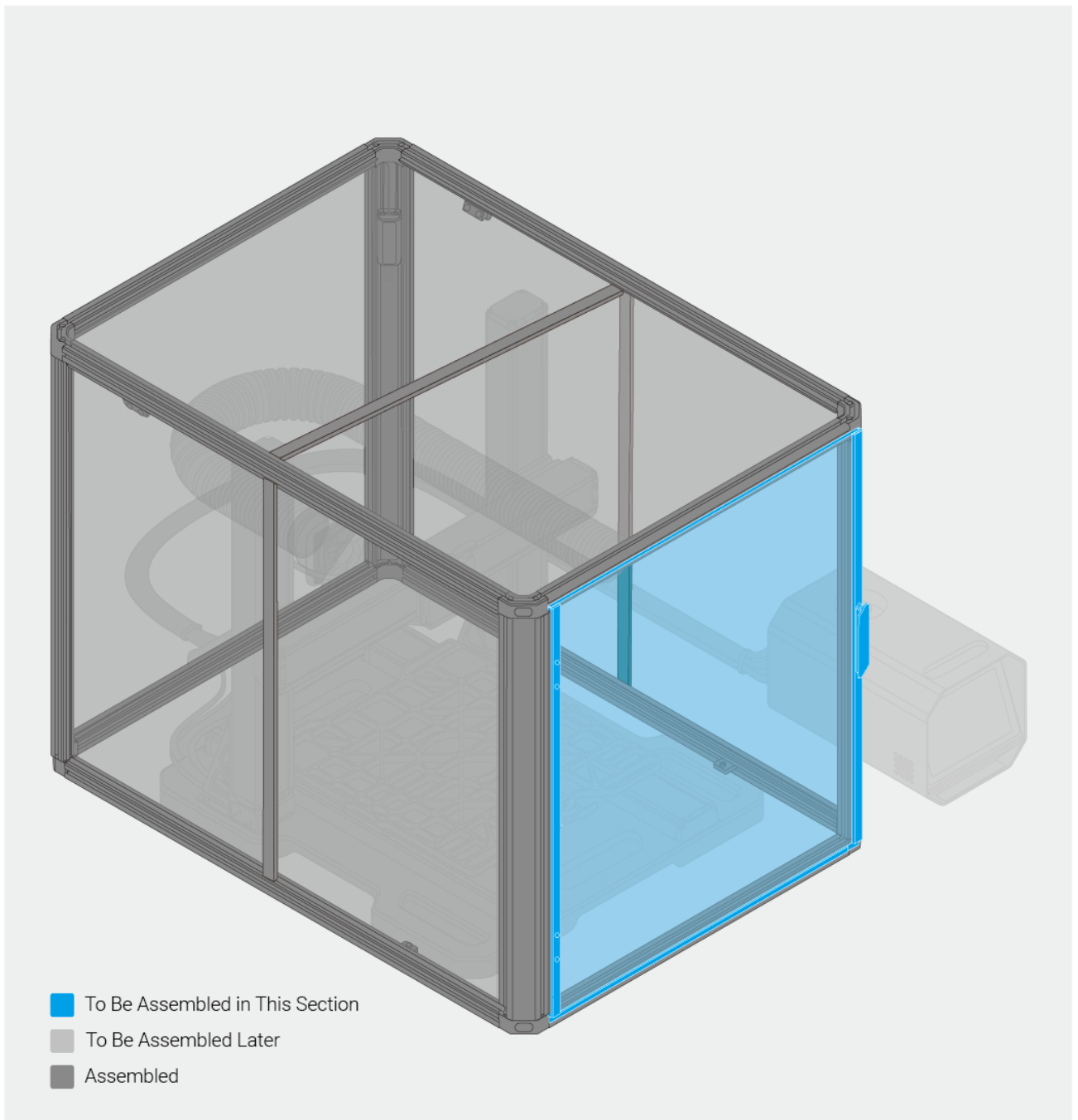

24_{/36}

Attach the Enclosure door to the frame.

M4 × 12 Flat Head Screw × 4

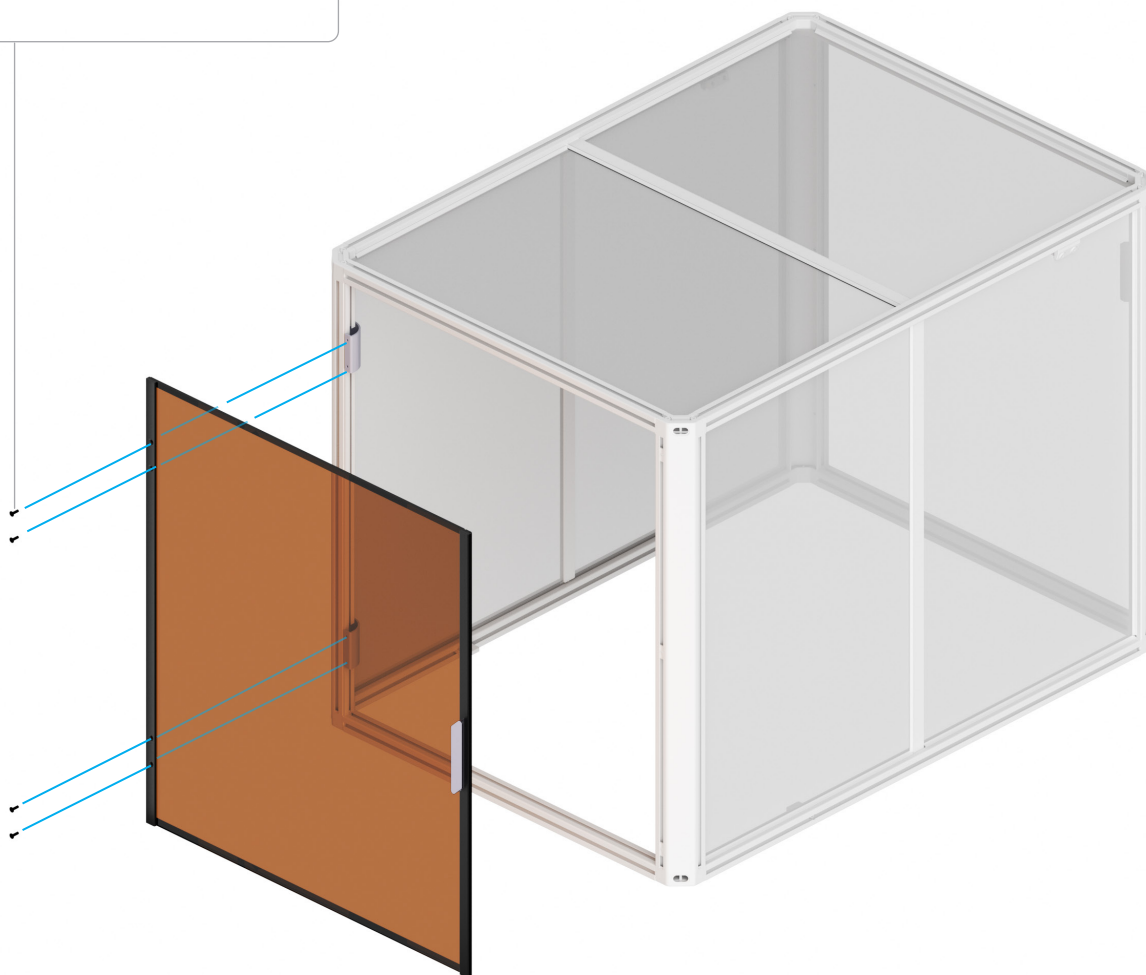

It is recommended to pre-tighten the uppermost and lowermost screws first, then pre-tighten the remaining screws, and finally tighten all the screws in the pre-tightening order.



Awesome!

Less than 30% left.

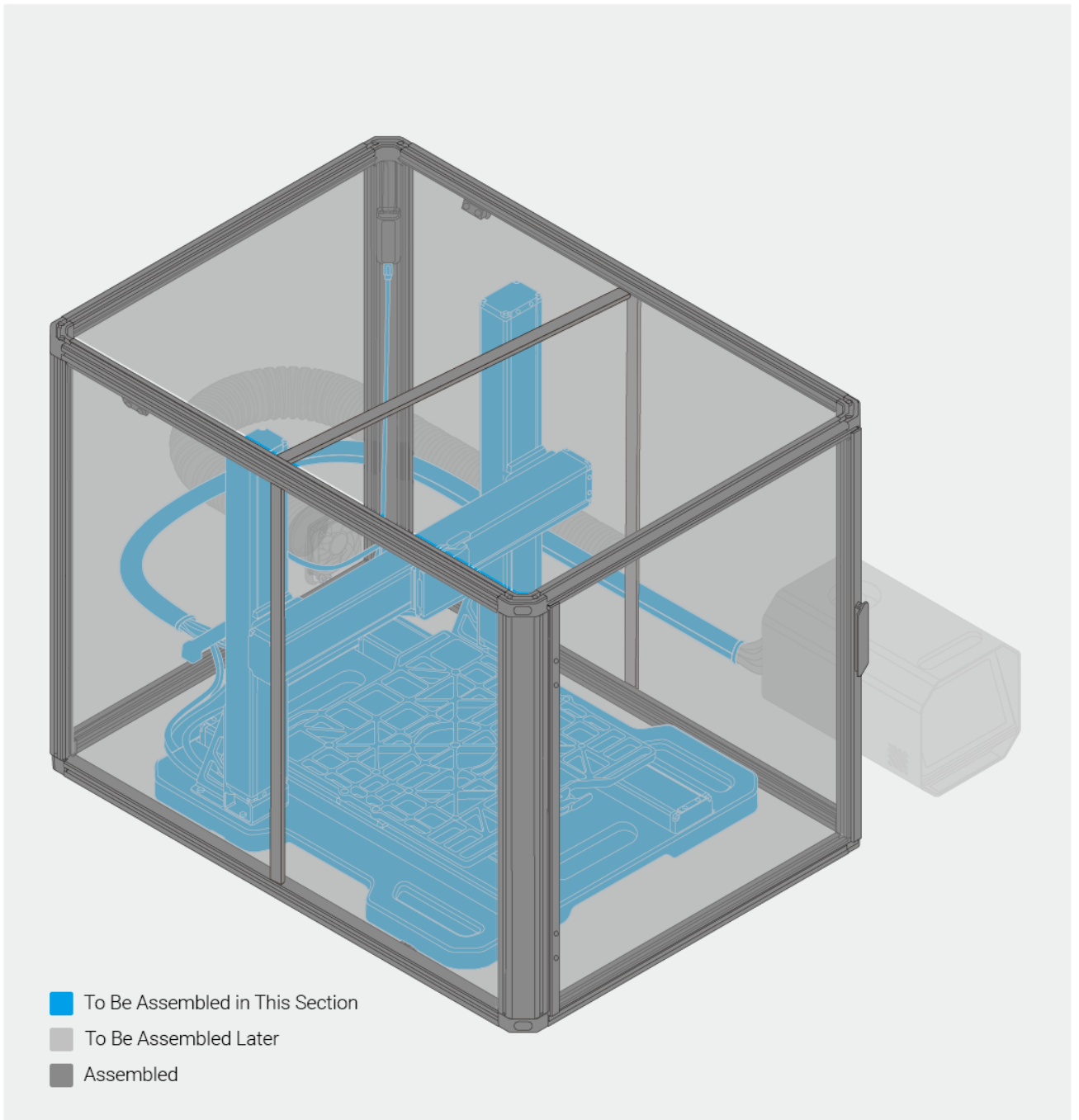

25_{/36}

Insert the two base fixtures (lower) underneath the left and the right sides of the base plate.

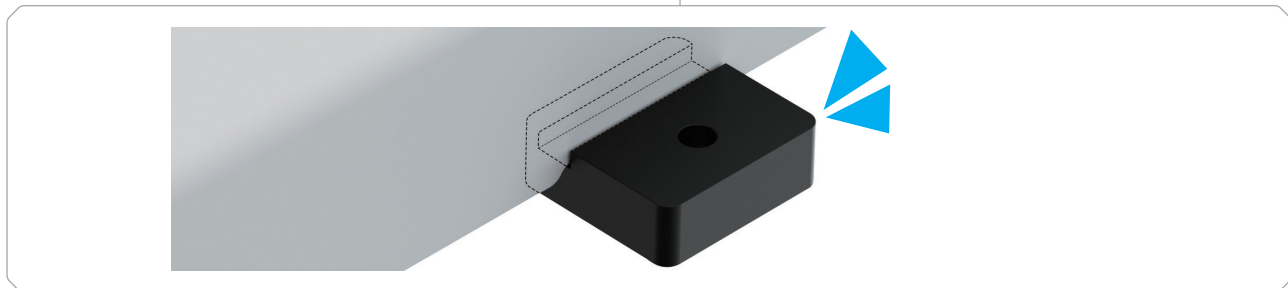
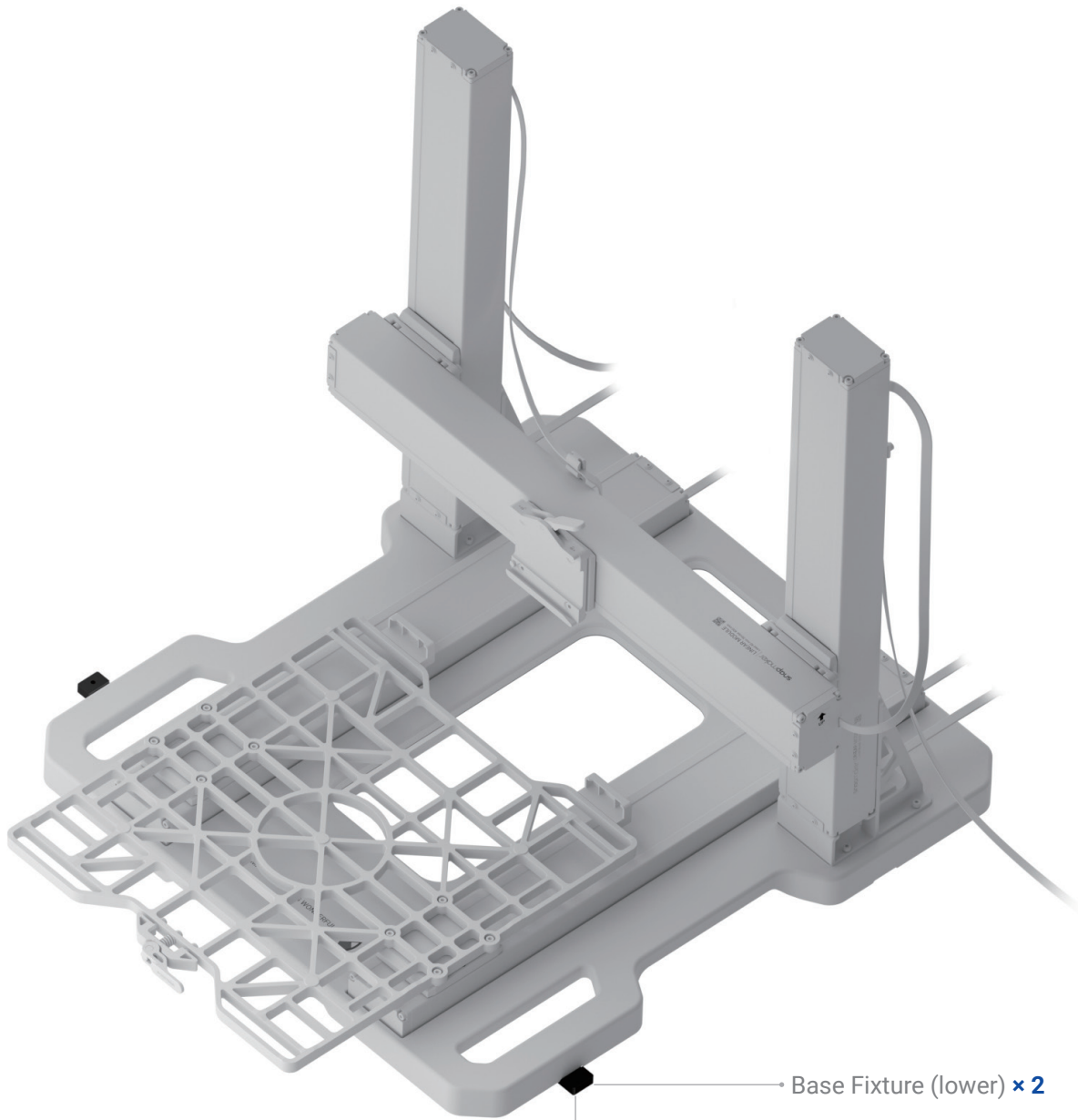

26_{/36}

Cover the machine with the Enclosure from above.

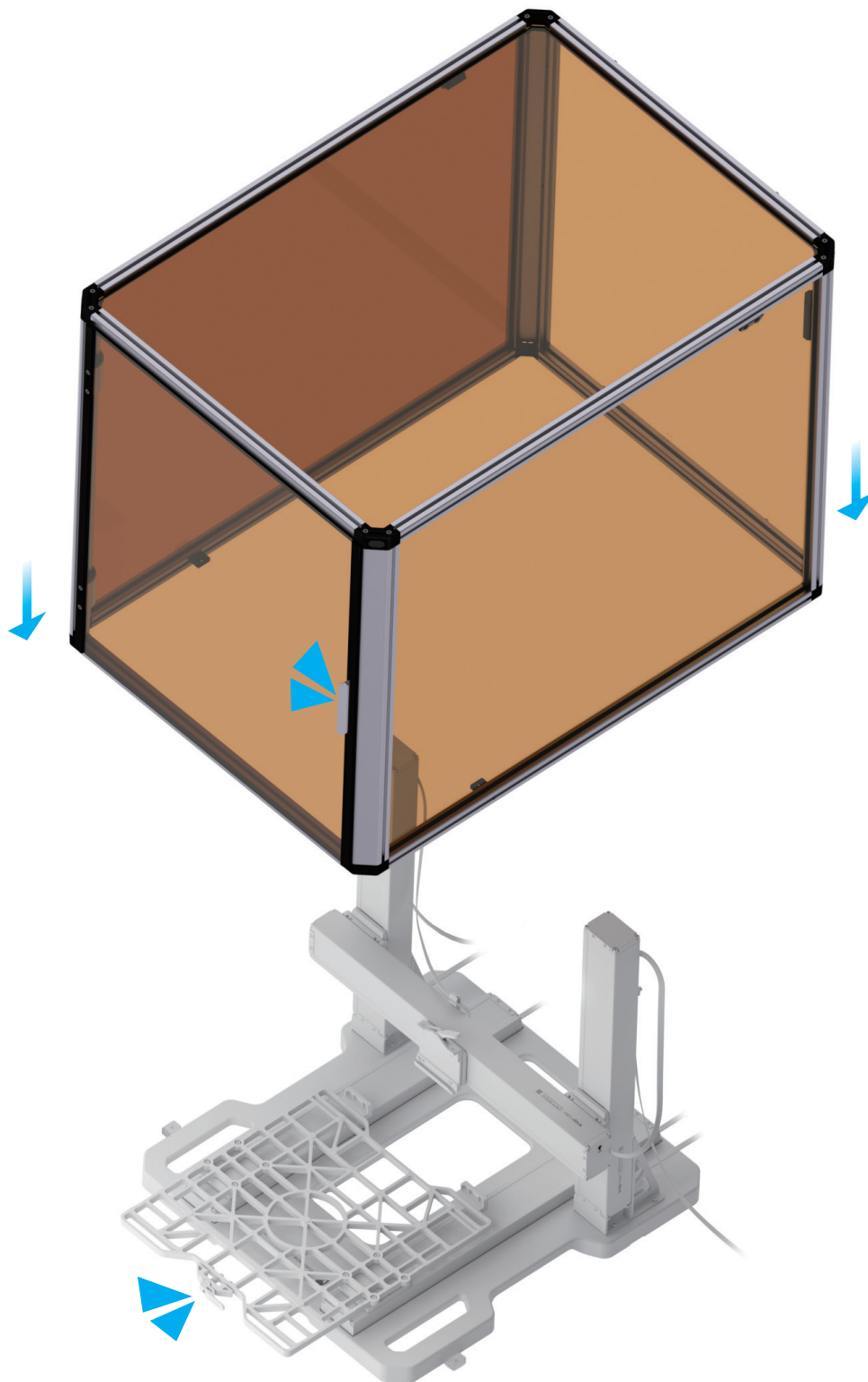

Although there are no middle beam and middle column in some of illustrations, the instructions are the same.



Make sure the Enclosure does not collide with the machine while moving. It is recommended that at least two people operate together.

27 /36

Plug the Enclosure cable into the Enclosure converter.



Enclosure Cable x 1

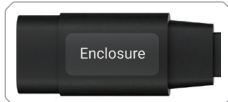

Ensure that the connector is in the correct direction.

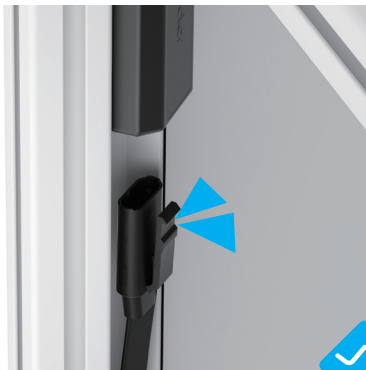

28_{/36}

Gather the cables with the cable collector.



29 /36

Thread the cables through the corresponding hole of the cable pass-through fixture, and then attach the fixture to the short beam (rear).

M5 × 30 Screw × 2

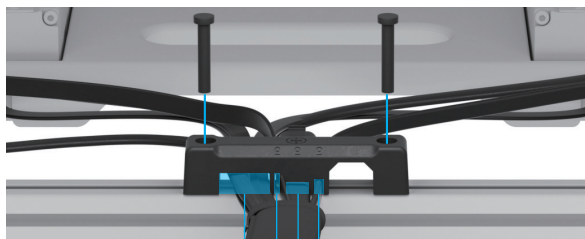
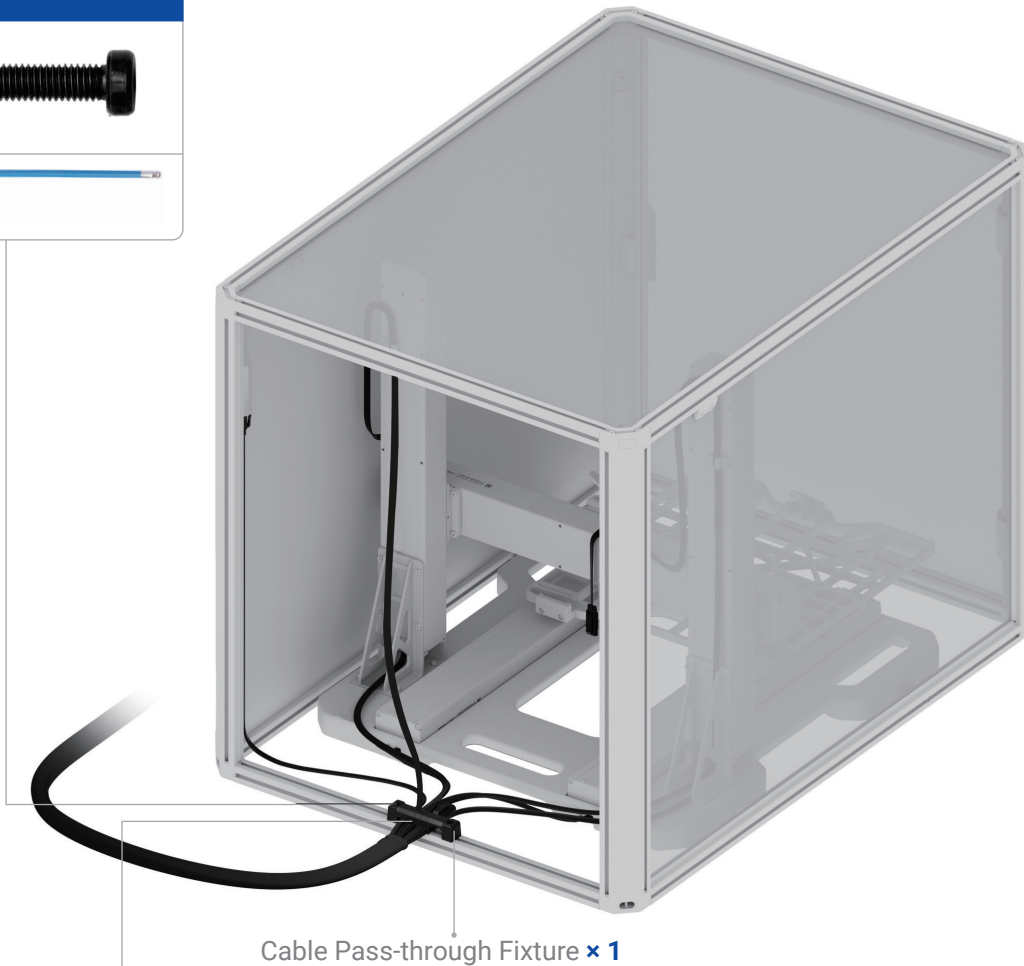

Other Cables X-axis Cable Heated Bed Cable Toolhead Cable



Ensure that the three yellow locating labels are all underneath the cable pass-through fixture.

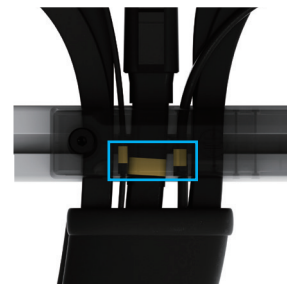

Whether or not the first function you will experience is 3D printing, you need to thread the heated bed cable through the cable pass-through fixture in this step.



The rightmost cable hole is reserved for the extension cable of the Rotary Module (for 4-axis machining), which is available for purchase on our online store.



Great job!

The destination is in sight!

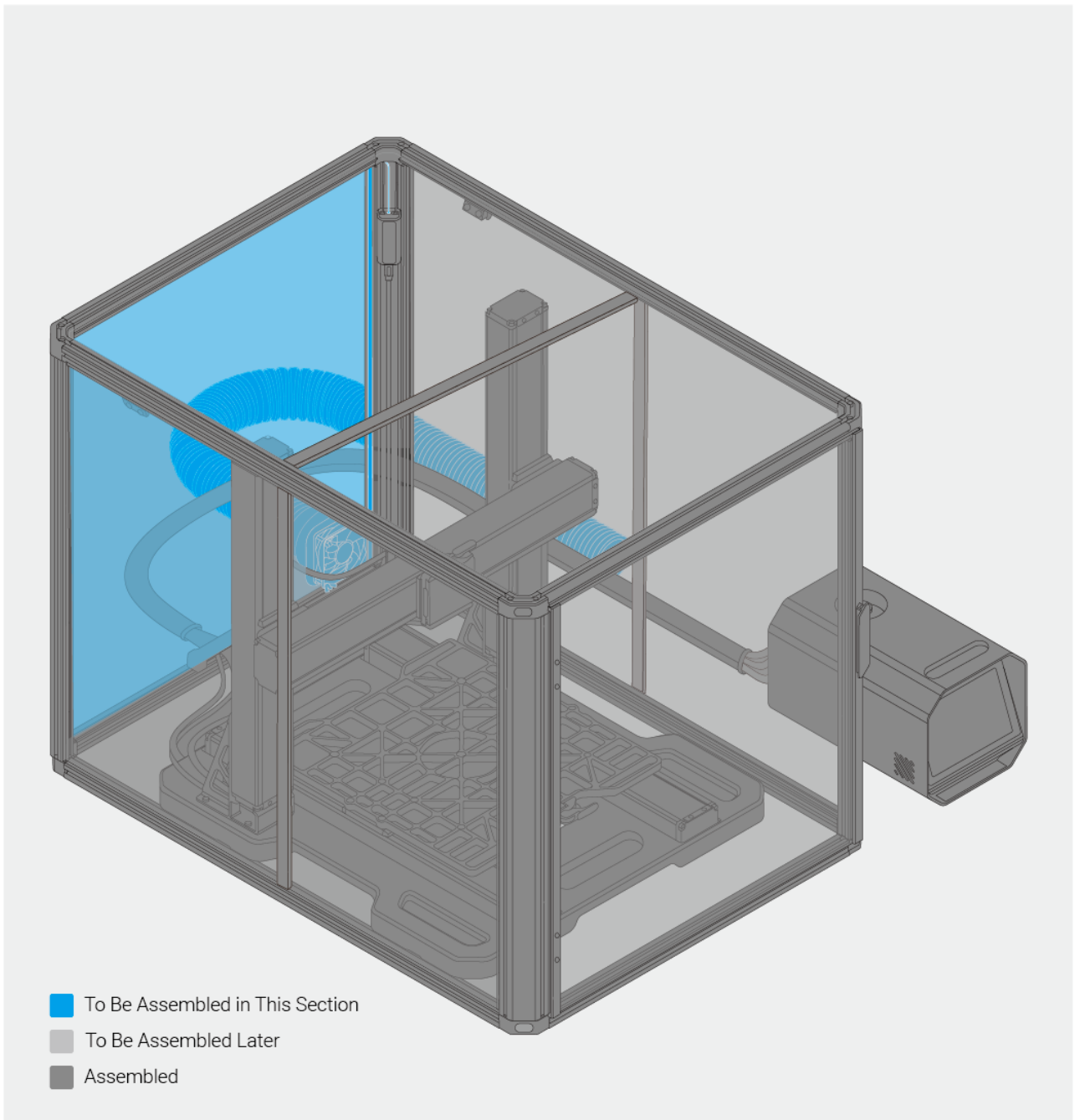

30 /36

Attach the exhaust fan guard, the boosted exhaust fan and the hose connector to the back panel.

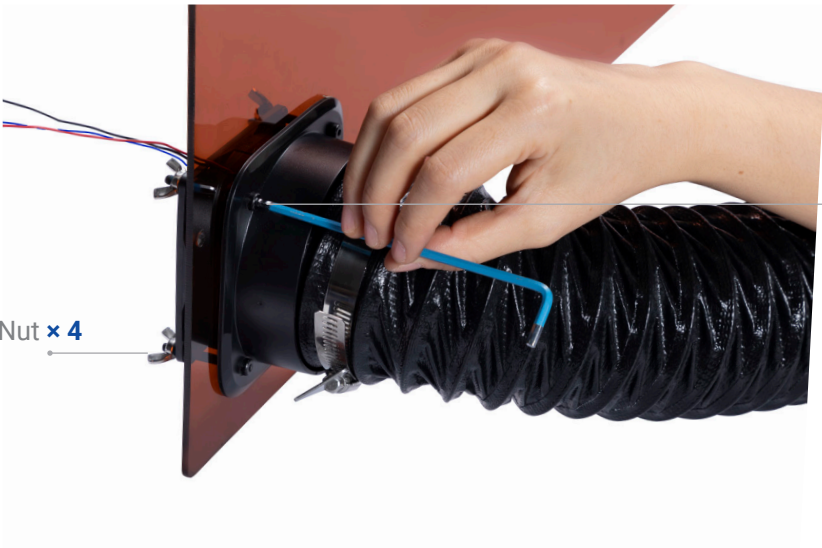
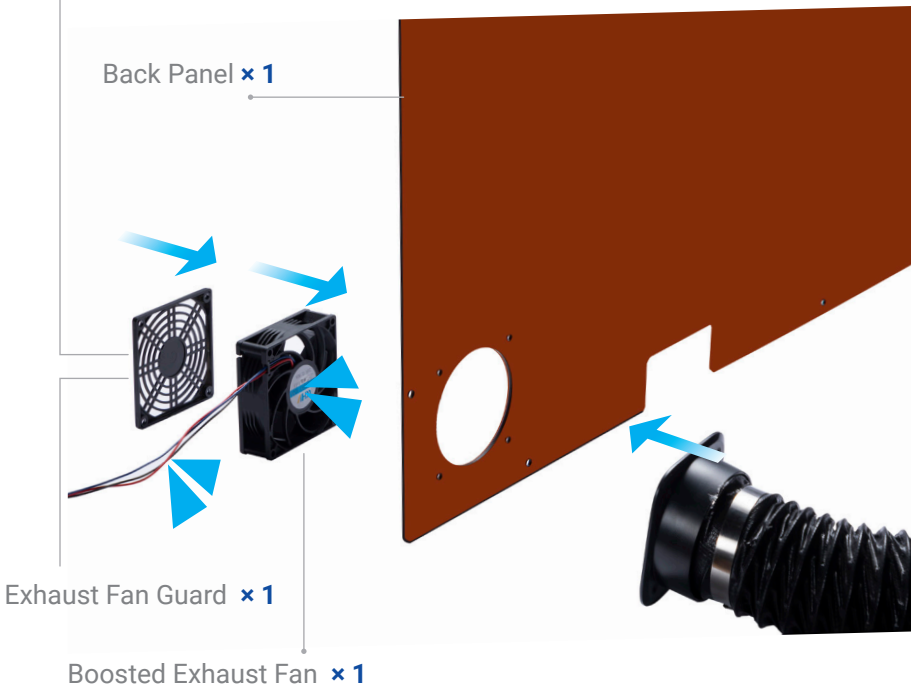
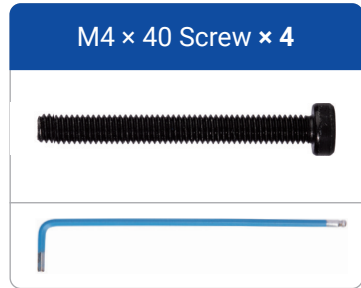
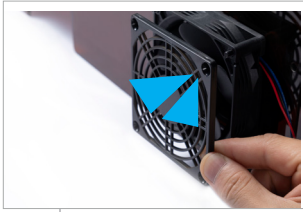

31 /36

Connect the exhaust fan to the Enclosure converter. Then, cut a suitable length of the cord collecting strip to bury the exhaust fan cord into the column groove.

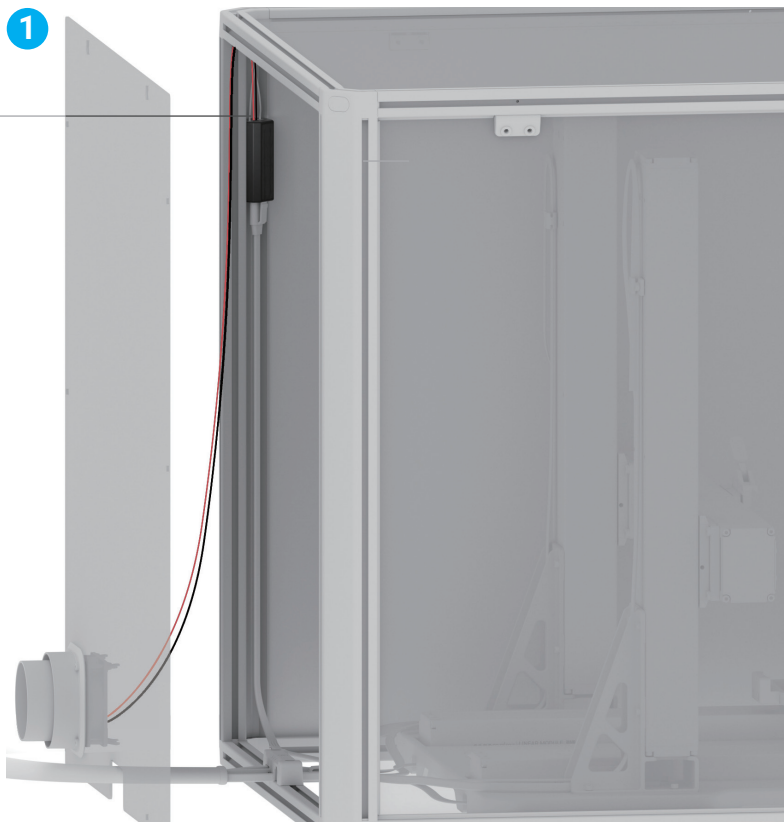
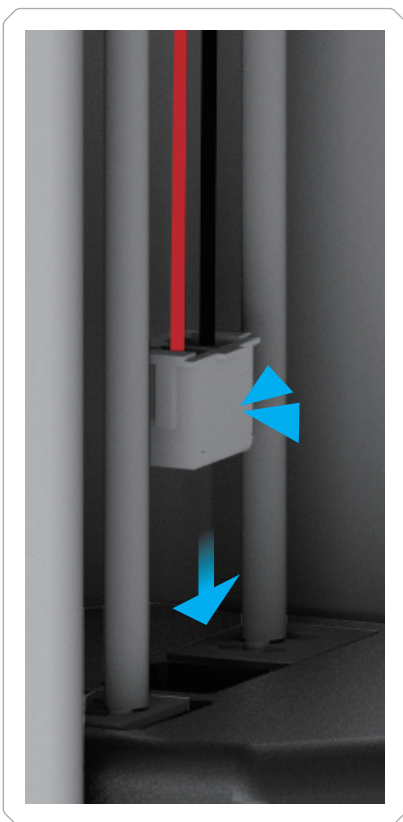

32_{/36}

Attach the back panel to the frame.

M5 × 16 Low Head Cap Screw × 10

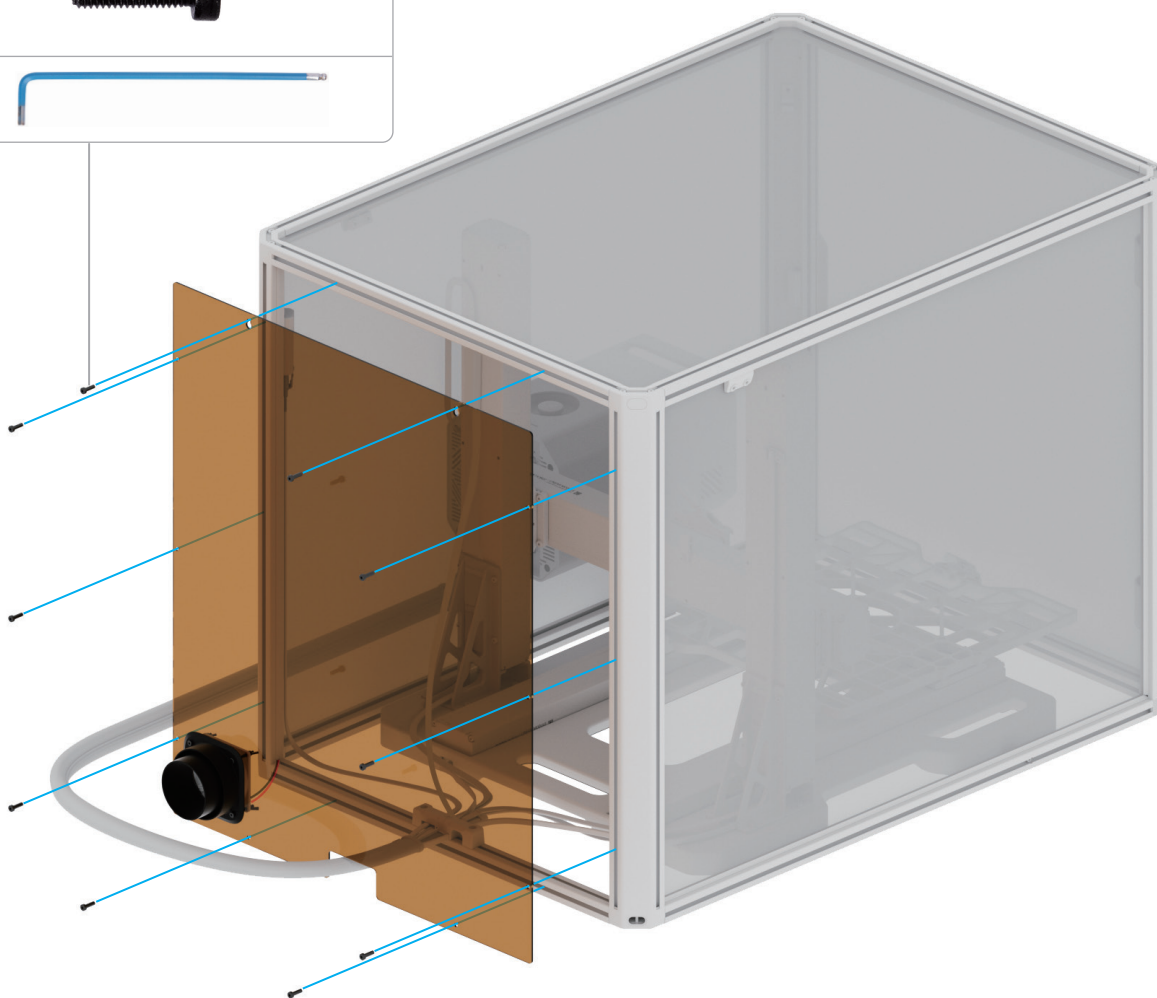

Do not over-tighten the screws lest the panel should be damaged.



It is recommended to pre-tighten the screws near the corners first, then pre-tighten the remaining screws, and finally tighten all the screws in the pre-tightening order.



You can install the two uppermost screws first, hang the back panel on them, and then install the other screws.

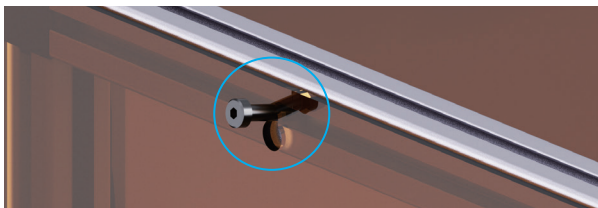

33 /36

Put the hose into the hose clamp and secure the hose to the hose connector as illustrated.





Hang on,
It's about to finish!

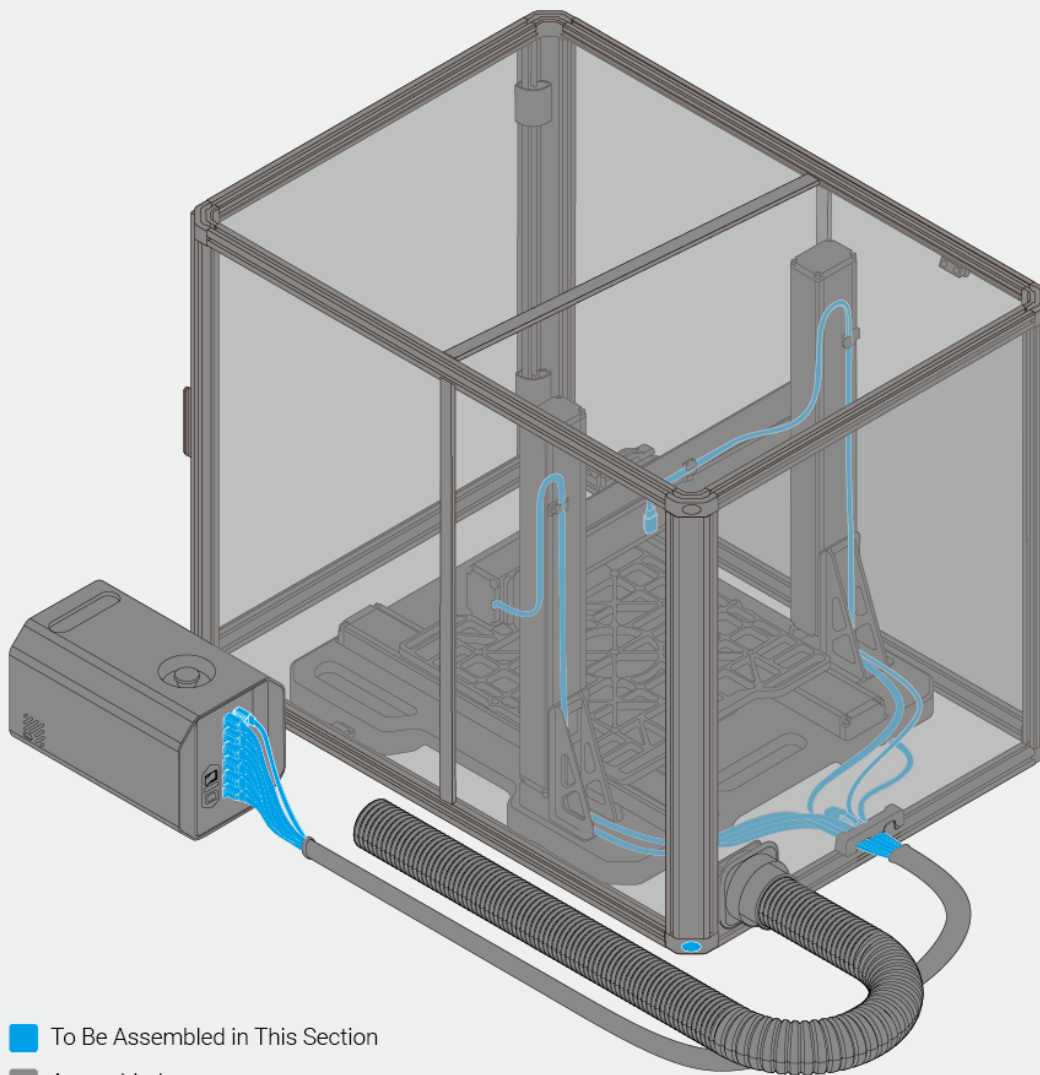

34_{/36}

Plug the toolhead cable, the Enclosure cable, the heated bed cable, and the Linear Module cables into the Integrated Controller.

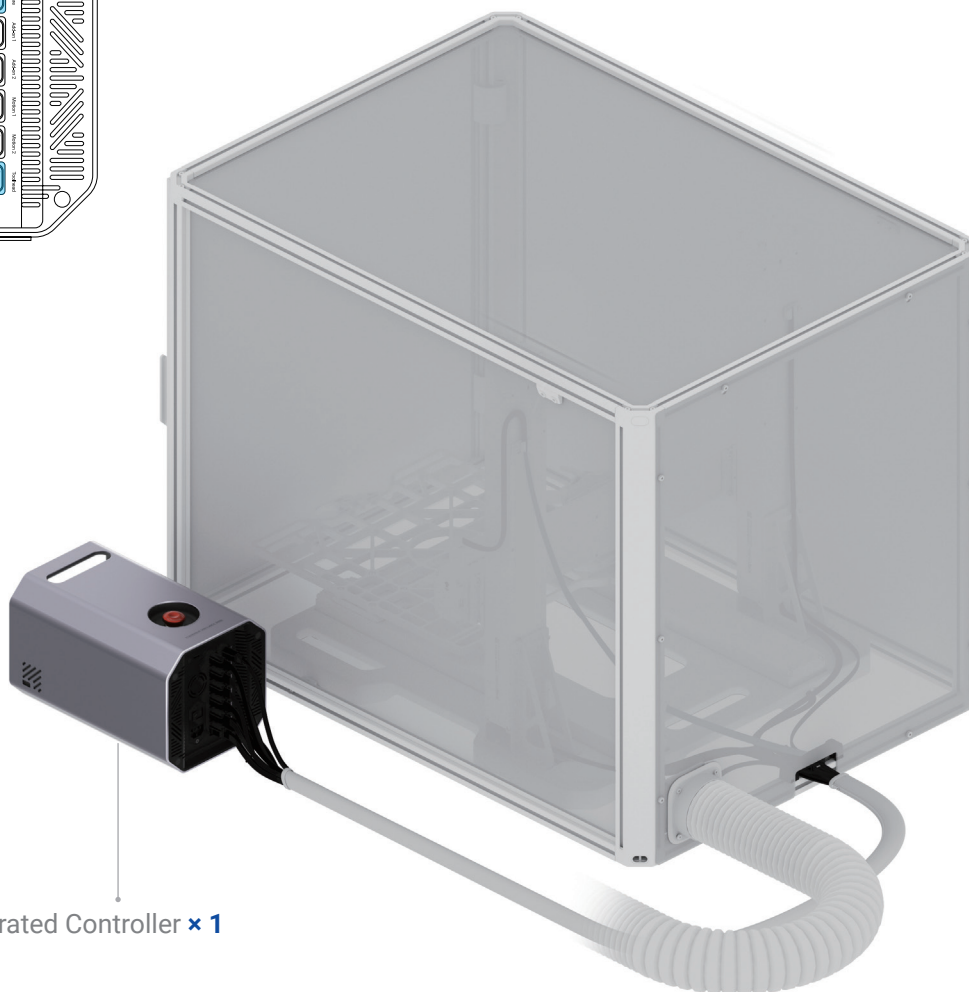
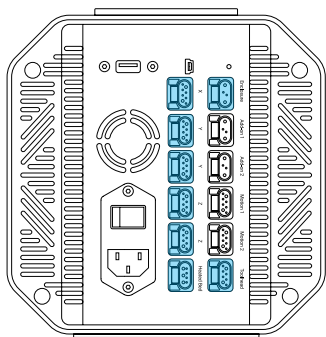

Integrated Controller x 1



Ensure that the connector is in the correct direction.



Place the Integrated Controller within easy reach so that you can press the emergency stop button on top of the controller to respond quickly to an emergency.



It is recommended to place the integrated controller on the right side of the Enclosure to make it easier for you to operate the Touchscreen when the Enclosure door is open.

35_{/36}

Insert the sealing plugs into the four bottom profile connectors.

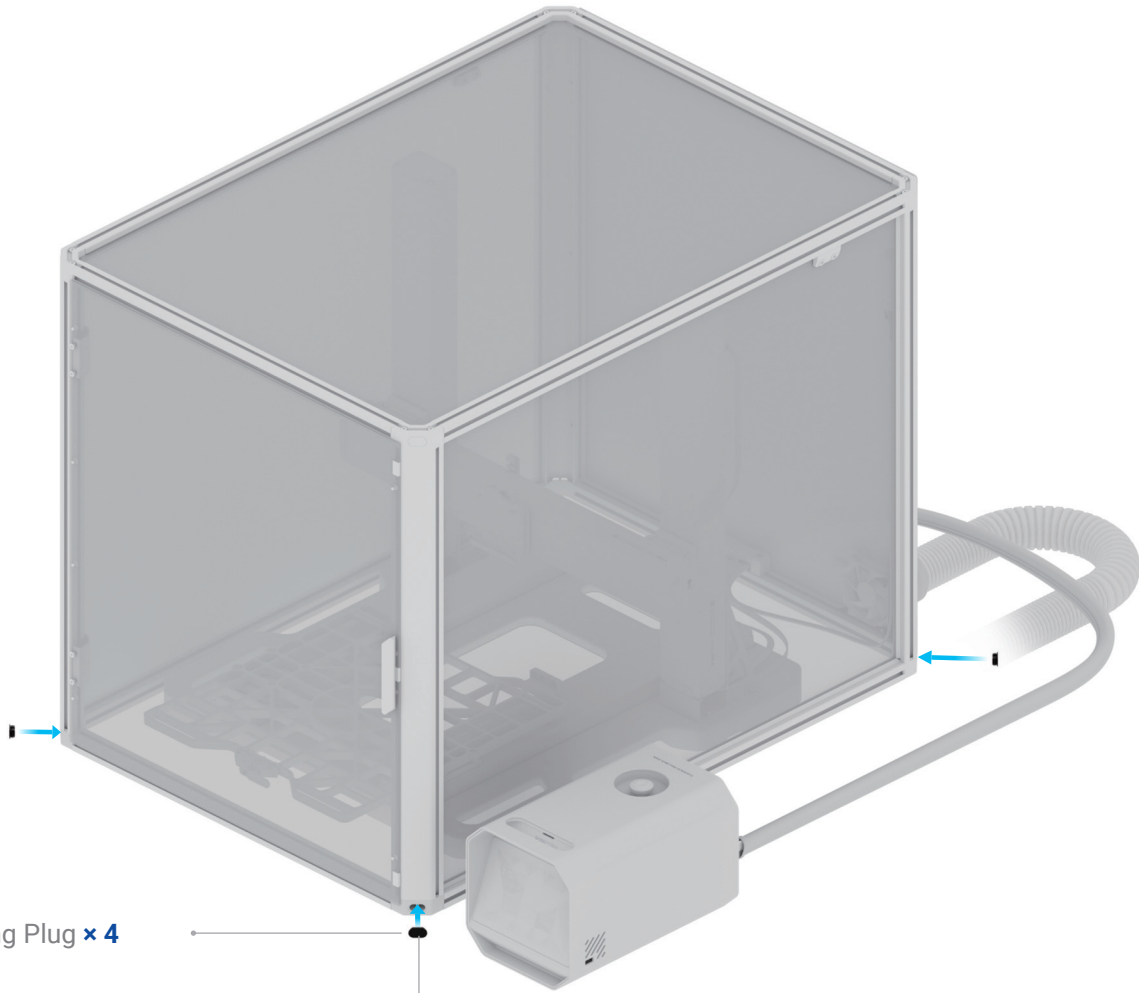

Sealing Plug x 4

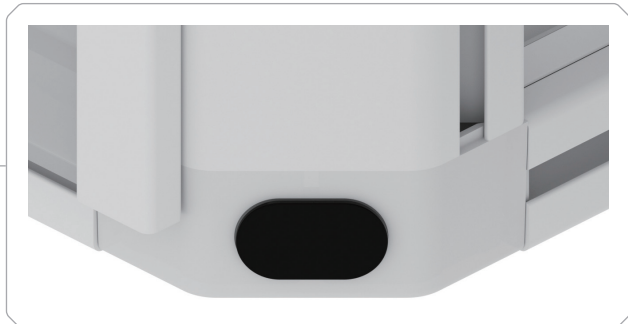

36_{/36}

Connect the upper and lower base fixtures to lock the relative position of the machine and the Enclosure.

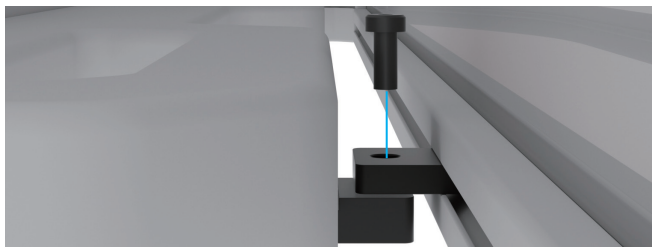
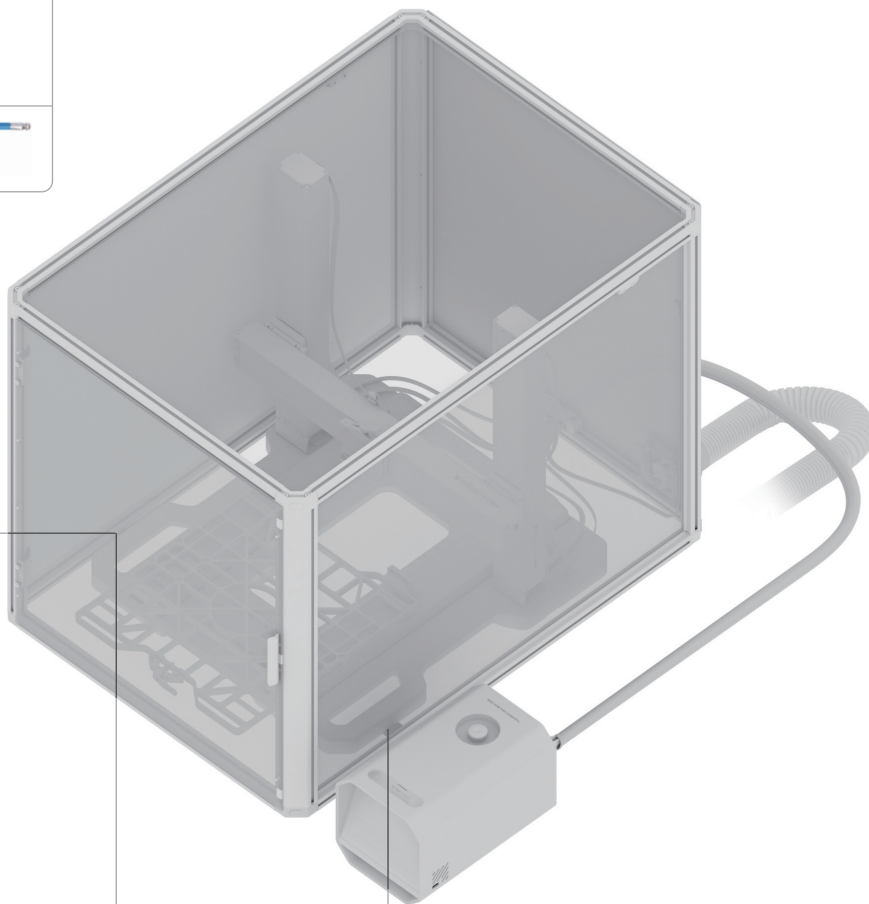

To move the Enclosure or the machine, you must first separate the machine and the Enclosure.

2.1 Enable/Disable Door Detection

The column-2 of the Enclosure features a hall switch to detect whether the door is opened or closed in real time.



You can tap **Settings** > **Enclosure** to enable or disable Door Detection during a 3D printing or CNC process. During a laser process, Door Detection is enabled by default and cannot be disabled.

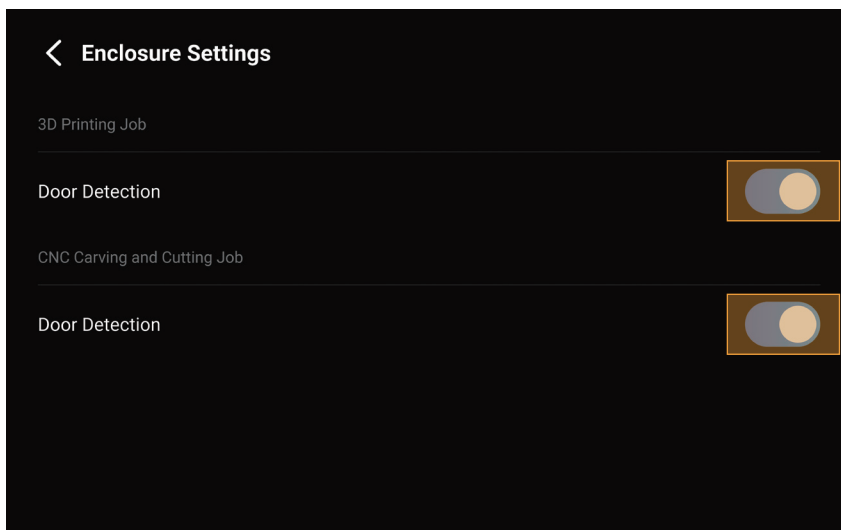

After Door Detection is enabled, the machine will stop operating or end the calibration process immediately whenever the hall switch has detected that the door is opened. To resume operations, you need to close the door first, and then tap  on the Touchscreen to continue the job or restart the calibration process.

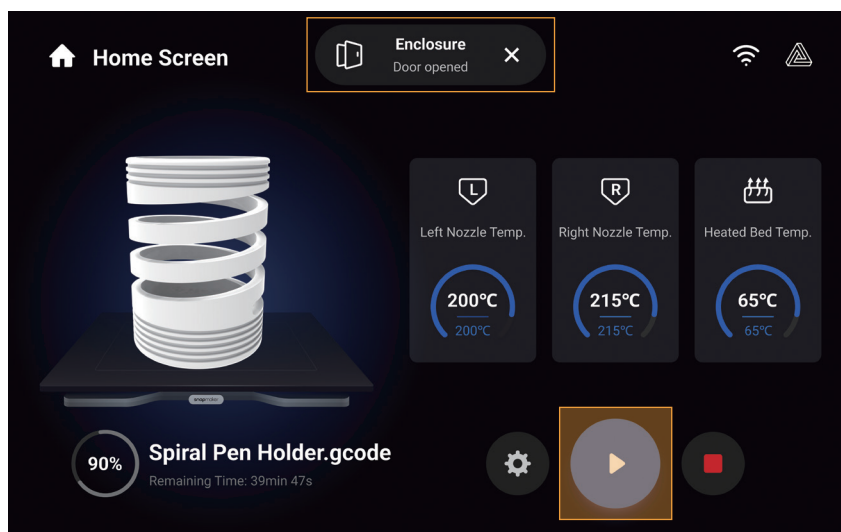
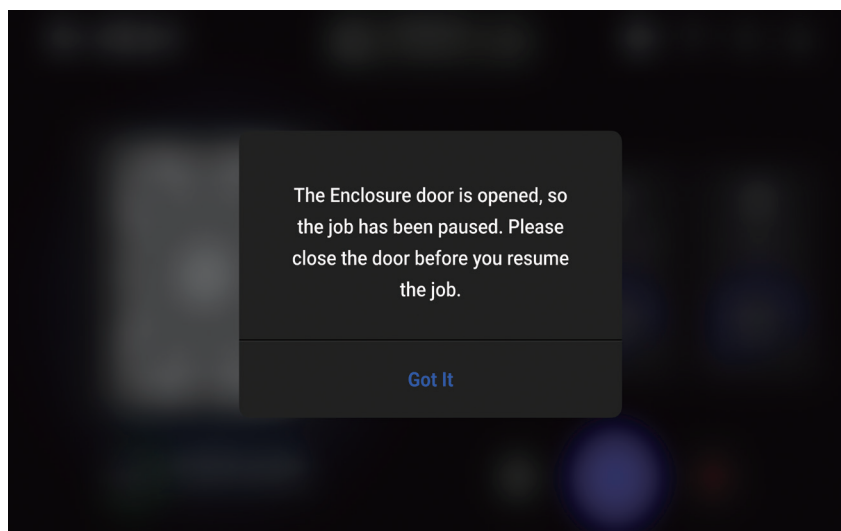

If you need to open the door frequently and do not want the ongoing 3D printing or CNC process to be paused as the door opens, you can disable Door Detection before starting a 3D printing or CNC job.





Whether Door Detection is enabled or not, you must wear the CNC safety goggles before opening the door during a CNC process.

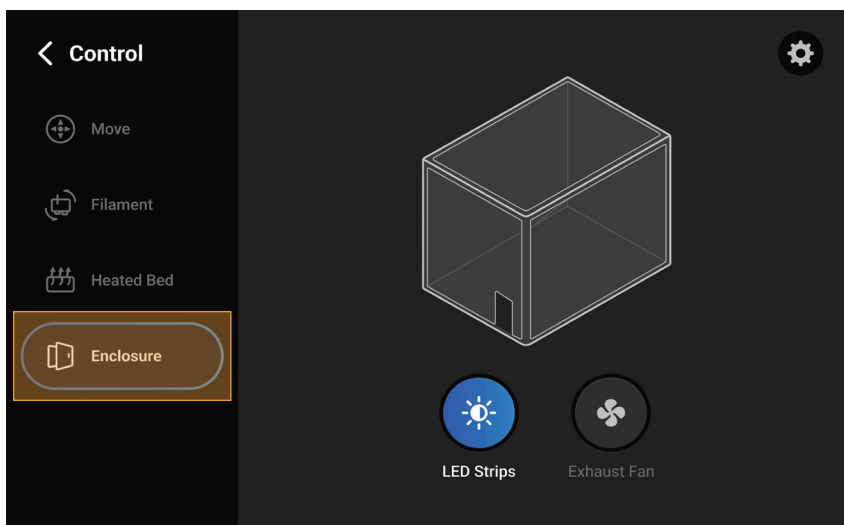

2.2 Turn On/Off LED Strips and the Exhaust Fan

You can tap **Control** > **Enclosure** to turn on or off the LED strips and the exhaust fan.



You can also tap  to adjust the settings of the LED strips and the exhaust fan during a 3D printing, laser, or CNC process.

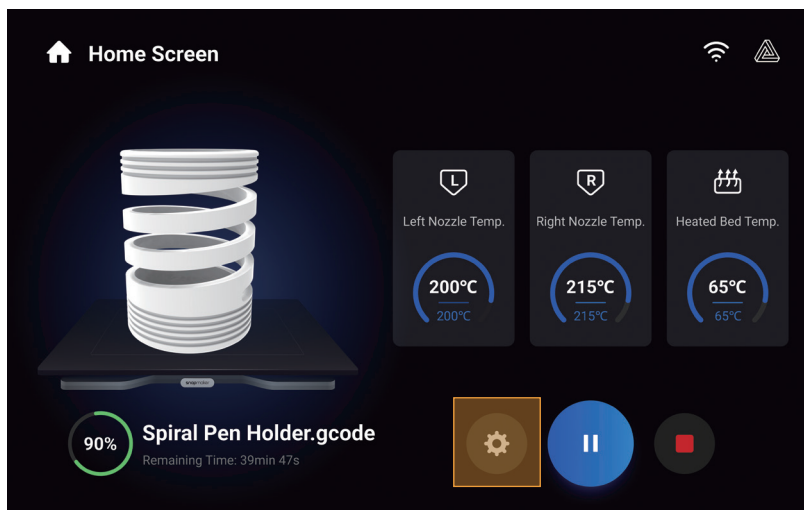

For different scenarios, we recommend turning on or off the LED strips and the exhaust fan as shown in the table:

Scenario		LED	Fan
3D Printing	PLA, Breakaway Support for PLA, TPU90, TPU95, High Flow TPU95, TPU-Foam, PVA	O	O
	ABS, PETG, ASA, HIPS, CoPA, PA12-CF, PA6-CF, PA6-GF	O	X
Laser Engraving and Cutting		O	O
CNC Carving and Cutting		O	X

*O = On X = Off



Some filaments (such as ABS) may give off odors or fumes during a 3D printing process, while turning on the exhaust fan may affect the printing temperature and therefore impair the print quality. In this case, you can turn on the exhaust fan after printing. To protect your health and prevent environmental pollution, we recommend using Snapmaker Air Purifier or other air purifying devices during such a 3D printing process.

Laser Engraver and Cutter Assembly



01 /15

Loosen the cam handle of the support platform by turning it to the left, and install the laser engraving and cutting platform onto the support platform.

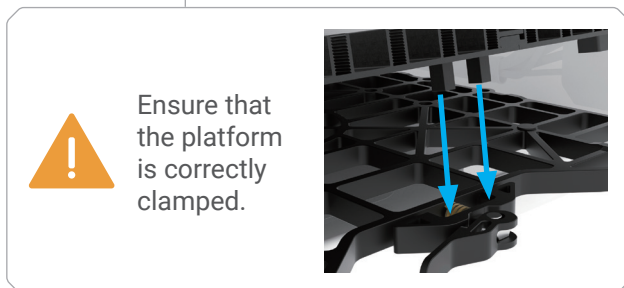
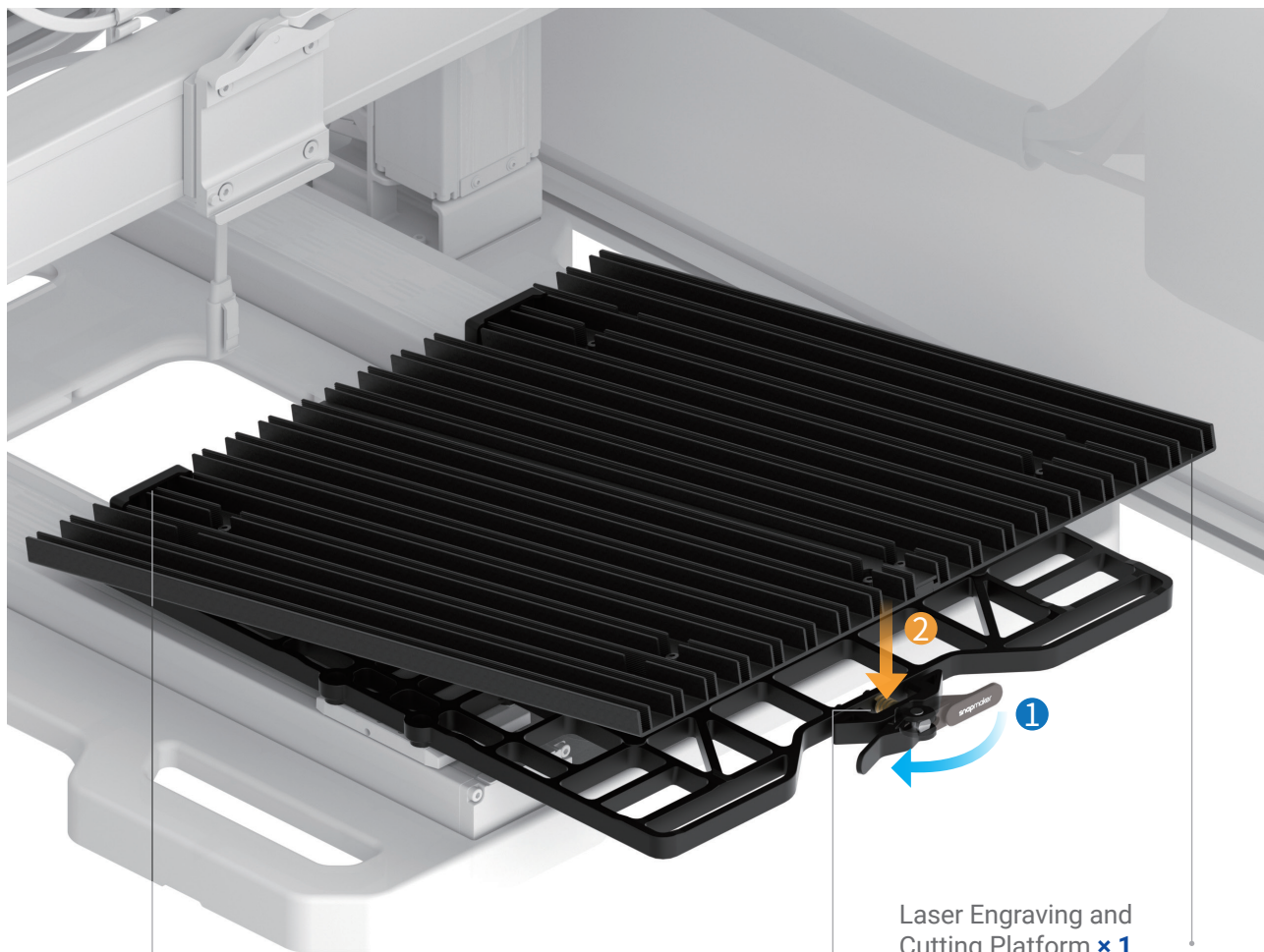

02_{/15}

Tighten the cam handle of the support platform by turning it to the right.

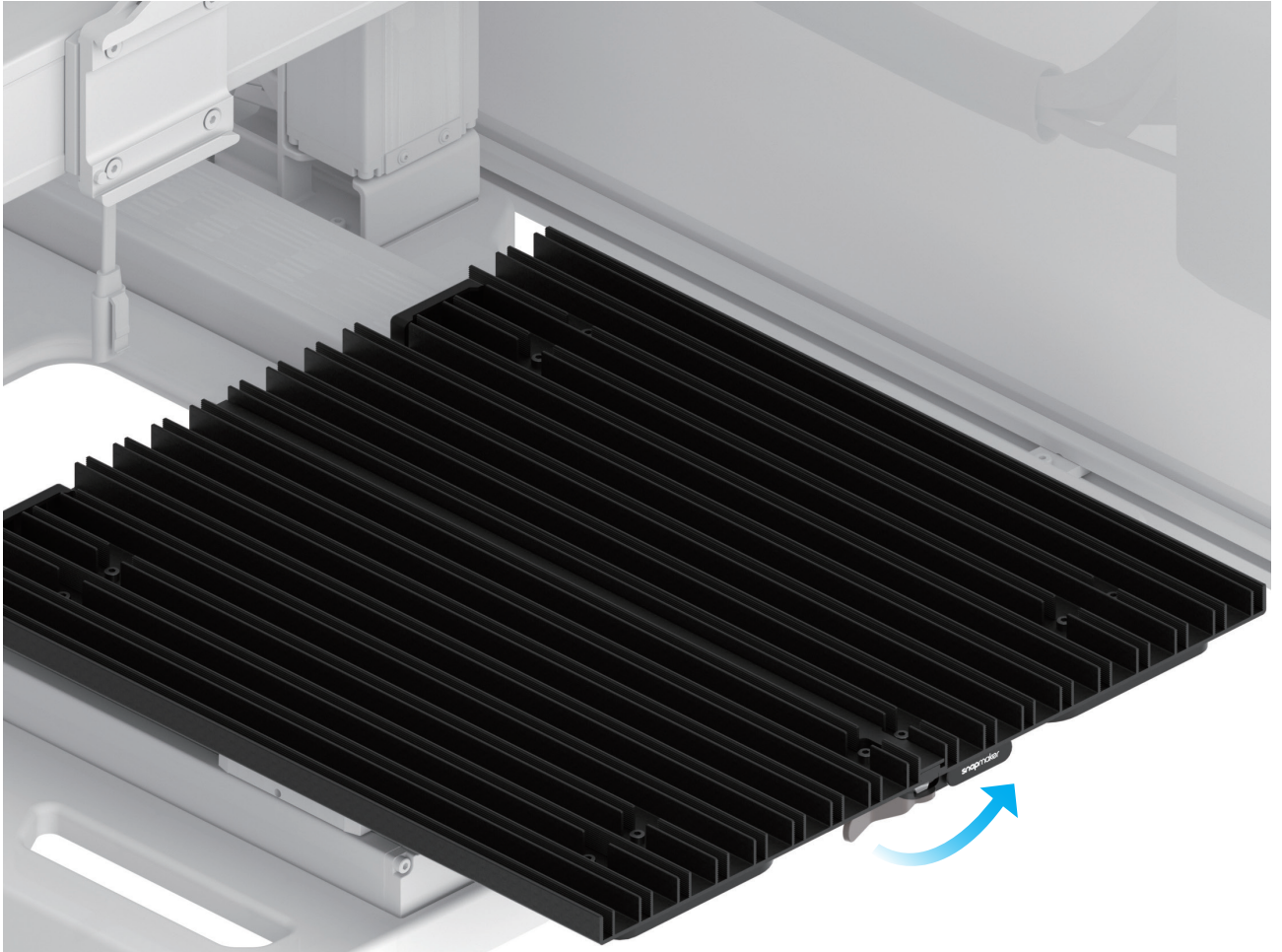

03 /15

Attach the toolhead quick-swap plate to the 40W Laser Module using the H2.5 hex key and the M4 × 12 screws.

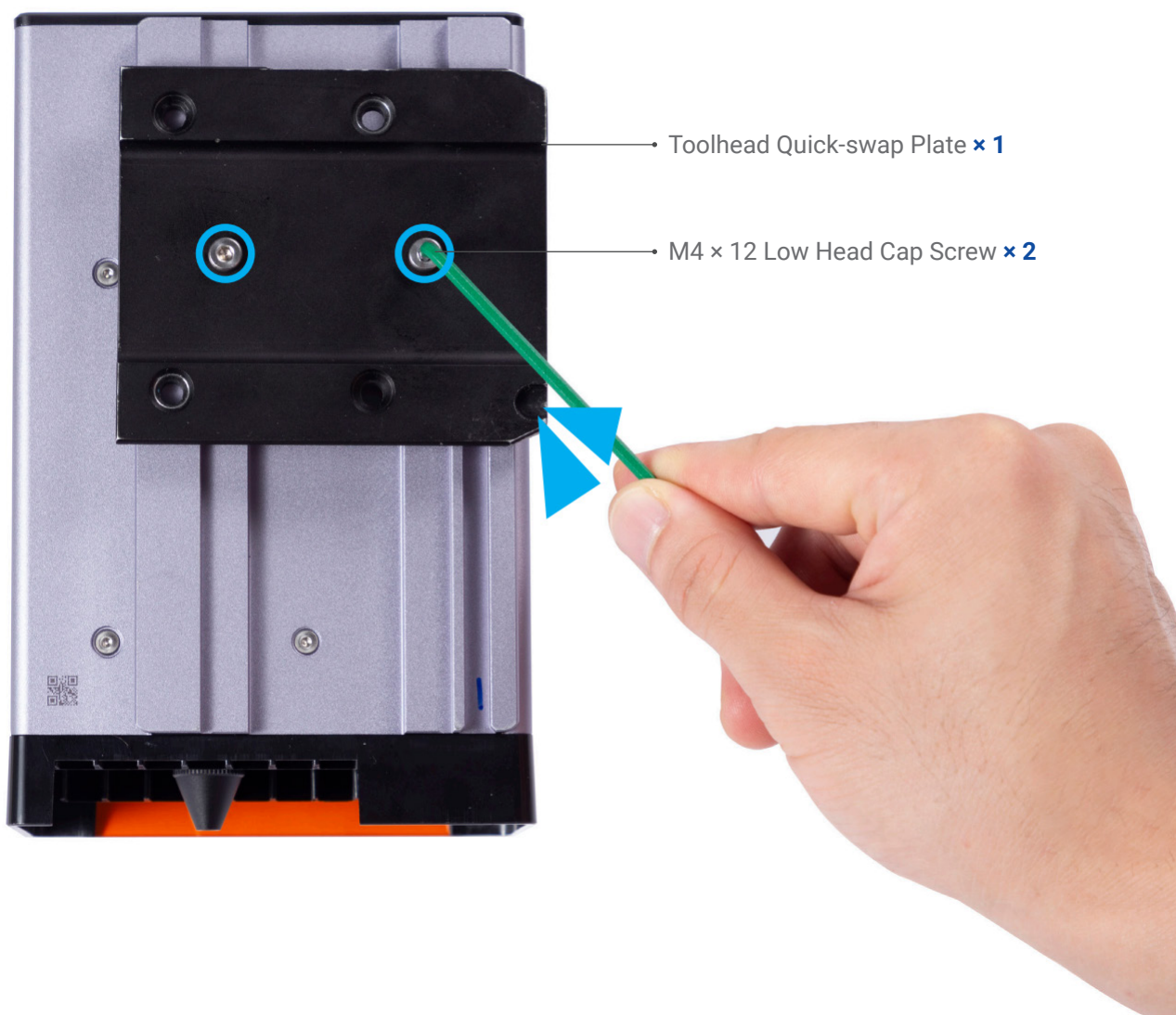

Skip this step if the toolhead quick-swap plate has been pre-assembled.

04_{/15}

Loosen the cam handle of the toolhead bracket by turning it to the left, and then slide the Laser Module into the bracket.

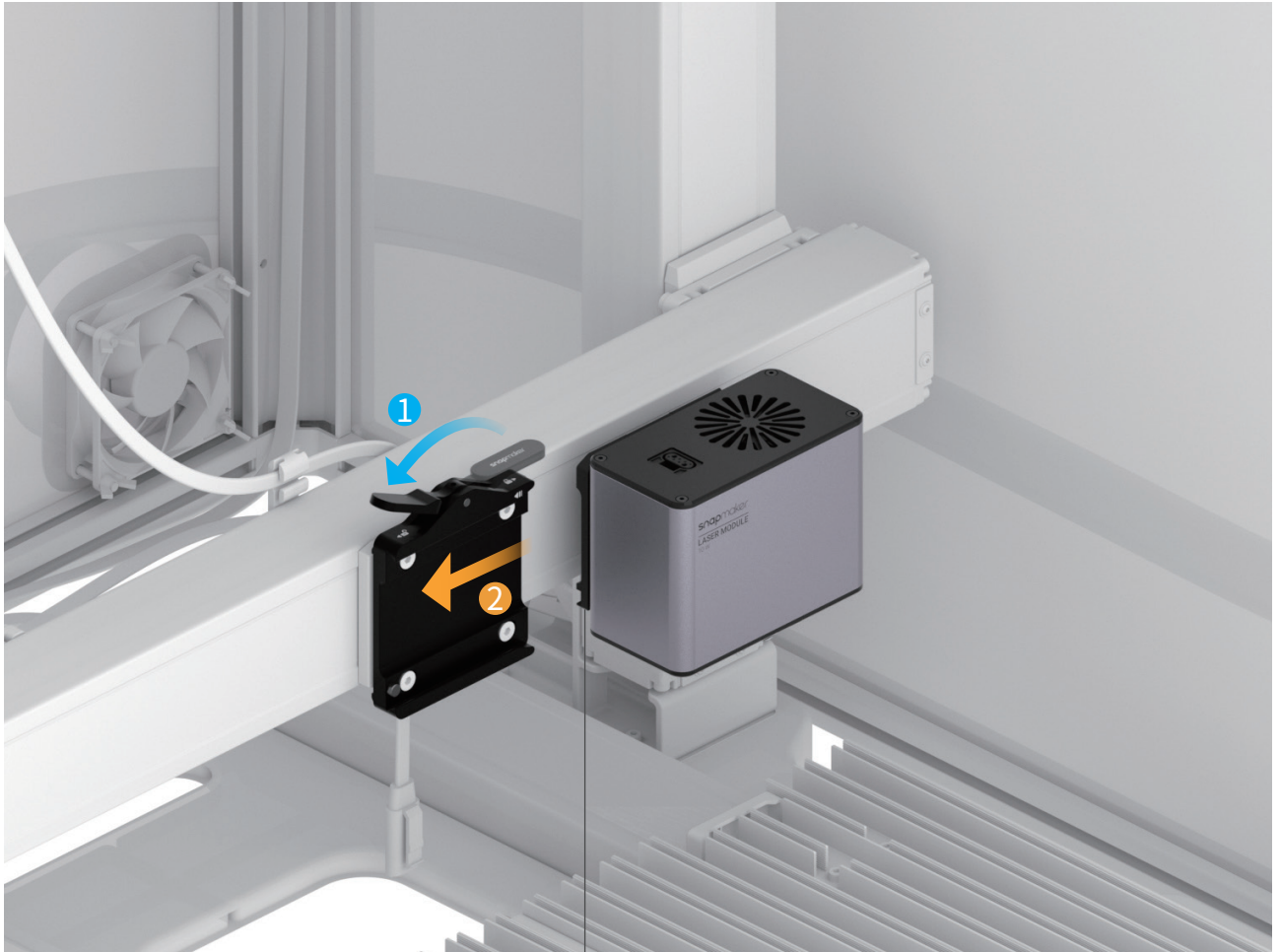

This guide takes 10W Laser Module as an illustration, all steps demonstrated apply to 40W Laser Module.



Make sure to fully slide the toolhead into the bracket.



05_{/15}

Tighten the cam handle of the toolhead bracket by turning it to the right.

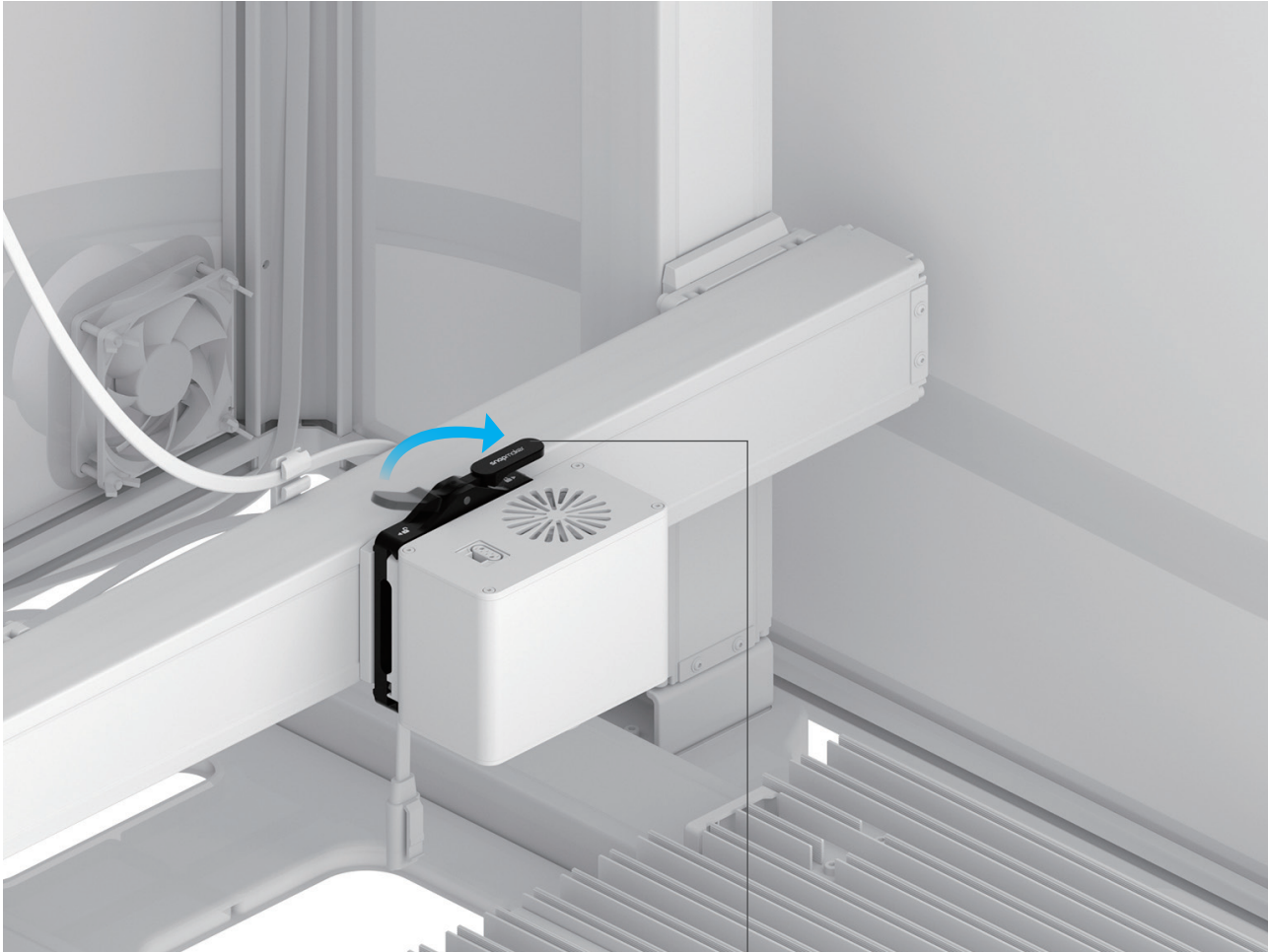

Make sure to fully tighten the cam handle.

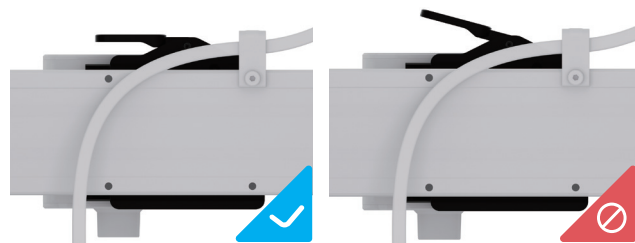

06 /15

Plug the toolhead cable into the Laser Module.



Ensure that the connector is in the correct direction.

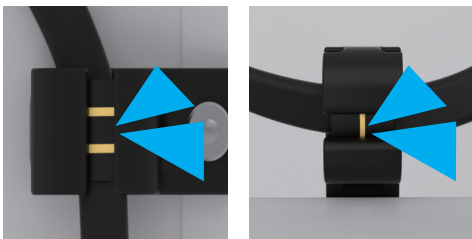
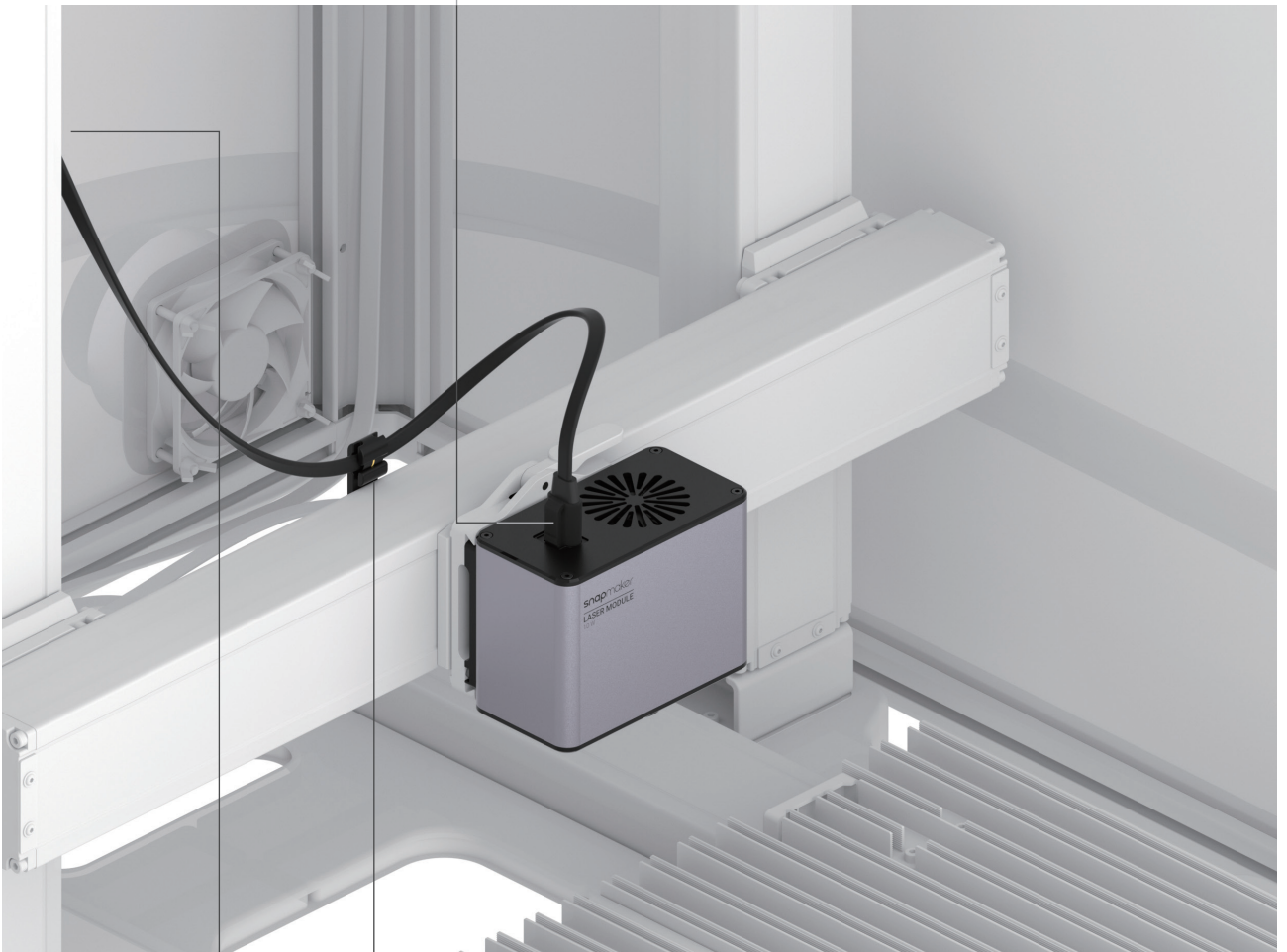
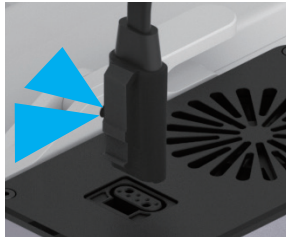

07 /15

Plug the AC power cable into the Integrated Controller and the electric outlet.



Before plugging, ensure that the power switch is OFF.



Do NOT plug or unplug any cables when the machine is powered on.

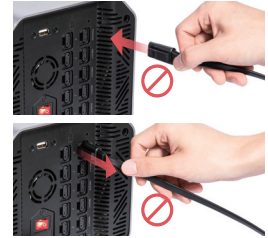

AC Power Cable x 1



08 /15

Attach the M5 air tube connector to the toolhead.



09 /15

Insert the air tube into the tube connector.

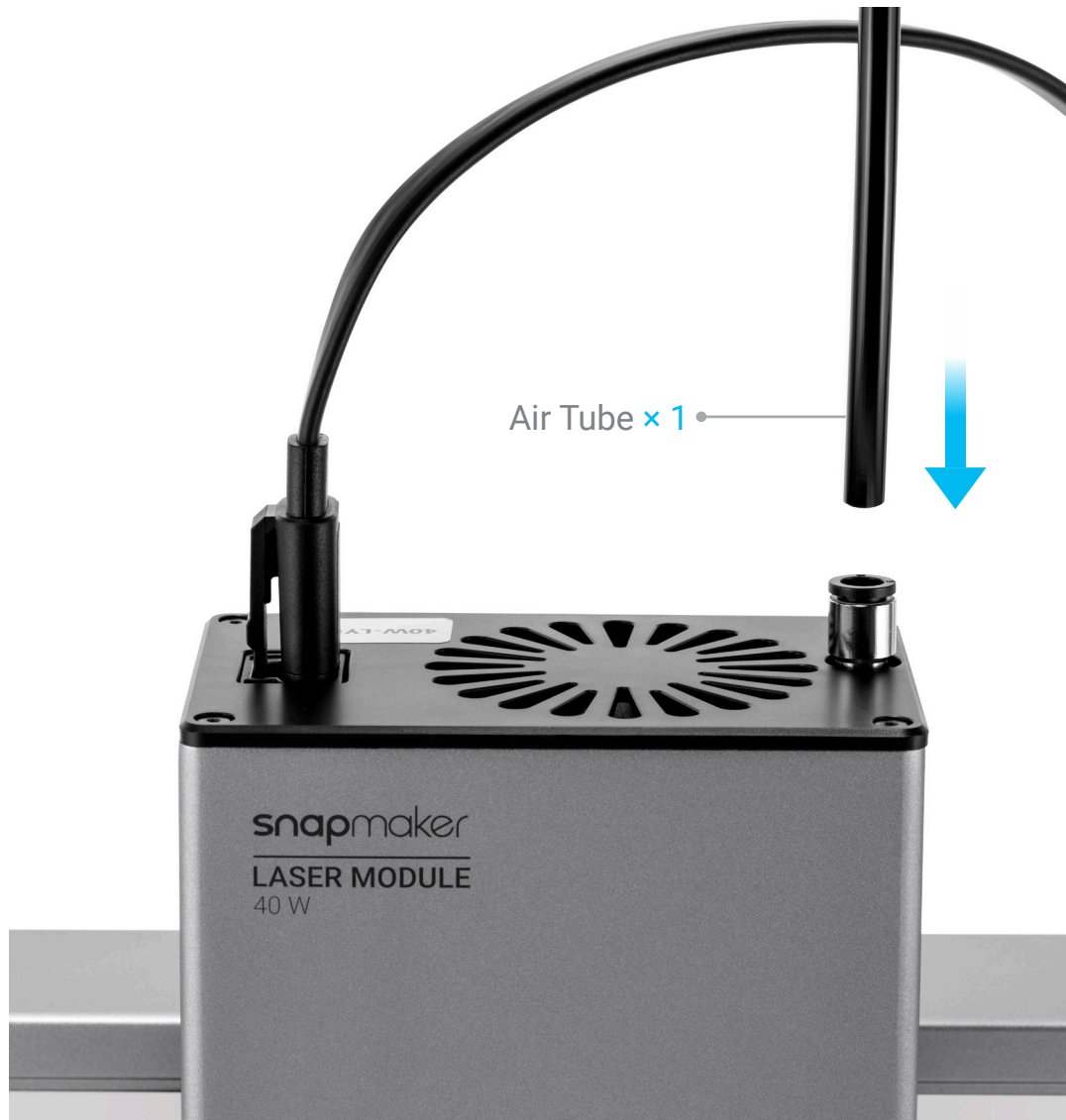

1



2



To pull out the air tube, firmly press the round clamp of the air tube connector while pulling.

10_{/15} | Cut the cable ties into four, and use them to collect and fix the toolhead cable and the air tube.



11 /15

Thread the air tube through the leftmost hole of the cable pass-through fixture to the outside of the Enclosure.



12_{/15}

Use the cable collector to organize the air tube together with other cables.

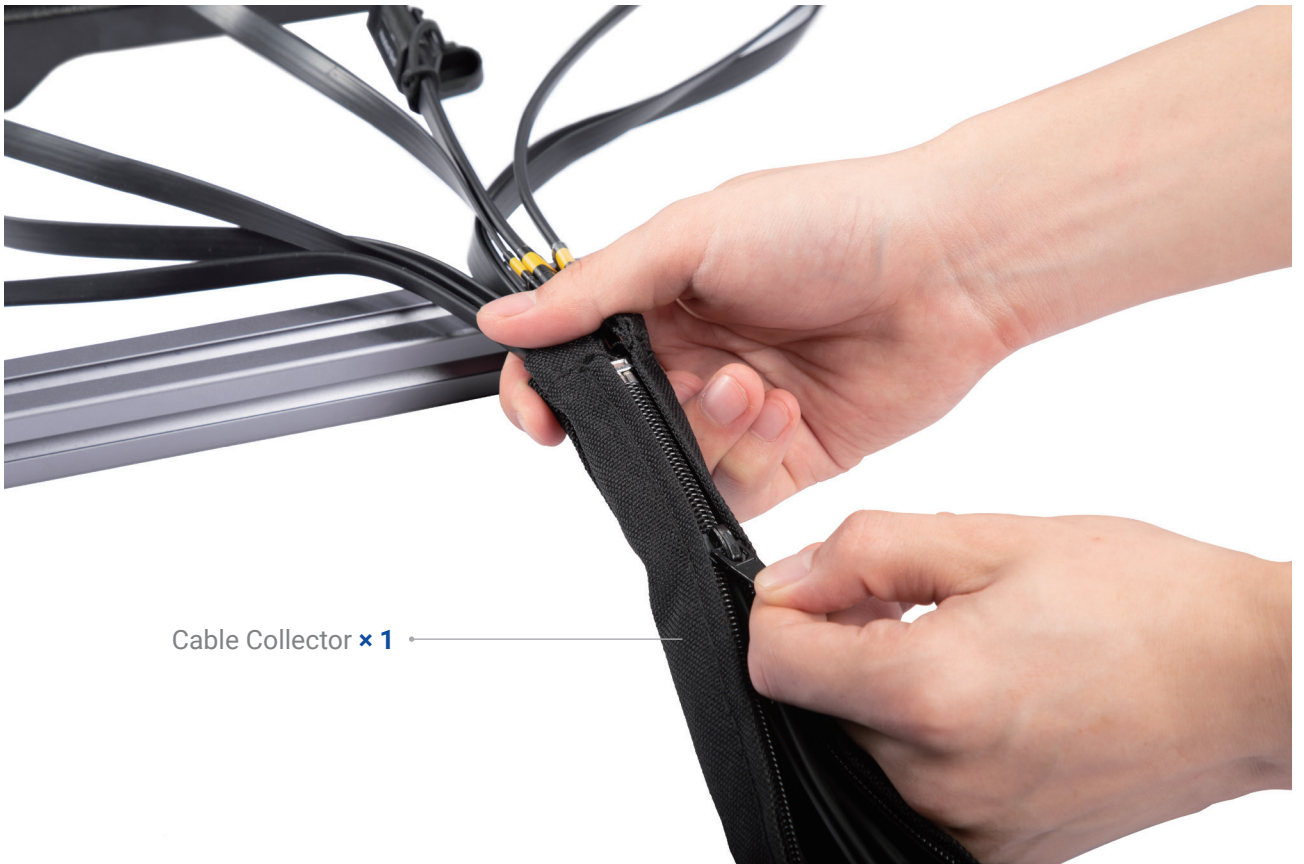

Cable Collector x 1

13_{/15}

Attach the M8 air tube connector to the air assist pump.

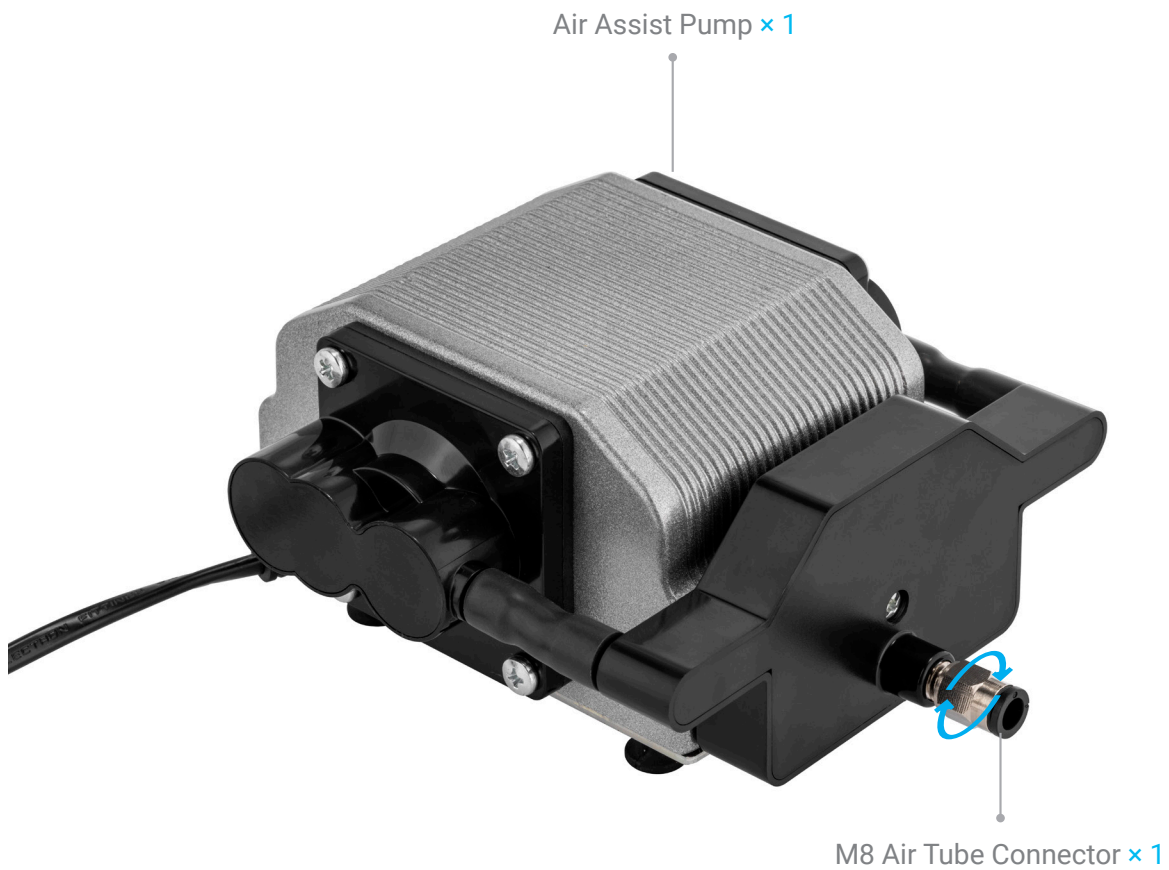

14_{/15}

Insert the other end of the air tube into the M8 air tube connector.



To pull out the air tube, firmly press the round clamp of the air tube connector while pulling.

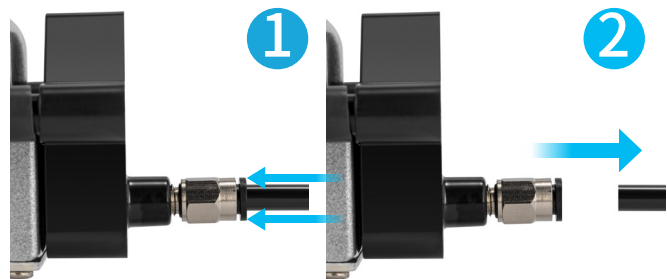

15_{/15}

Insert the power cable of the air assist pump into the **Heated Bed** port of the Integrated Controller.

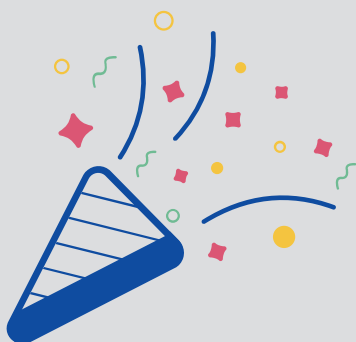
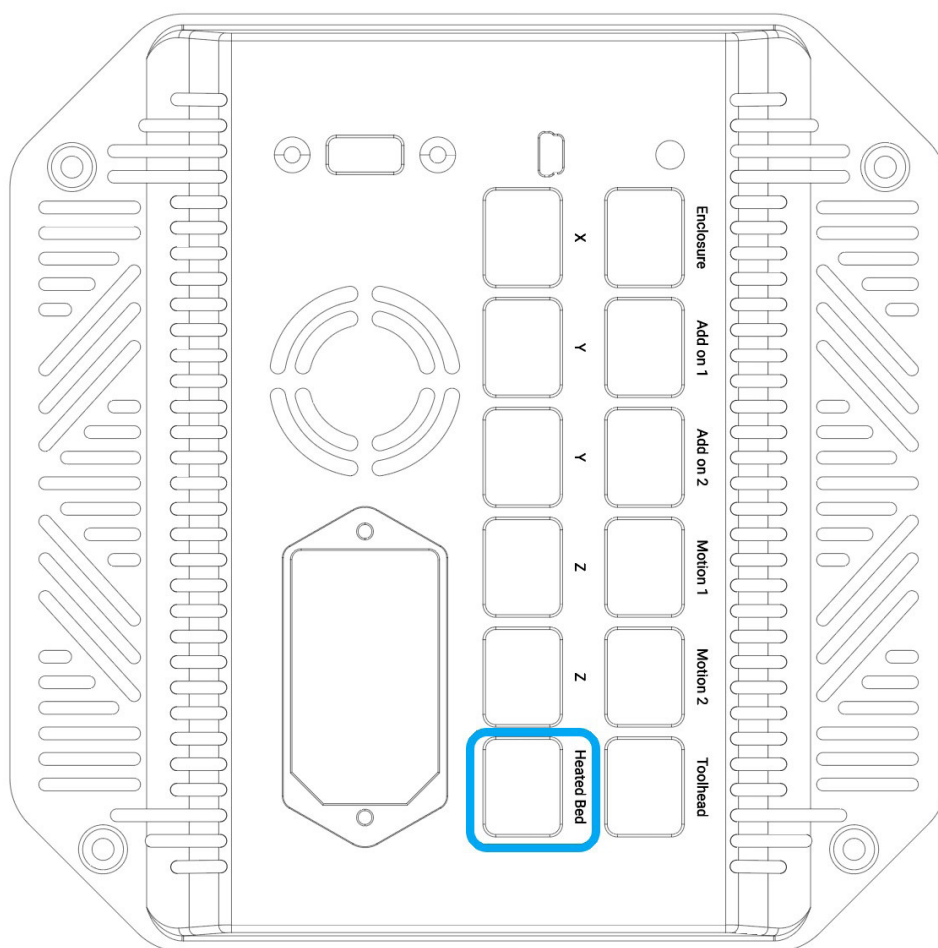

Congrats! You have completed the assembly.

Tear off the base plate sticker. To bring your first job into the world, refer to our User Manual in Snapmaker Wiki (<https://wiki.snapmaker.com>).

MAKE SOMETHING WONDERFUL

CNC Carver and Cutter Assembly



01 /06

Loosen the cam handle of the support platform by turning it to the left, and install the CNC carving and cutting platform onto the support platform.

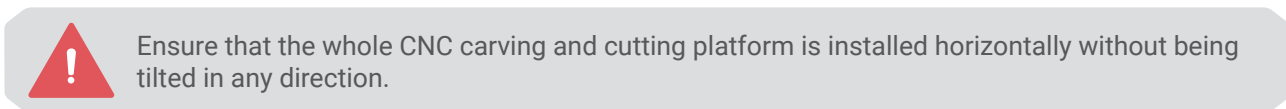
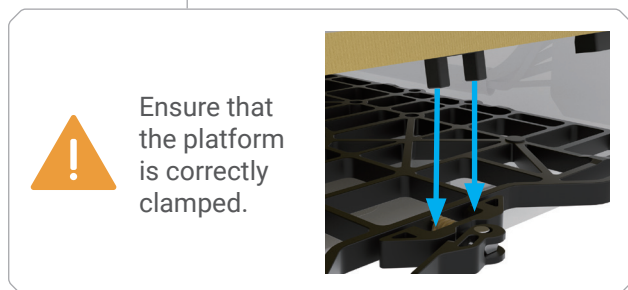
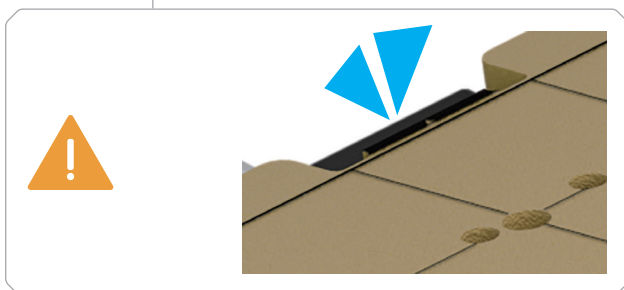
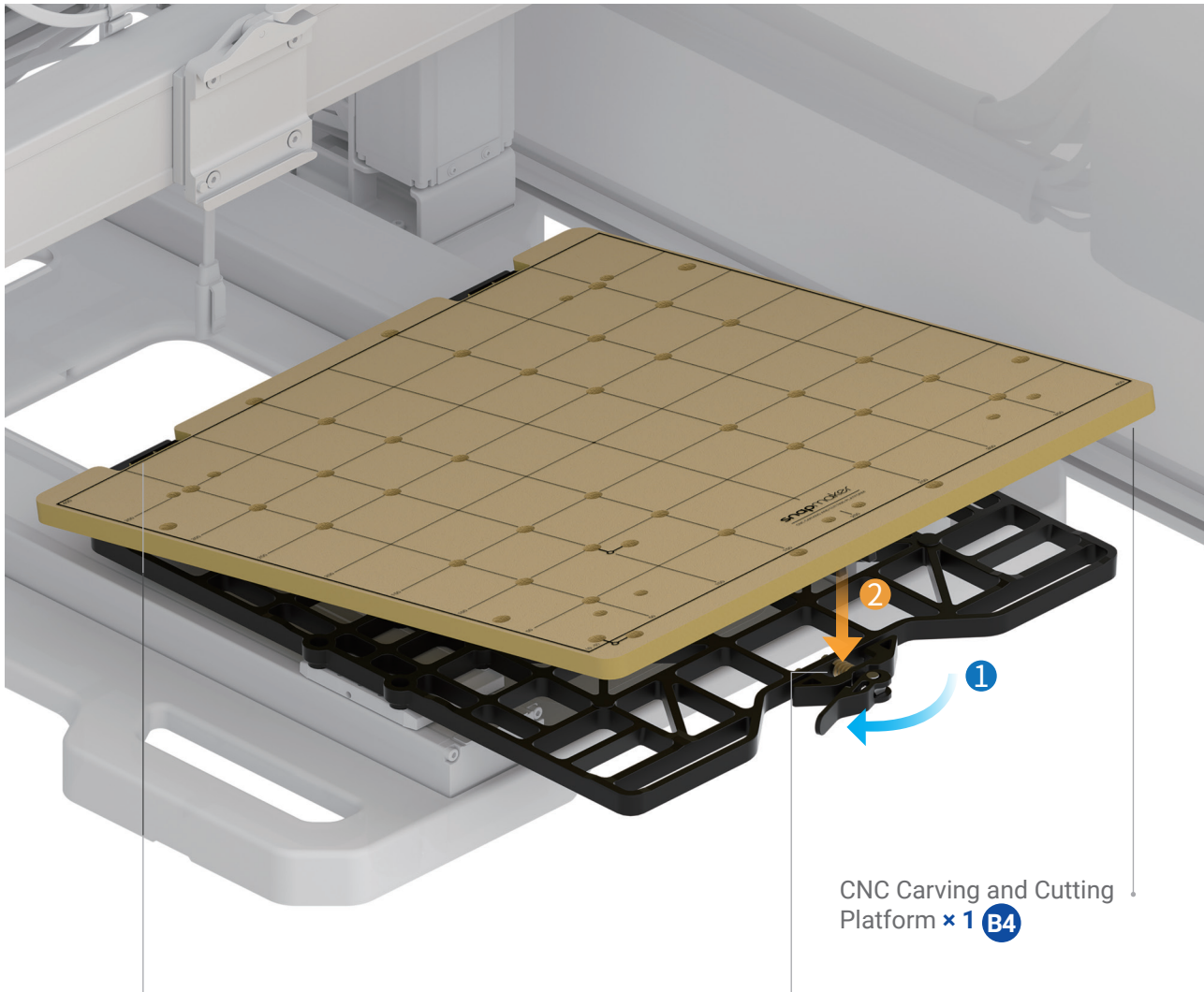

02_{/06}

Tighten the cam handle of the support platform by turning it to the right.

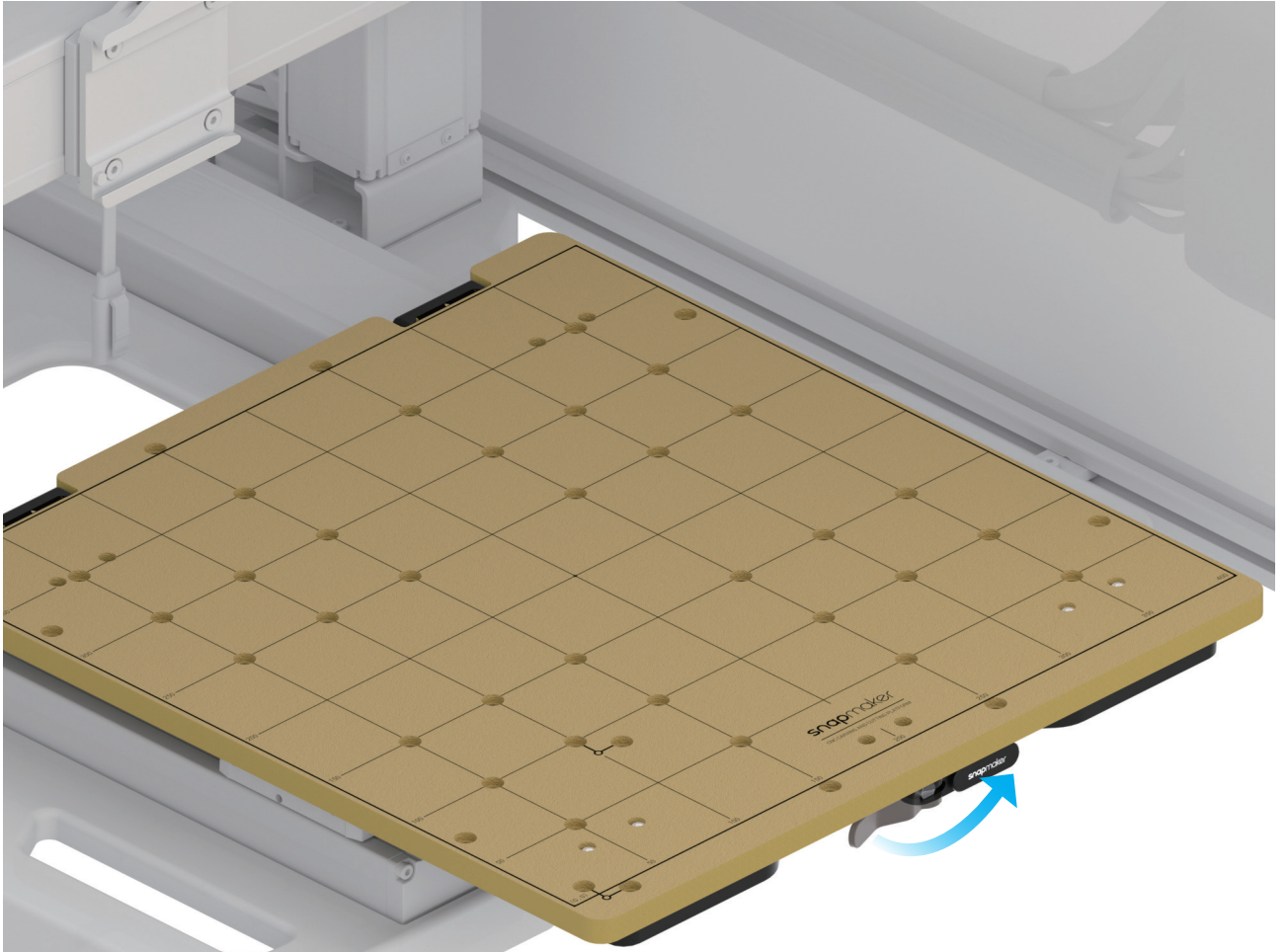

03_{/06}

Loosen the cam handle of the toolhead bracket by turning it to the left, and slide the 200W CNC Module into the bracket.



Make sure to fully slide the toolhead into the bracket.



04_{/06}

Tighten the cam handle of the toolhead bracket by turning it to the right.

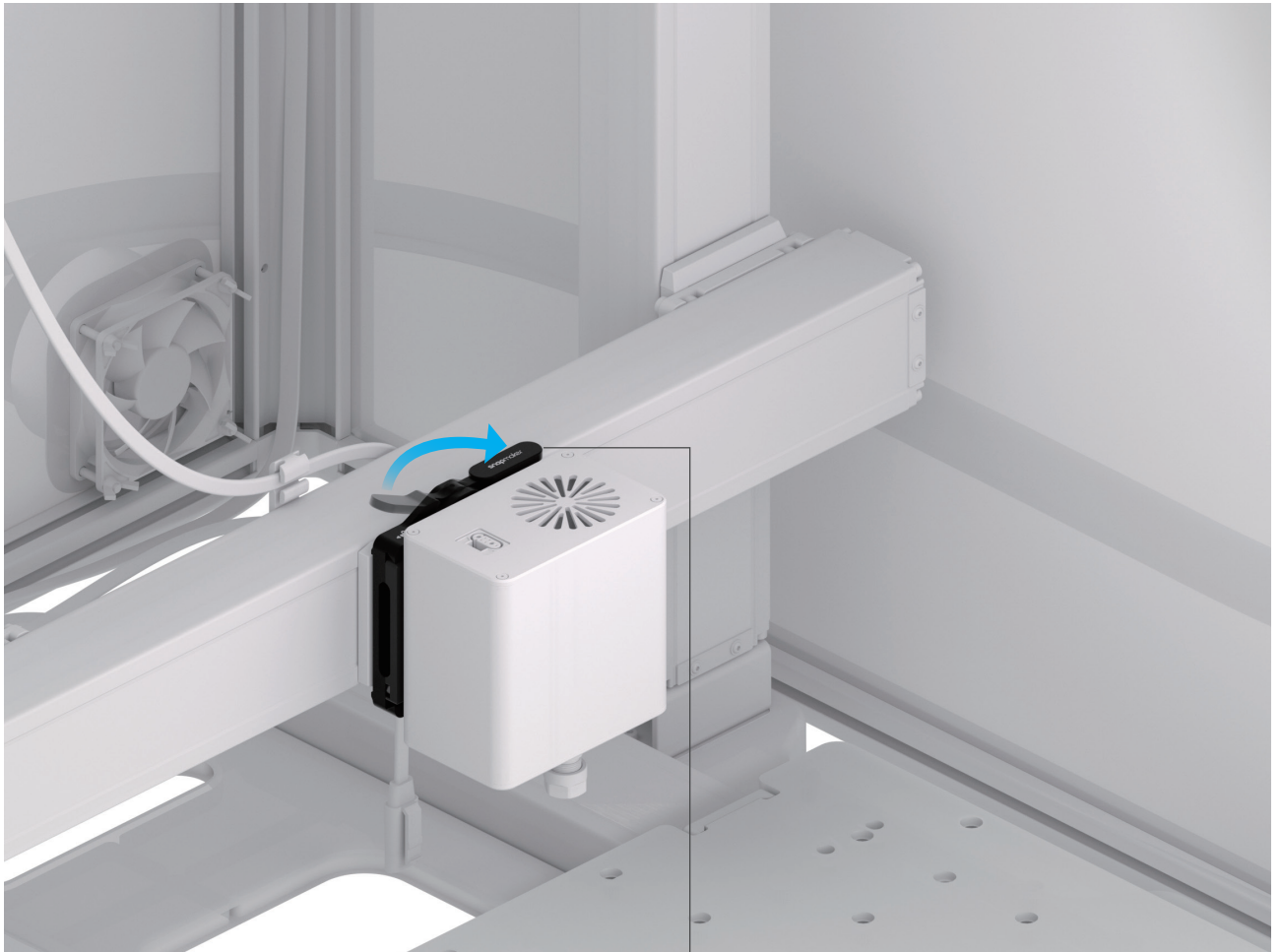

Make sure to fully tighten the cam handle.

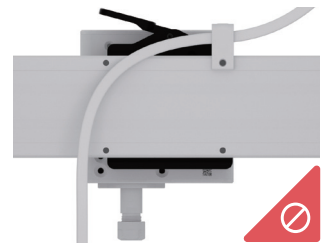
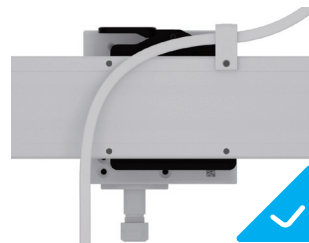

05_{/06}

Plug the toolhead cable into the 200W CNC Module.



Ensure that the connector is in the correct direction.

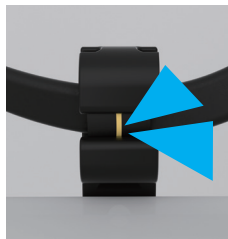
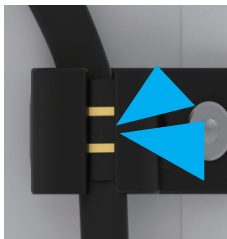
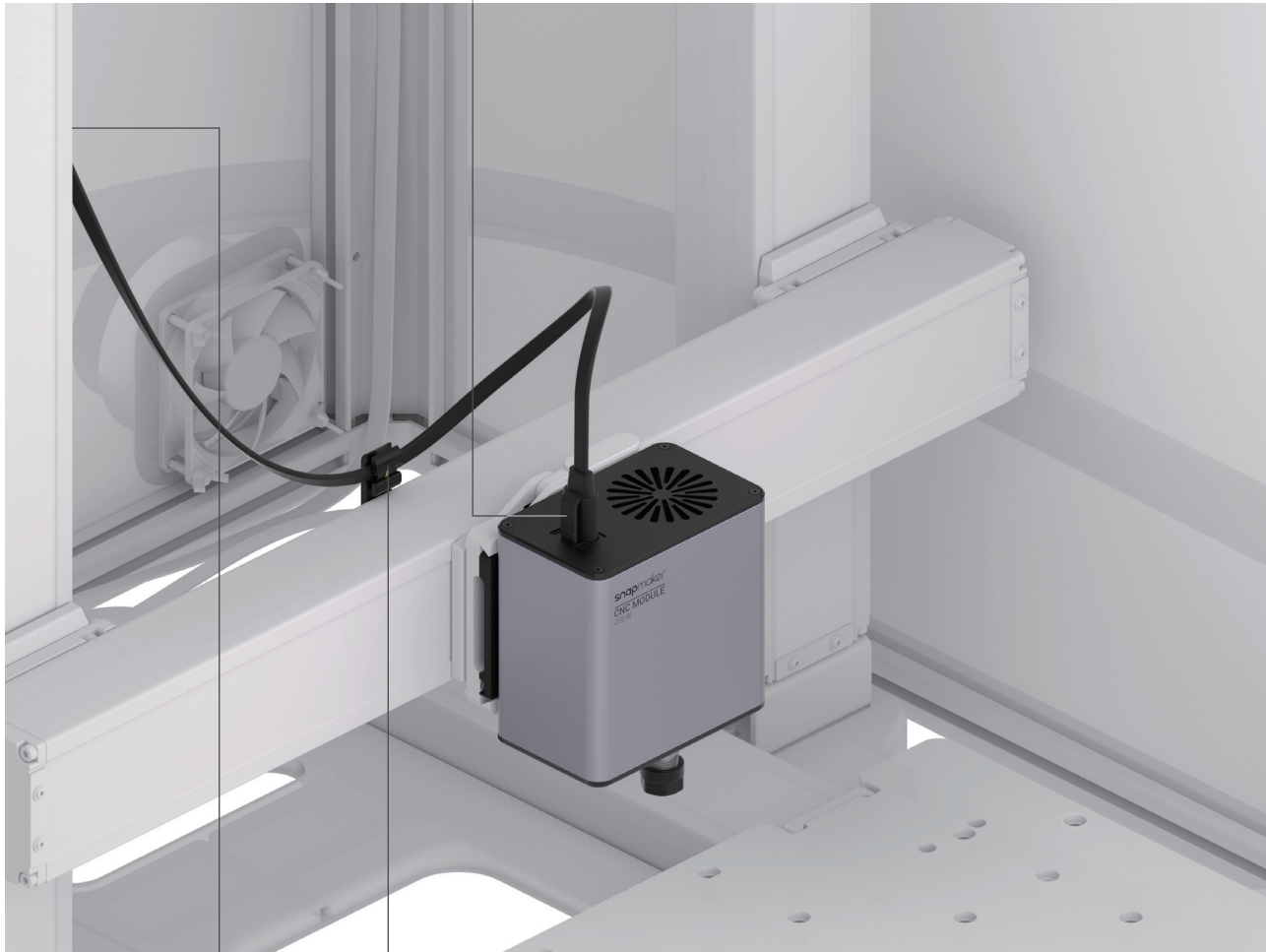

06_{/06}

Plug the AC power cable into the Integrated Controller and the electric outlet.



Before plugging, ensure that the power switch is OFF.



Do NOT plug or unplug any cables when the machine is powered on.

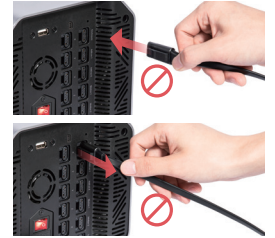

AC Power Cable x 1



Congrats! You have completed the assembly.

Tear off the base plate sticker. To bring your first job into the world, refer to our User Manual in Snapmaker Wiki (<https://wiki.snapmaker.com>).

Resources

You can learn more about the usage, maintenance, and troubleshooting of your printer in Snapmaker Wiki:
<https://wiki.snapmaker.com>

We are here for you whenever you need support:
<https://support.snapmaker.com>

For any sales inquiries:
sales@snapmaker.com

For product purchases:
<https://shop.snapmaker.com>

Share anything you want with other Snapmaker users in our forum:
<https://forum.snapmaker.com>



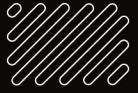

SCHAFFEN SIE
ETWAS
WUNDERBARES

$$\int_0^{\text{Wonderful}} \text{make}(x)dx = \text{snapmaker}$$

"We are all in the gutter, but some of us are looking at the stars."
— Oscar Wilde