

DESCRIPTION

The RQCBOX allows the direct connection and communication of a Gimatic's RIFD reader (either RAQC or RAQCN) with a computer for configuration and testing purposes.

Main characteristics:

- RS232 communication eventually using standard USB to RS232 converters from the market;
- automatic recognition of PNP and NPN reader types (RAQC and RAQCN, respectively);
- 8 embedded LED for a direct visualization of the TOOL ID memorized into the TAG;
- push button to simulate the acknowledgment signal normally provided by a sensor box for testing cycles counter functionality of the RIFD system.



SPECIFICATIONS

	RQCBOX
Frame	PA12
Allowed temperature range	-20÷65°C
Dimensions box	45 mm x 42 mm x 15 mm
Weight	30 g
Electrical connection	DB 15 pins female (HD)
Environmental degree	IP40
Power supply	24 Vdc ± 10%, 0.15 Arms
Communication interface	RS232

ELECTRIC CONNECTIONS

Electric connection to the reader unit (RAQC or RAQCN) is available by means of a 15 pins (high density) DB female connector according to the following schema.

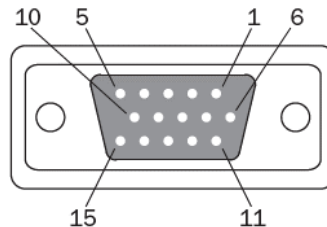

Pin #	Pin Name	Description
Pin 1	DO_1	Digital output #1 (bit 1 of the binary representation of tool ID) - LSb
Pin 2	DO_2	Digital output #2 (bit 2 of the binary representation of tool ID)
Pin 3	RS_TX	RS232 Tx signal (only for TAG configuration – optional use)
Pin 4	GND	Power Supply GND
Pin 5	RS_RX	RS232 Rx signal (only for TAG configuration – optional use)
Pin 6	24 Vdc	Power Supply 24 Vdc
Pin 7	DO_Count	Digital output (maintenance alarm) (when set, tool executed the predefined number of working cycles)
Pin 8	DO_3	Digital output #3 (bit 3 of the binary representation of tool ID)
Pin 9	DO_Fault	Digital output (fault condition)
Pin 10	DO_4	Digital output #4 (bit 4 of the binary representation of tool ID)
Pin 11	DO_5	Digital output #5 (bit 5 of the binary representation of tool ID)
Pin 12	DO_6	Digital output #6 (bit 6 of the binary representation of tool ID)
Pin 13	DO_7	Digital output #7 (bit 7 of the binary representation of tool ID)
Pin 14	DO_8	Digital output #8 (bit 8 of the binary representation of tool ID) - MSb
Pin 15	DI_Count	Digital input (cycle completed triggering signal) (the number of executed cycles is increased by one per any rising edge of this signal)

Electric connection to the readers CRAQC/CRAQCN, RRAQC/RRAQCN is available by using an adaptor cable between the RQCBOX and the reader.

Connection pinout

RFID DEVICE	COLORS ADAPTOR CABLE	PIN NAME
YELLOW (CABLE 4)	ORANGE	DO_1
PINK (CABLE 4)	YELLOW	DO_2
GREEN (CABLE 3)	DEEP GREEN	RS_TX
RED + YELLOW (CABLE 3)	BLUE	GND
PINK (CABLE 3)	LIGHT GREEN	RS_RX
GRAY (CABLE 3)	BROWN	24 Vdc
BROWN (CABLE 3)	BROWNfWHITE	DO_Count
GREEN (CABLE 4)	RED	D03
WHITE (CABLE 3)	REDfWHITE	DO_Fault
BLUE (CABLE 4)	PINK	DO_4
WHITE (CABLE 4)	VIOLET	DO_5
BROWN (CABLE 4)	GRAY	DO_6
RED (CABLE 4)	WHITE	DO_7
GRAY (CABLE 4)	BLACK	DO8
BLUE (CABLE 3)	BLACKfWHITE	DI_COUNT

Adaptor cable connection card



PC connection with different readers

- RAQC/RAQCN connection

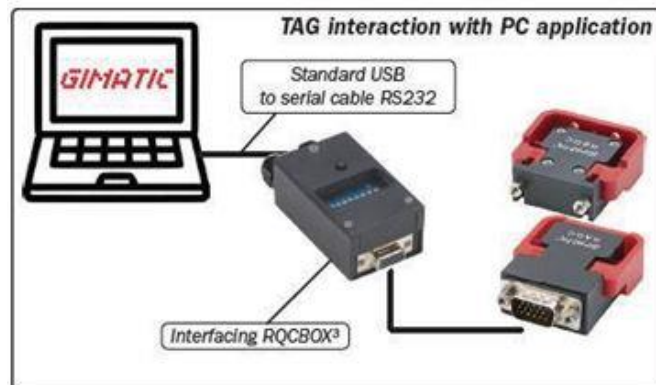

- CRAQC/CRAQCN connection

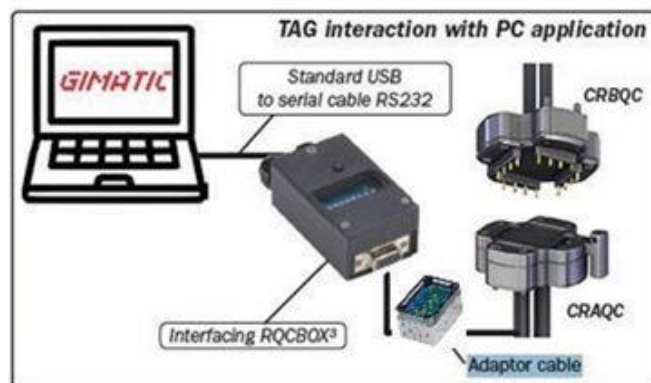

- RRAQC/RRAQCN connection

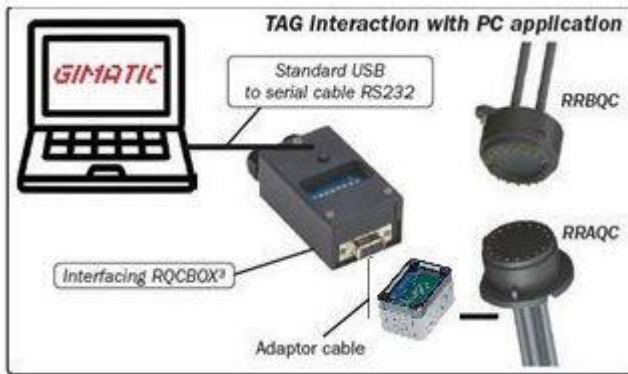

RQCBOX Setup

The RQCBOX recognize automatically the PNP/NPN configuration for the reading operations. For writing operations as: cycle counter, a manual setup is required.

The setup is described bellow:

- Unscrew the screws on the 2 sides and on the cover as shown in the attached pictures

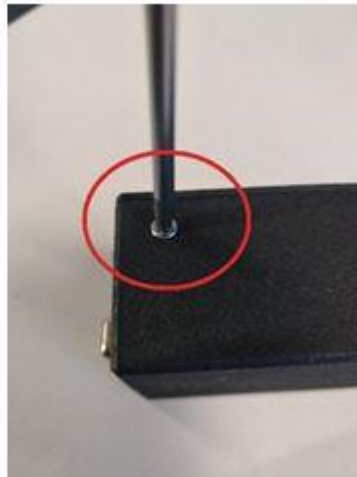

- Set the desired configuration like in the attached pictures

PNP Configuration

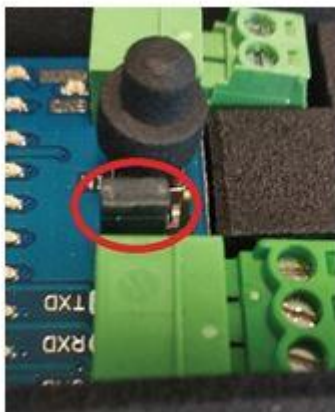

NPN Configuration

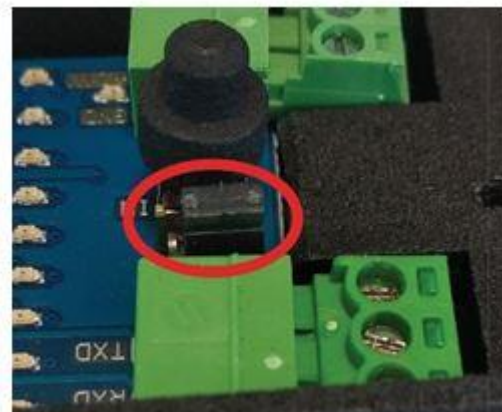

- Place the cover and tighten the screw

TAG INTERACTION WITH PC APPLICATION

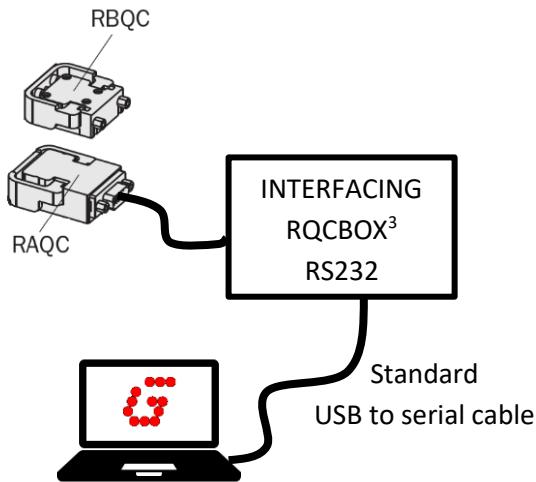

1. Download the application software¹ “RFID TOOLS AND MANUALS” from Gimatic’s website:
<http://www.gimatic.com/it/download/utility>
2. Install the software following the instructions included into the downloaded compressed file
3. If your computer/laptop doesn’t have a serial port, purchase a standard USB to serial converter cable from the market and install the relative drivers
4. Connect the RQCBOX to the power supply and to the RFID reader (RAQC/RAQCN) by means of the DSUB 15 pins connectors
5. Position the TAG (RBQC) close to the RAQC in the reading configuration
6. Connect the serial cable to the computer and check that your system correctly identifies the new hardware
7. Run the Gimatic’s RFID application
8. Select the correct serial port
9. Choose the reading or writing operation²

TOOL ID VISUALIZATION

The RQCBOX has 8 LED indicators on board that lights up accordingly with the ID stored into the TAG memory. Any LED is associated to a single digital output signal (DO).

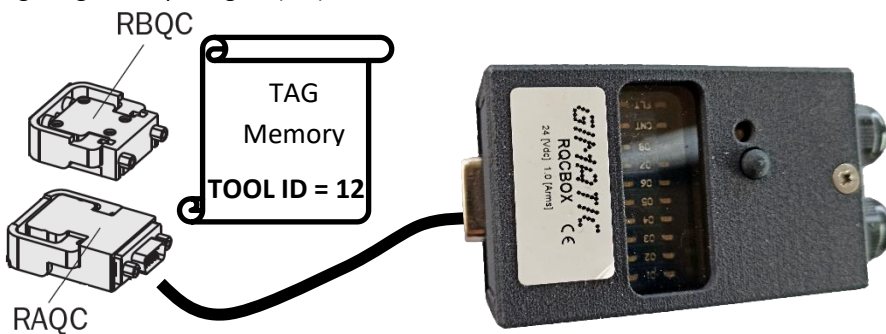

DB 15 connector (DO pin # only)							
DO_1	DO_2	DO_3	DO_4	DO_5	DO_6	DO_7	DO_8
0	0	1	1	0	0	0	0
LOW	LOW	HIGH	HIGH	LOW	LOW	LOW	LOW

TESTING OF CYCLES COUNTER

The RQCBOX is also equipped with a push button the user can press to simulate the acknowledgment signal that in normal working conditions is provided by a sensor box. The number of cycles executed by the TOOL will be increased by one per any single press down of the button.

¹The application software is available and tested for Windows 7,8,10® based system only.

²A password is required to correctly access the writing operations, please inquiry with Gimatic.